

Resistive Sensors Rotary Type (360° Rotation)

RDC80 Series

Hollow-shaft type that enables output covering the whole 360-degree angle due to adoption of the 2-phase output.

Magnetic Sensor

Piezo Sensor

Resistive Sensor

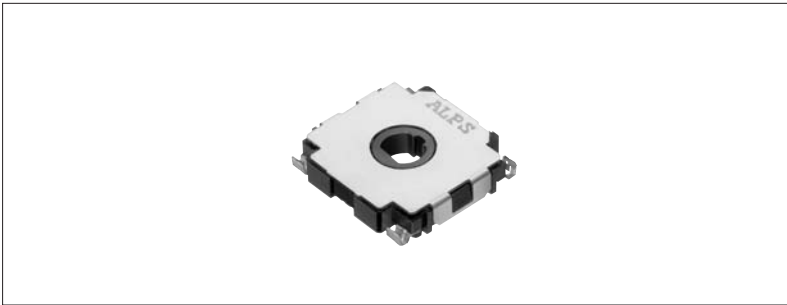

Features

- Reflow soldering available.
- Low-profile design 3mm in height.

Applications

- For controls on the onboard control panel in car etc.
- For control of home appliances
- For detection of rotation angles

Typical Specifications

Items	Specifications
Rating voltage	5V DC
Total resistance	10kΩ
Total resistance tolerance	±30%
Rotational angle	360° (without stopper)
Rotational torque	10mN·m max.
Durability	100,000cycles

Product list

Resistance taper (1-phase)	Linearity	Model No.	Minimum packing unit (pcs.)
B (linear) 100%/340°	±3%	RDC803001A	1,600

For other product specifications, see P.30

Dimensions

Unit:mm

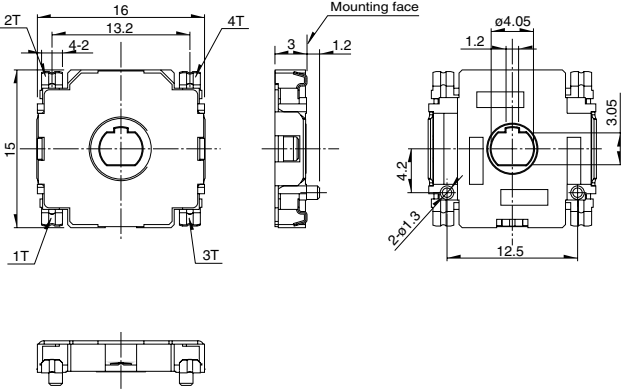
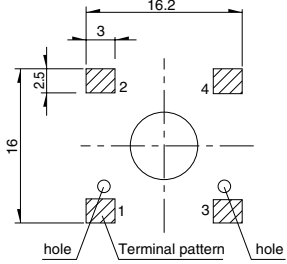
Photo	Style	PC board mounting hole dimensions
		

Magnetic Sensor

Piezo Sensor

Resistive Sensor

Circuit Diagram

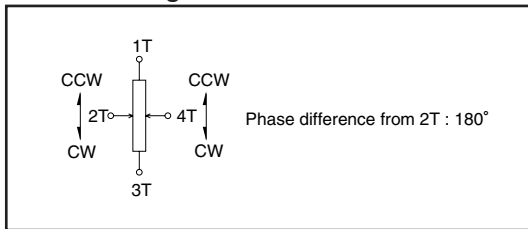

Taping Specifications

Unit:mm

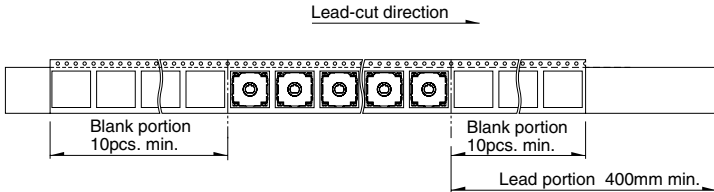
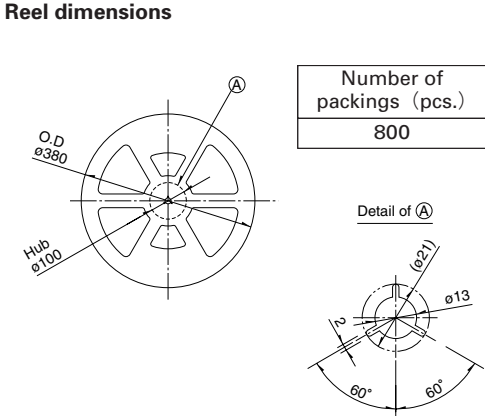
Dimension of embossed tape	Reel dimensions		
<p>Sealing conditions</p> 	 <table border="1" data-bbox="1222 1458 1414 1541"> <tr> <td>Number of packings (pcs.)</td> </tr> <tr> <td>800</td> </tr> </table>	Number of packings (pcs.)	800
Number of packings (pcs.)			
800			

Product Specifications

Item	Style	Rotary type			Linear type	
	Model	RDC40	RDC501/RDC502/ RDC503/RDC506	RDC80	RDC10	RD7
Operating temperature range		-30°C to +80°C	-40°C to +120°C		-30°C to +85°C	-40°C to +105°C
Electric performance	Total resistance tolerance	±30%				±20%
	Resistance taper	Linear				
	Rated voltage	5V DC				12V DC
	Max. operating voltage	18V DC	16V DC		5V DC	18V DC
	Linearity	±1%	±2%	±3%	±0.5%	±1%
Mechanical performance	Effective variable range	13rotations	320°	330° (1-phase) 360° (2-phase)	S (travel) -2mm	S (travel)
	Rotational angle	—	(Without stopper)		—	
	Rotational torque	2mN·m max.		10mN·m max.	—	
	Operating force	—			0.25N max.	2N less.
Durability	100,000cycles	●	—	●	—	●
	200,000cycles	—	—	—	●	—
	1,000,000cycles	—	●	—	—	—

Method for Regulating the Linearity

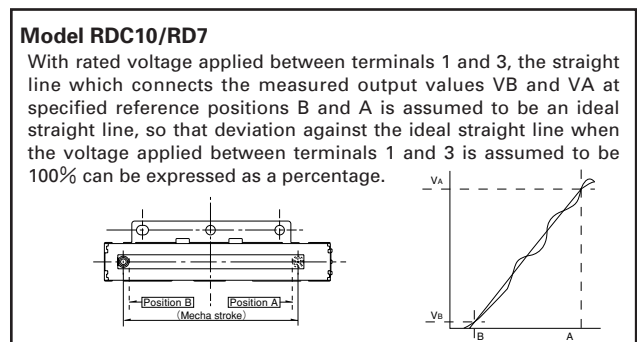
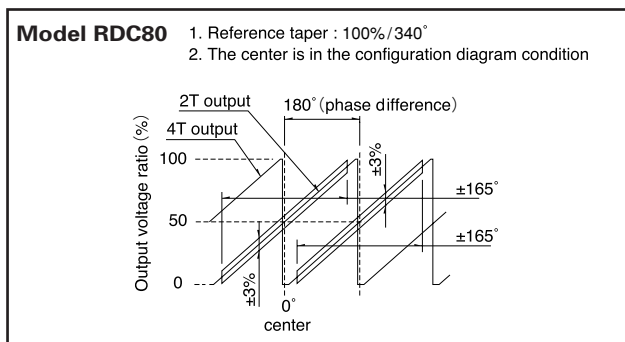
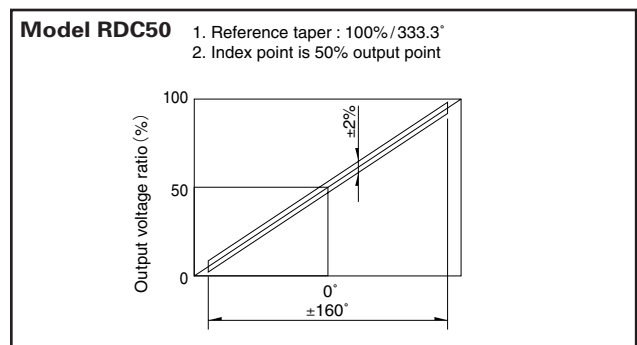
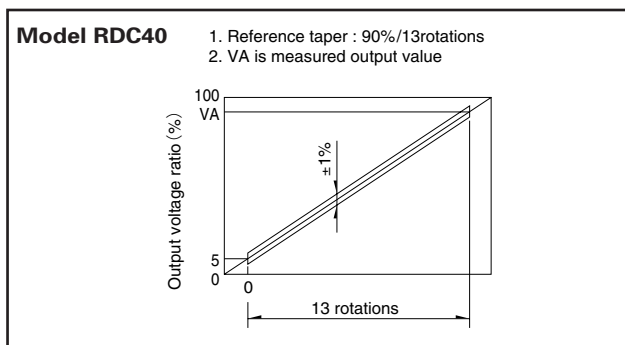

Soldering Conditions

Soldering Conditions

1. Recommended reflow conditions

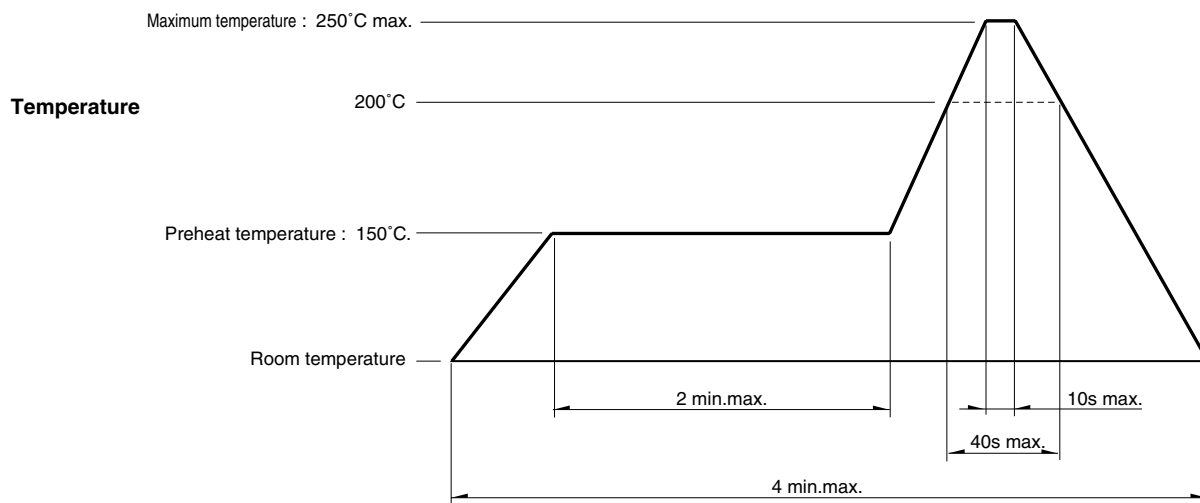

2. Cleaning Cleaning should not be attempted.
3. Type of solder to be used Use cream solder that contains 10 - 15 %wt flux.
4. Number of solder applications - apply solder only once

Notes

1. When using an infrared reflow oven, solder may not always be applied as intended. Be sure to use a hot air reflow oven or a type that uses infrared rays in combination with hot air.
2. The temperatures given above are the maximum temperatures at the terminals of the potentiometer when employing a hot air reflow method. The temperature of the PC board and the surface temperature of the potentiometer may vary greatly depending on the PC board material, its size and thickness. Ensure that the surface temperature of the potentiometer does not rise to 250°C or greater.
3. Conditions vary to some extent depending on the type of reflow bath used. Be sure to give due consideration to this prior to use.

Measurement and Test Methods

Analog Output Contact Type Sensor

[Total Resistance]

The total resistance, with the shaft (lever) placed at the end of terminal 1 or 3, shall be determined by measuring the resistance between the resistor terminals 1 and 3 unless otherwise specified.

[Rating Voltage]

The rating voltage corresponding to the rated power shall be determined by the following equation. When the resulting rated voltage exceeds the maximum operating voltage of a specific resistor, the maximum operating voltage shall be taken as the rated voltage.

$E = \sqrt{P \cdot R}$
E : Rated voltage (V)
P : Rated power (W)
R : Total nominal resistance (Ω)