



# E22-230T30D User Manual

SX1262 230MHz 1W LoRa wireless module



<b>DISCLAIMER AND COPYRIGHT NOTICE.....</b>	<b>3</b>
<b>CHAPTER 1 OVERVIEW.....</b>	<b>4</b>
1.1 PRODUCT INTRODUCTION.....	4
1.2 FEATURES.....	4
1.3 APPLICATION.....	5
<b>CHAPTER 2 PARAMETERS.....</b>	<b>5</b>
2.1 LIMITED PARAMETERS.....	5
2.2 WORKING PARAMETERS.....	5
<b>CHAPTER 3 MECHANICAL DIMENSIONS AND PIN DEFINITION.....</b>	<b>6</b>
<b>CHAPTER 4 RECOMMENDED WIRING DIAGRAM.....</b>	<b>8</b>
<b>CHAPTER 5 FUNCTION DETAILS.....</b>	<b>9</b>
5.1 FIXED POINT LAUNCH.....	9
5.2 BROADCAST TRANSMISSION.....	9
5.3 BROADCAST ADDRESS.....	10
5.4 LISTEN ADDRESS.....	10
5.5 MODULE RESET.....	10
5.6 DETAILED AUX.....	10
5.6.1 <i>Serial data output indication</i> .....	10
5.6.2 <i>Wireless transmission indication</i> .....	11
5.6.3 <i>Module is being configured</i> .....	11
5.6.4 <i>Precautions</i> .....	12
<b>CHAPTER 6 WORKING MODE.....</b>	<b>12</b>
6.1 MODE SWITCH.....	12
6.2 NORMAL MODE (MODE 0).....	13
6.3 WOR MODE (MODE 1).....	14
6.4 CONFIGURATION MODE (MODE 2).....	14
6.5 DEEP SLEEP MODE (MODE 3).....	14
<b>CHAPTER 7 REGISTER READ AND WRITE CONTROL.....</b>	<b>14</b>
7.1 INSTRUCTION FORMAT.....	14
7.2 REGISTER DESCRIPTION.....	15
7.3 FACTORY DEFAULT PARAMETERS.....	18

<b>CHAPTER 8 USE OF RELAY NETWORK MODE</b> .....	<b>19</b>
<b>CHAPTER 9 PC CONFIGURATION INSTRUCTIONS</b> .....	<b>20</b>
<b>CHAPTER 10 HARDWARE DESIGN</b> .....	<b>21</b>
<b>CHAPTER 11 FAQ</b> .....	<b>22</b>
11.1 THE TRANSMISSION DISTANCE IS NOT IDEAL.....	22
11.2 MODULE IS EASILY DAMAGED.....	22
11.3 BIT ERROR RATE TOO HIGH.....	23
<b>CHAPTER 12 WELDING OPERATION INSTRUCTIONS</b> .....	<b>23</b>
12.1 REFLOW TEMPERATURE.....	23
12.2 REFLOW SOLDERING CURVE.....	24
<b>CHAPTER 13 RELATED MODELS</b> .....	<b>24</b>
<b>CHAPTER 14 ANTENNA GUIDELINES</b> .....	<b>25</b>
14.1 ANTENNA RECOMMENDATION.....	25
<b>CHAPTER 15 BATCH PACKING METHOD</b> .....	<b>26</b>
<b>REVISE HISTORY</b> .....	<b>27</b>
<b>ABOUT US</b> .....	<b>27</b>

# Disclaimer and Copyright Notice

The information in this document, including the URL address for reference, is subject to change without notice. The document is provided "as is" without any guarantee responsibility, including any guarantee for marketability, suitability for a specific purpose, or non-infringement, and any guarantee for any proposal, specification or sample mentioned elsewhere. This document does not bear any responsibility, including the responsibility for infringement of any patent rights caused by the use of the information in this document. This document does not grant any license for the use of intellectual property rights in estoppel or other ways, whether express or implied.

The test data obtained in the article are all obtained by the Ebyte laboratory, and the actual results may vary slightly. We hereby declared that all brand names, trademarks and registered trademarks mentioned in this document are the property of their respective owners. The final interpretation right belongs to Chengdu Ebyte Electronic Technology Co., Ltd.

Notice :

Due to product version upgrades or other reasons, the contents of this manual may be changed. Ebyte Electronic Technology Co., Ltd. reserves the right to modify the contents of this manual without any hint or notice. This manual is only used as a guide. Chengdu Ebyte Electronic Technology Co., Ltd. makes every effort to provide accurate information in this manual. However, we do not guarantee that the contents of the manual are completely free of errors. All statements, information and suggestions in this manual do not constitute any express or implied guarantee.

# Chapter 1 Overview

## 1.1 Product Introduction

E22-230T30D is a new generation LoRa wireless module, based on SEMTECH SX1262 RF chip wireless serial module (UART), with a variety of transmission methods, working in the (220.125 ~ 236.125MHz) frequency band (default 230.125MHz), LoRa spread spectrum technology TTL level output, compatible with 3.3V and 5V IO port voltage.



E22-230T30D adopts the new generation LoRa spread spectrum technology, compared with the traditional SX1276 solution, SX1262 solution has longer transmission distance, faster speed, lower power consumption and smaller size; it supports wake-on-air, wireless configuration, carrier listening, automatic relay, communication key and other functions, supports sub-packet length setting, and can provide custom development services.

## 1.2 Features

- Develops new LoRa spread spectrum modulation technology based on SX1262, which brings longer communication distance and stronger anti-interference capability;
- Supports auto-relay networking, multi-level relay for ultra-long distance communication and multiple networks running simultaneously in the same area;
- Supports user-set communication key, and it cannot be read, which greatly improves the confidentiality of user data;
- Supports LBT function to listen to the channel environment noise before sending, which can greatly improve the communication success rate of the module in harsh environment;
- Supports RSSI signal strength indication function for evaluating signal quality, improving communication network and ranging;
- Supports wireless parameter configuration, sending command packets over the air to remotely configure or read wireless module parameters;
- Supports over-the-air wake-up, i.e., ultra-low power consumption function, for battery-powered application solutions;
- Supports fixed-point transmission, broadcast transmission, and channel monitoring;
- Supports deep hibernation, the power consumption of the whole unit in this mode is about 2uA;
- Supports 230MHz power band, with better penetration and bypass capability than 433MHz;
- Module built-in PA+LNA, communication distance up to 10km under ideal conditions;
- Parameters are saved at power-down, and the module will work according to the set parameters after re-powering;
- 
- Efficient watchdog design, once the abnormality occurs, the module will restart in automatically and can continue to work according to the previous parameter settings;
- Supports data transfer rates from 2.4k to 15.6kbps;

- Supports 3.3 to 5.5V power supply, and any power supply greater than 5V can ensure the best performance;
- Industrial standard design, supporting long time use at -40 to +85°C;
- Dual antenna optional (IPEX/stamp hole), easy for users to secondary development, easy to integrate.

### 1.3 Application

- Home security alarms and remote keyless entry;
- Smart home as well as industrial sensors, etc;
- Wireless alarm security systems;
- Building automation solutions;
- Wireless industrial grade remote controls;
- Healthcare products;
- Advanced Meter Reading Architecture (AMI);
- Automotive Industry Applications.

## Chapter 2 Parameters

### 2.1 Limited parameters

Main Param	Function		Notes
	Min	Max	
Power supply voltage (V)	0	5.5	Over 5.5V permanently burns out the module
blocking power (dBm)	-	10	The probability of burning at close range is small
Operating temperature (°C)	-40	+85	Industrial grade

### 2.2 Working parameters

Main Param	Function			Notes
	Min	Typical value	Max	
Working Voltage (V)	3.3	5.0	5.5	≥5.0V Guaranteed output power
Communication level (V)		3.3		There is a risk of burnout when using the 5V level
Working temperature (°C)	-40	-	+85	Industrial grade design
Working Frequency (MHz)	220.125	-	236.125	Support ISM band
功耗	Emission current (mA)		530	Instantaneous power consumption
	Receiving current (mA)		17	
	Sleep current (uA)		2	software shutdown

Maximum transmit power (dBm)	29.5	30.0	30.5	
Receive sensitivity (dBm)	-146	-147	-148	Air rate 2.4kbps
Air rate (bps)	2.4k	-	15.6k	User programming control

Main Param	Description	Notes
Distance	10km	Clear and open, antenna gain 5dBi, antenna height 2.5m, air rate 2.4kbps
Data length	240 Btye	Packets of 32/64/128/240 bytes can be sent by command
Cache capacity	1000 Btye	
Modulation	LoRa	Next generation LoRa modulation technology
Communication Interface	UART serial port	TTL Level
Packaging method	SMD	
Interface	Stamp hole	间距 2.54mm
Size	25*40.5mm	
RF Interface	IPEX/Stamp hole	Equivalent impedance is about 50Ω

## Chapter 3 Mechanical Dimensions and Pin Definition

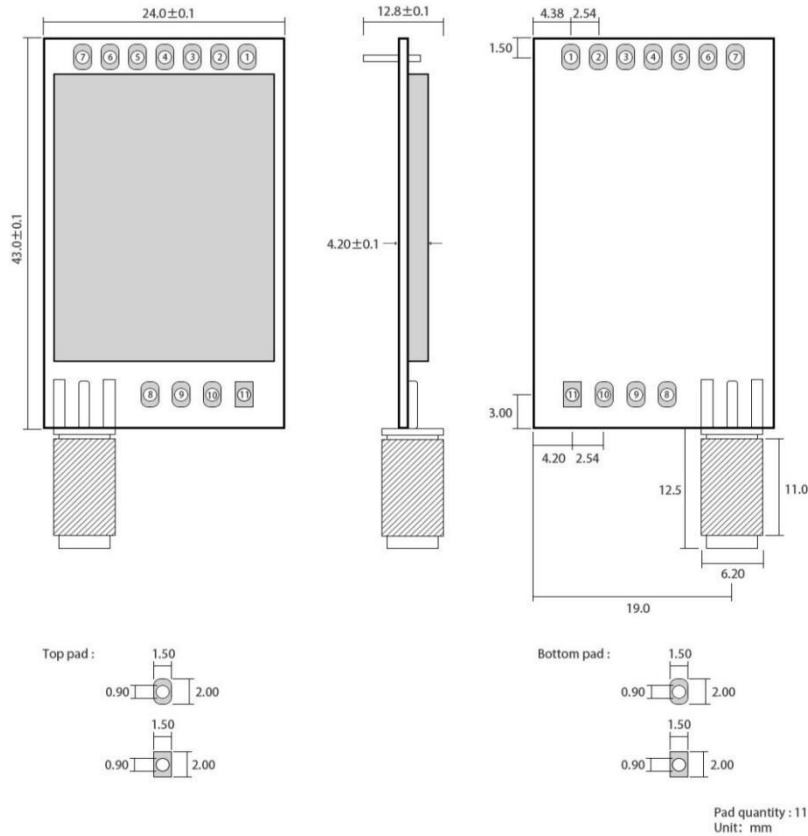
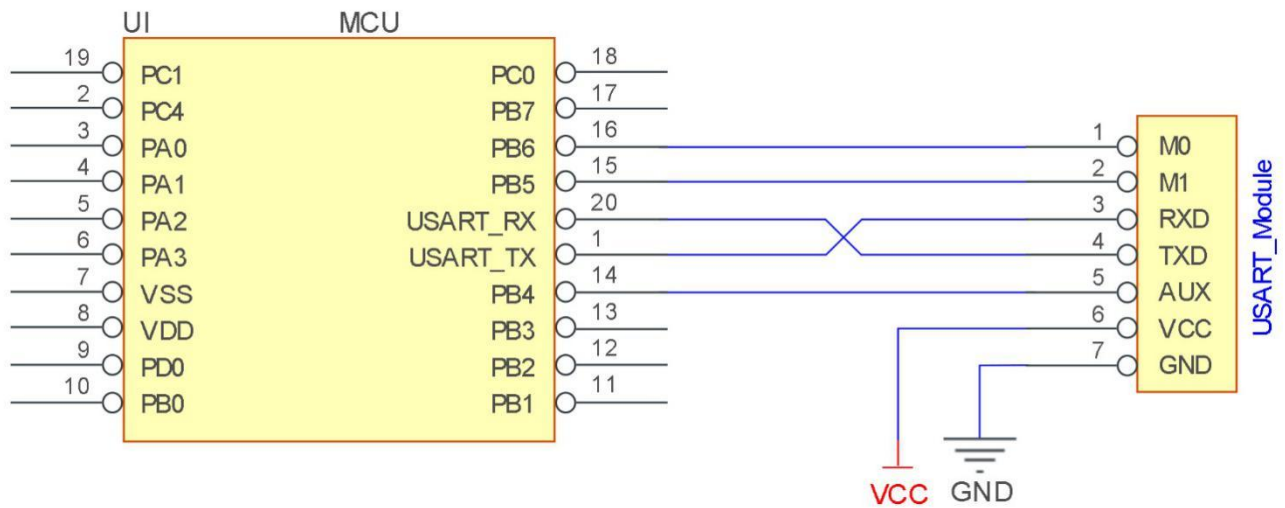

Figure 3-1 Mechanical dimensions and pin definition

Pin number	Pin name	Pin Orientation	pin usage
1	M0	Input (very weak pull-up)	Cooperate with M1 to determine the 4 working modes of the module (can not be suspended, if not used, it can be grounded)
2	M1	Input (very weak pull-up)	Cooperate with M0 to determine the 4 working modes of the module (can not be suspended, if not used, it can be grounded)
3	RXD	Input	TTL serial port input, connected to the external TXD output pin;
4	TXD	Output	TTL serial output, connected to external RXD input pin;
5	AUX	Output	Used to indicate the working state of the module; the user wakes up the external MCU, and outputs a low level during the power-on self-test initialization; (can be left floating)
6	VCC	Input	Module power supply positive reference, voltage range: 3.0 to 5.5V DC
7	GND	Input	Module Ground
8	Fixed hole	-	Fixed hole
9	Fixed hole	-	Fixed hole
10	Fixed hole	-	Fixed hole
11	Fixed hole	-	Fixed hole



## Chapter 4 Recommended Wiring Diagram



Item	A brief description of the connection between the module and the microcontroller (the above picture takes the STM8L microcontroller as an example)
1	The wireless serial port module is TTL level, please connect with TTL level MCU.
2	For some 5V microcontrollers, it may be necessary to add 4 to 10K pull-up resistors to the TXD and AUX pins of the module.

## Chapter 5 Function Details

### 5.1 Fixed point launch

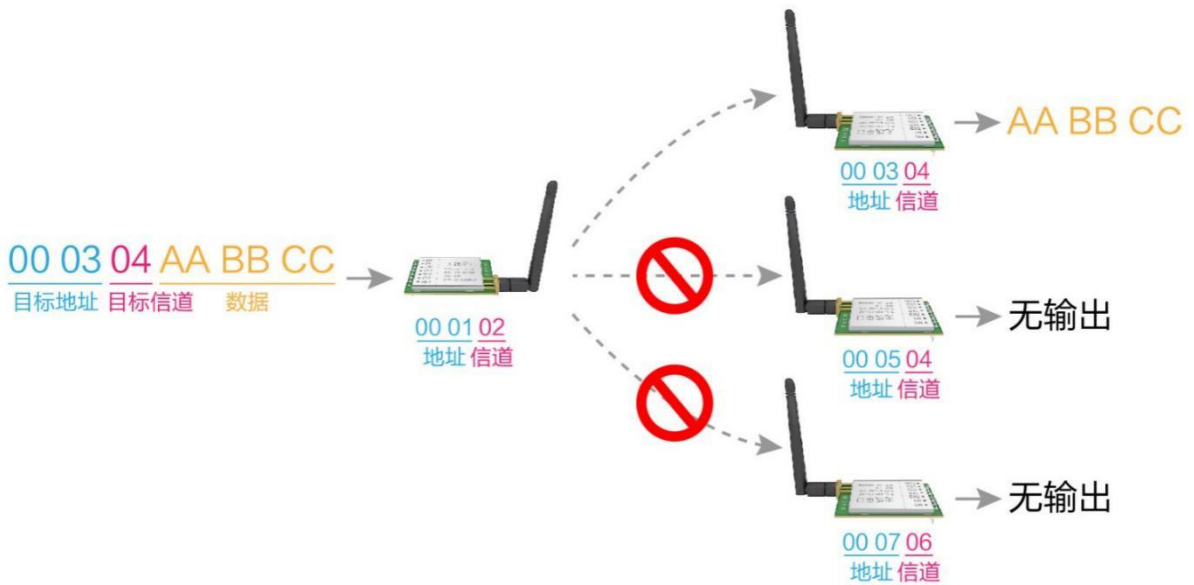

### 5.2 Broadcast transmission

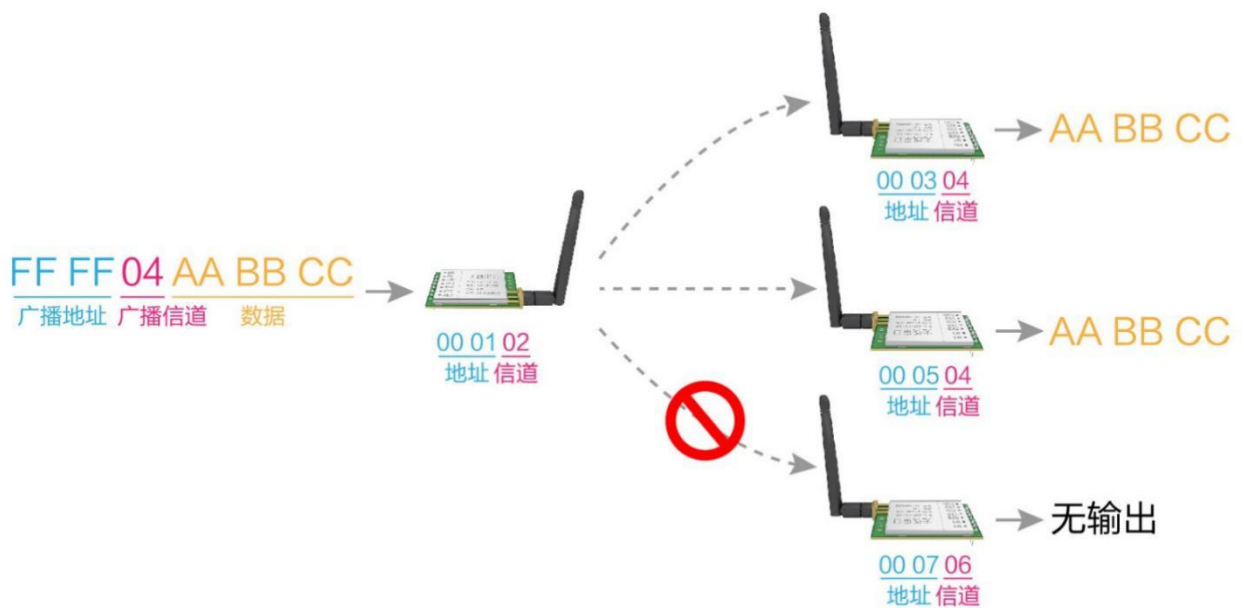

## 5.3 Broadcast address

- Example: Set the address of module A to 0xFFFF and the channel to 0x04.
- When module A is used as a transmitter (same mode, transparent transmission mode), all receiving modules under the 0x04 channel can receive data to achieve the purpose of broadcasting.

## 5.4 Listen address

- Example: Set the address of module A to 0xFFFF and the channel to 0x04.
- When module A is used as a receiver, it can receive all data under the 0x04 channel to achieve the purpose of monitoring.

## 5.5 Module reset

After the module is powered on, AUX will output a low level immediately, perform hardware self-check, and set the working mode according to user parameters; During this process, the AUX keeps the low level, and after the completion, the AUX outputs the high level, and starts to work normally according to the working mode composed of M1 and M0; Therefore, the user needs to wait for the rising edge of AUX as the starting point for the normal operation of the module.

## 5.6 Detailed AUX

- AUX is used for wireless transceiver buffer indication and self-check indication.
- It indicates whether the module has data that has not been transmitted wirelessly, or whether the received wireless data has not been sent through the serial port, or the module is in the process of initializing and self-checking.

### 5.6.1 Serial data output indication

- Used to wake up an external MCU from sleep;

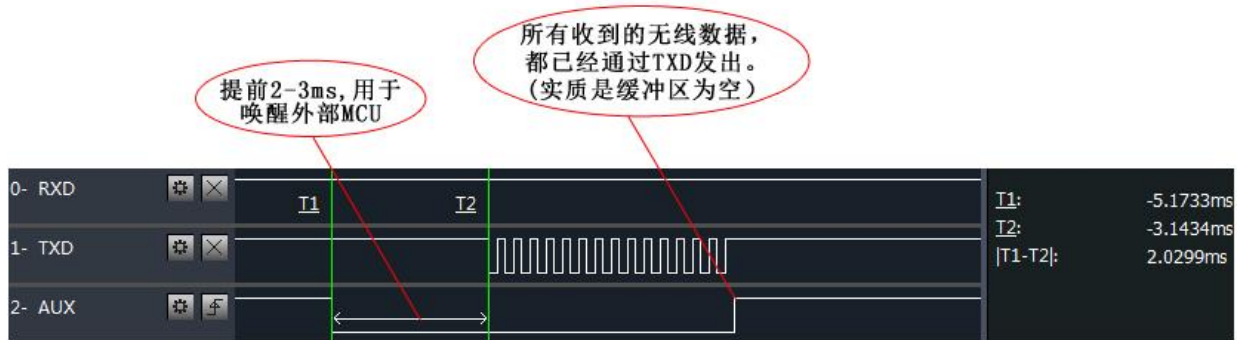

模块串口外发数据时，AUX引脚时序图

### 5.6.2 Wireless transmission indication

- Buffer empty: the data in the internal 1000 byte buffer, are written to the wireless chip (automatic packetization);

When AUX=1 the user initiates data less than 1000 bytes continuously, without overflow;

When AUX=0 buffer is not empty: the data in the internal 1000-byte buffer, not all written to the wireless chip and open to transmit, at this time the module may be waiting for the user data to end timeout, or is in the process of wireless sub-packet transmission.

**[Note]:** When AUX=1, it does not mean that all the serial data of the module has been emitted through wireless, or the last packet of data is being emitted.

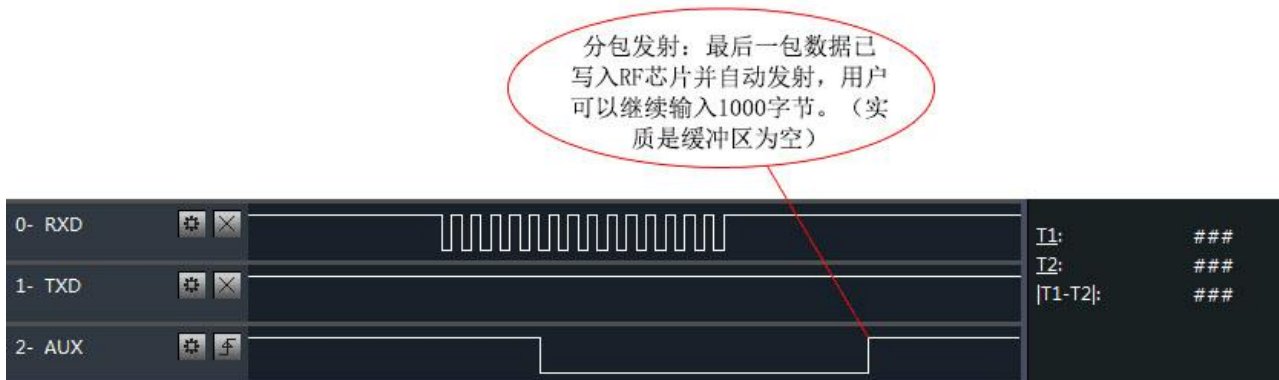

模块接收串口数据时，AUX引脚时序图

### 5.6.3 Module is being configured

- Only at reset and when exiting sleep mode;

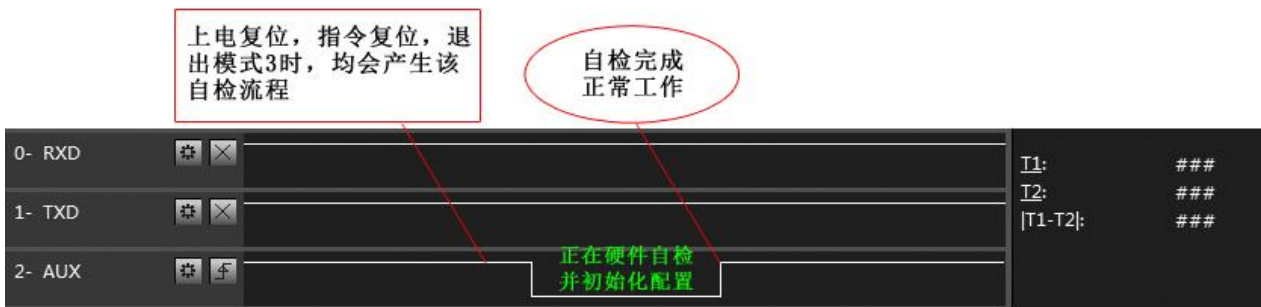

自检期间，AUX引脚时序图

### 5.6.4 Precautions

Item	AUX Notes
1	For the above functions 1 and 2, the output low level is given priority, that is, if any one of the output low level conditions is met, the AUX outputs the low level; When all low level conditions are not met, AUX outputs high level.
2	When AUX outputs a low level, it means that the module is busy, and the working mode detection will not be performed at this time; When the module AUX outputs a high level within 1ms, the mode switching will be completed.
3	After the user switches to the new working mode, at least 2ms after the rising edge of AUX, the module will actually enter this mode; If AUX is always high, then the mode switch will take effect immediately.
4	When the user enters other modes from mode 3 (sleep mode) or during the reset process, the module will reset the user parameters, during which AUX outputs a low level.
5	Due to the characteristics of LoRa modulation method, the information transmission delay is much longer than FSK, such as at 1.2kbps airspeed, 100 bytes transmission delay is about 1.5 seconds, it is recommended that customers should not carry out large data transmission at low airspeed, so as not to cause data loss due to data accumulation and cause communication abnormalities.

## Chapter 6 Working Mode

The module has four working modes, which are set by pins M1 and M0; the details are shown in the following table:

模式 (0-3)	M1	M0	Mode Introduction	Notes
0 Transmissio nmode	0	0	Open Serial port , wireless open, transparent transmission	Support special command over-the-air configuration
1 WORmode	0	1	Can be defined as WOR sender and WOR receiver	Support air wake-up
2 Configurati on mode	1	0	Users can access the registers through the serial port to control the working status of the module	
3 Deep sleep mode	1	1	Module goes to sleep	

### 6.1 Mode switch

Number	Notes

1	<ul style="list-style-type: none"> <li>● Users can combine M1 and M0 with high and low levels to determine the working mode of the module. The 2 GPIOs of the MCU can be used to control the mode switching;</li> <li>● After changing M1 and M0: If the module is idle, after 1ms, it can start to work according to the new mode;</li> <li>● If the module has serial port data that has not been transmitted wirelessly, the new working mode can only be entered after the transmission is completed;</li> <li>● If the module receives wireless data and sends out data through the serial port, it needs to be sent to the new working mode;</li> <li>● Therefore, the mode switching can only be effective when the AUX output is 1, otherwise the switching will be delayed.</li> </ul>
2	<ul style="list-style-type: none"> <li>● For example: if the user continuously inputs a large amount of data and switches modes at the same time, the mode switching operation is invalid at this time; the module will process all user data before performing the new mode detection;</li> <li>● So the general suggestion is: Detect the output state of the AUX pin, wait for 2ms after the output is high, and then switch.</li> </ul>
3	<ul style="list-style-type: none"> <li>● When the module is switched from other modes to sleep mode, if there is data that has not been processed;</li> <li>● The module can enter the sleep mode only after processing these data (including receiving and sending). This feature can be used for fast sleep to save power consumption; for example: the transmitter module works in mode 0, the user initiates serial port data "12345", and then does not need to wait for the AUX pin to be idle (high level), and can directly switch to sleep mode, Put the user's main MCU to sleep immediately, the module will automatically send all user data wirelessly, and automatically enter sleep within 1ms;</li> <li>● Thus, the working time of the MCU is saved and the power consumption is reduced.</li> </ul>
4	<ul style="list-style-type: none"> <li>● In the same way, this feature can be used for any mode switching. After the module processes the current mode event, it will automatically enter the new mode within 1ms; thus saving the user's work of querying AUX, and achieving the purpose of fast switching ;</li> <li>● For example, switching from the transmit mode to the receive mode; the user MCU can also go to sleep in advance before the mode switch, and use the external interrupt function to obtain the AUX change, so as to switch the mode.</li> </ul>
5	<ul style="list-style-type: none"> <li>● This operation mode is very flexible and efficient, and is completely designed according to the user's MCU operation convenience, and can reduce the workload of the entire system as much as possible, improve system efficiency, and reduce power consumption.</li> </ul>

## 6.2 Normal Mode (Mode 0)

Type	When M0 = 0, M1 = 0, the module works in mode 0
Transceiving	Users can input data through the serial port, and the module will start wireless transmission.
Receiving	The wireless receiving function of the module is turned on, and the wireless data will be output through the serial port TXD pin after receiving the wireless data.

### 6.3 WOR Mode (Mode 1)

Type	When M0 = 1, M1 = 0, the module works in mode 1
Transceiving	When defined as a transmitter, a wake-up code for a certain period of time will be automatically added before transmission
Receiving	Data can be received normally, and the receiving function is equivalent to mode 0

### 6.4 Configuration Mode (Mode 2)

Type	When M0 = 0, M1 = 1, the module works in mode 2
Transceiving	wireless transmission off
Receiving	wireless transmission off
Configuration	User can access registers to configure module operating status

### 6.5 Deep Sleep Mode (Mode 3)

Type	When M0 = 1, M1 = 1, the module works in mode 3
Transceiving	Unable to transmit wireless data.
Receiving	Unable to transmit wireless data.
Notes	When entering other modes from sleep mode, the module will reconfigure parameters. During the configuration process, AUX remains low; After completion, it outputs a high level, so it is recommended that the user detect the rising edge of AUX.

## Chapter 7 Register Read and Write Control

### 7.1 Instruction format

In configuration mode (mode 2: M1=1, M0=0), the list of supported commands is as follows (when setting, only 9600 and 8N1 formats are supported):

Number	Instruction format	详细说明
--------	--------------------	------

1	set register	<p>Instruction: C0+start address+length+parameter Response: C1+start address+length+parameters</p> <p>Example 1: Configure the channel as 0x09 Command Start address Length Parameter Send: C0 05 01 09 Return: C1 05 01 09</p> <p>Example 2: Configure module address (0x1234), network address (0x00), serial port (9600 8N1), air speed (1.2K) at the same time Send: C0 00 04 12 34 00 61 Return: C1 00 04 12 34 00 61</p>
2	read register	<p>Instruction: C1+start address+length Response: C1+start address+length+parameters</p> <p>Example 1: Read channel Command Start address Length Parameter Send: C1 05 01 Return: C1 05 01 09</p> <p>Example 2: Read module address, network address, serial port and airspeed at the same time Send: C1 00 04 Return: C1 00 04 12 34 00 61</p>
3	set temporary register	<p>Instruction: C2 + start address + length + parameters Response: C1 + start address + length + parameters</p> <p>Example 1: Configure the channel as 0x09 Command Start address Length Parameter Send: C2 05 01 09 Return: C1 05 01 09</p> <p>Example 2: Configure module address (0x1234), network address (0x00), serial port (9600 8N1), null speed (1.2K) at the same time Send: C2 00 04 12 34 00 61 Return: C1 00 04 12 34 00 61</p>
5	Wireless configuration	<p>Command: CF CF + General command Response: CF CF + general response</p> <p>Example 1: Wireless configuration channel is 0x09 Wireless Command Header Command Start Address Length Parameter Send: CF CF C0 05 01 09 Return: CF CF C1 05 01 09</p> <p>Example 2: Wireless simultaneously configure module address (0x1234), network address (0x00), serial port (9600 8N1), null speed (1.2K) Send: CF CF C0 00 04 12 34 00 61 Return: CF CF C1 00 04 12 34 00 61</p>
6	wrong format	<p>Format Error Response FF FF FF</p>

## 7.2 Register description

Item	Write /read	Name	Description	Notes
------	-------------	------	-------------	-------



00H	Write/ read	ADDH	ADDH (default 0)				Module address high byte and low byte; Note: When the module address is equal to FFFF, it can be used as a broadcast and listening address, that is, the module will not perform address filtering at this time.
01H	Write/ read	ADDL	ADDL (default0)				
02H	Write/ read	NETID	NETID (default0)				
03H	Write/ read	REG0	7	6	5	UART serial rate (bps)	For the two modules that communicate with each other, the serial port baud rate can be different, and the verification method can also be different;  When continuously transmitting large data packets, users need to consider the data blocking caused by the same baud rate, and may even be lost;  It is generally recommended that both sides of the communication have the same baud rate.
			0	0	0	Serial port baud rate is 1200	
			0	0	1	Serial port baud rate is 2400	
			0	1	0	Serial port baud rate is 4800	
			0	1	1	Serial port baud rate is 9600 (default)	
			1	0	0	Serial port baud rate is 19200	
			1	0	1	Serial port baud rate is 38400	
			1	1	0	Serial port baud rate is 57600	
			1	1	1	Serial port baud rate is 115200	
			4	3	Serial check digit		The serial port modes of both sides of the communication can be different;
			0	0	8N1 (default)		
			0	1	8O1		
			1	0	8E1		
			1	1	8N1 (equivalent 00)		
			2	1	0	Wireless air rate (bps)	The air speed of both parties must be the same;  The higher the air rate, the lower the delay and the shorter the transmission distance.
			0	0	0	Air rate2.4k	
			0	0	1	Air rate2.4k	
			0	1	0	Air rate2.4k	
			0	1	1	Air rate2.4k (default)	
1	0	0	空中速率 4.8k				
1	0	1	Air rate9.6k				
1	1	0	Air rate15.6k				
1	1	1	Air rate15.6k				
04H	Write/ read	REG1	7	6	Subcontracting settings		When the data sent by the user is less than the packet length, the serial output of the receiving end is presented as uninterrupted continuous output;
			0	0	240 bytes (default)		
			0	1	128 bytes		

			1	0	64 bytes		
			1	1	32bytes	If the data sent by the user is larger than the packet length, the serial port of the receiving end will be output in packets.	
			5	RSSI Ambient Noise Enable		Enable command (packet setting, transmit power as default parameters, configuration mode): C0 04 01 20;	
			0	disabled (default)		After it is enabled, the C0 C1 C2 C3 instruction can be sent in the transmission mode or the WOR transmission mode to read the register;	
			1	Enable		Register 0x00: Current ambient noise RSSI; Register 0X01: RSSI when data was last received (Current channel noise is: dBm = -(256 - RSSI)); Instruction format: C0 C1 C2 C3+start address+read length; Return: C1 + address + read length + read valid value; such as: send C0 C1 C2 C3 00 01 Return C1 00 01 RSSI (address can only start from 00)	
			4	3	2	Reserve	
			1	0	transmit power		
			0	0	30dBm (default)		
			0	1	27dBm		
			1	0	24dBm		
			1	1	21dBm		
							Power and current have a non-linear relationship, and the power supply efficiency is the highest at the maximum power;
							The current does not decrease proportionally as the power decreases.
05H	Write/ read	REG2	Channel Control (CH) 0-64respectively represent a total of 65 channels				Actual frequency = 220.125 + CH * 0.25M
06H	Write/ read	REG3	7	Enable RSSI bytes		When enabled, the module receives wireless data and outputs it through the serial port TXD, followed by an RSSI strength byte.	
			0	disabled (default)			
			1	Enable			
			6	transfer method		For fixed-point transmission, the module identifies the money three bytes of the serial data as: address high + address low + channel, and uses them as the wireless transmitting target.	
			0	transparent transmission (default)			
			1	fixed point transmission			
			5	Relay function		(a) When the relay function is enabled, the module will initiate a forwarding if the destination address is not the module itself;	
			0	Disable relay function (default)			
			1	Enable relay function		To prevent data backhaul, it is recommended to use with fixed-point mode; i.e., the destination address and the source address are different.	
			4	LBT Enable		After enabling, the wireless data will be monitored before transmission, which can	
0	disabled (default)						

			1	enable			avoid interference to a certain extent, but may cause data delay;  The maximum stay time of LBT is 2 seconds. When it reaches two seconds, it will be issued forcibly.
			3	WOR Mode Transceiver Control			Valid only for mode 1;
			0	WOR receiver (default) Working in WOR monitor mode, the monitor cycle is shown below (WOR cycle), which can save a lot of power consumption.			(a) After the WOR receiver receives the wireless data and outputs it through the serial port, it will wait 1000ms before entering WOR again, during which time the user can enter the serial data and return it through the wireless;
			1	WOR transmitter The transceiver is turned on, and a wake-up code for a certain period of time is added when transmitting data.			each serial byte will be refreshed for 1000ms time;  The user must initiate the first byte within 1000ms.
			2	1	0	WORcycle	Valid only for mode 1;
			0	0	0	500ms	
			0	0	1	1000ms	cycle time $T = (1+WOR) * 500ms$ , maximum 4000ms, minimum 500ms;
			0	1	0	1500ms	
			0	1	1	2000ms	the longer the WOR listening interval cycle time, the lower the average power consumption, but the greater the data delay;
			1	0	0	2500ms	
			1	0	1	3000ms	
			1	1	0	3500ms	Sending and receiving sides must be consistent (very important)
			1	1	1	4000ms	
07H	Write	CRYPT_H	Key high byte (default 0)				Write-only, with reads returning 0; Used for encryption to avoid interception of over-the-air wireless data by similar modules;
08H	Write	CRYPT_L	Key Low byte (default 0)				These two bytes will be used internally by the module as calculation factors to transform the over-the-air radio signal for encryption.
80H~86H	Read	PID	Product information 7 bytes				Product information 7 bytes

### 7.3 Factory default parameters

Mode	Factory default parameter value: C0 00 00 62 00 28						
Module number	Frequency	Address	Channel	Air rate	Baud rate	Serial format	transmit power
E22-230T30D	230.125MHz	0x0000	0x28	2.4kbps	9600	8N1	30dbm

## Chapter 8 Use of Relay Network Mode

序号	Relay Mode Description
1	After setting the relay mode through the configuration mode, switch to the general mode, and the relay starts to work.
2	In relay mode, ADDH and ADDL are no longer used as module addresses, but correspond to NETID forwarding pairing respectively. If one network is received, it will be forwarded to the other network; The network ID of the repeater itself is invalid.
3	In relay mode, the relay module cannot send and receive data, and cannot perform low-power operation.
4	When the user enters other modes from mode 3 (sleep mode) or during the reset process, the module will reset the user parameters, during which AUX outputs a low level.

Trunking rules description:

- 1、Forwarding rules, trunking can forward data in both directions between two NETIDs.
- 2、In trunk mode, ADDH/ADDL is no longer used as a module address and is forwarded as a NETID pair.

As shown in the figure:

### ①First-level relay

"Node 1" NETID is 08.

"Node 2" NETID is 33.

The ADDH\ADDL of relay 1 are 08 and 33 respectively.

So the signal sent by node 1 (08) can be forwarded to node 2 (33)

At the same time, the addresses of node 1 and node 2 are the same, so the data sent by node 1 can be received by node 2.

### ②Secondary relay

The ADDH\ADDL of relay 2 are 33 and 05 respectively.

So relay 2 can forward relay 1's data to network NETID: 05.

Therefore, node 3 and node 4 can receive the data of node 1. Node 4 outputs data normally, and node 3 and node 1 have different addresses, so no data is output.

### ③Two-way relay

As shown in the configuration: the data sent by node 1 can be received by nodes 2 and 4, and the data sent by nodes 2 and 4 can also be received by node

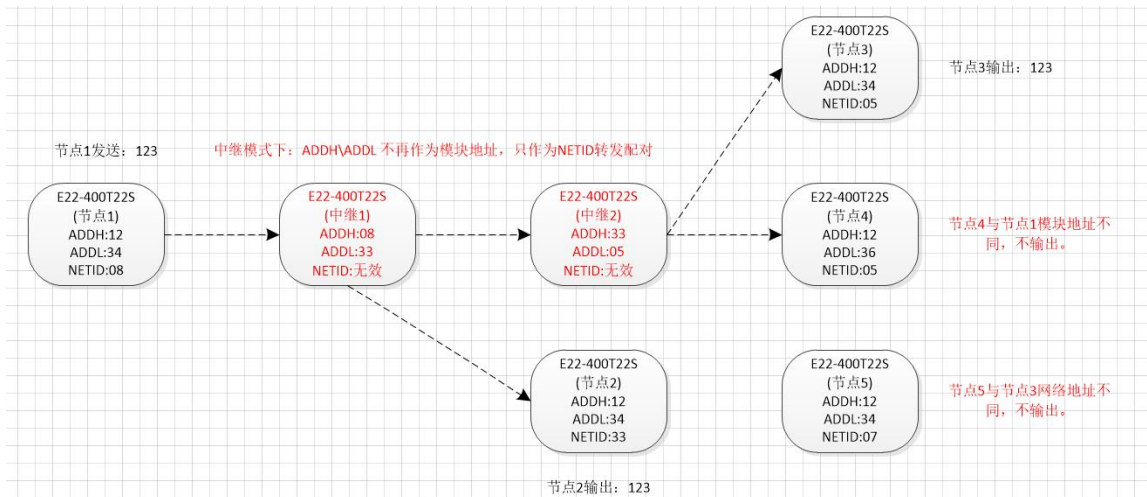

## Chapter 9 PC Configuration Instructions

- The following picture shows the E22-230T30D configuration host computer display interface, the user can switch to command mode through M0 and M1, and quickly configure and read parameters on the host computer.



- In the configuration of the host computer, the module address, frequency channel, network ID, and key are all displayed in decimal; the value range of each parameter is as follows:

Network address: 0~65535

Frequency channel: 0~83

Network ID: 0~255

Key: 0~65535

When using the host computer to configure the relay mode, users need to pay special attention, because in the host computer, each parameter is displayed in decimal mode, so the module address and network ID need to be converted into decimal when filling in;

If the network ID input by transmitter A is 02, and the network ID input by receiver B is 10, then when relay

terminal R sets the module address, convert the hexadecimal value 0X020A to decimal value 522 and fill in as relay terminal R the module address;

That is, the module address value that needs to be filled in by the relay terminal R at this time is 522.

## Chapter 10 Hardware Design

- It is recommended to use a DC regulated power supply to supply power to the module, the power supply ripple coefficient should be as small as possible, and the module should be grounded reliably;
- Please pay attention to the correct connection of the positive and negative poles of the power supply. If the reverse connection will directly cause permanent damage to the module, it is recommended to design and add an anti-reverse connection circuit.
- Please check the power supply to ensure that it is between the recommended power supply voltages. If it exceeds the maximum value, the module will be permanently damaged;
- Please check the stability of the power supply, the voltage should not fluctuate greatly and frequently;
- When designing the power supply circuit for the module, it is often recommended to reserve more than 30% of the margin, so that the whole machine can work stably for a long time;
- The module should be kept as far away as possible from the power supply, transformer, high-frequency wiring and other parts with large electromagnetic interference;
- High-frequency digital traces, high-frequency analog traces, and power traces must avoid the underside of the module. If it is necessary to pass under the module, assuming that the module is soldered on the Top Layer, ground copper (all copper) is placed on the Top Layer of the contact part of the module. And well grounded), it must be close to the digital part of the module and routed on the Bottom Layer;
- Assuming that the module is soldered or placed on the Top Layer, it is also wrong to arbitrarily route wires on the Bottom Layer or other layers, which will affect the stray and receiving sensitivity of the module to varying degrees;
- Assuming that there are devices with large electromagnetic interference around the module, it will greatly affect the performance of the module. It is recommended to stay away from the module according to the intensity of the interference. If the situation allows, appropriate isolation and shielding can be done.;
- Assuming that there are traces with large electromagnetic interference around the module (high-frequency digital, high-frequency analog, power traces), the performance of the module will also be greatly affected. It is recommended to stay away from the module according to the intensity of the interference. Proper isolation and shielding;
- If the communication line uses a 5V level, a 1k-5.1k resistor must be connected in series (not recommended, there is still a risk of damage);
- The antenna installation structure has a great influence on the performance of the module, and it is necessary to ensure that the antenna is exposed and preferably vertically upward;
- When the module is installed inside the case, a high-quality antenna extension cable can be used to extend the antenna to the outside of the case;

The antenna must not be installed inside the metal shell, which will greatly reduce the transmission distance.

## Chapter 11 FAQ

### 11.1 The transmission distance is not ideal

- When there is a linear communication barrier, the communication distance will be attenuated accordingly;
- Temperature, humidity, co-channel interference, which can lead to increased communication packet loss;
- The ground absorbs and reflects radio waves and is less effective for testing close to the ground;
- Seawater has a very strong ability to absorb radio waves, so the seaside test is poor;
- Antenna near a metal object, or placed in a metal case, the signal attenuation will be very serious;
- Wrong power register setting, too high air rate setting (the higher the air rate, the closer the distance);
- Power supply low voltage at room temperature is lower than the recommended value, the lower the voltage, the smaller the power generation;
- Use antenna and module match the degree of poor or antenna itself quality problems.

### 11.2 Module is easily damaged

- Please check the power supply to ensure that it is within the recommended power supply voltage. If it exceeds the maximum value, the module will be permanently damaged.;
- Please check the stability of the power supply, the voltage should not fluctuate greatly and frequently;
- Please ensure anti-static operation during installation and use, the electrostatic sensitivity of high-frequency components;
- Please ensure that the humidity during installation and use should not be too high. Some components are humidity-sensitive components.;
- If there is no special requirement, it is not recommended to use it at too high or too low temperature.

## 11.3 Bit error rate too high

- There is co-frequency signal interference nearby, stay away from the interference source or modify the frequency and channel to avoid interference;
- If the power supply is not ideal, it may also cause garbled characters. Be sure to ensure the reliability of the power supply. ;
- Poor quality or too long extension cables and feeders will also cause high bit error rates.

# Chapter 12 Welding Operation Instructions

## 12.1 Reflow temperature

Profile Feature	Curve feature	Sn-Pb Assembly	Pb-Free Assembly
Solder Paste	solder paste	Sn63/Pb37	Sn96.5/Ag3/Cu0.5
Preheat Temperature min (T <sub>min</sub> )	Minimum preheat temperature	100°C	150°C
Preheat temperature max (T <sub>max</sub> )	maximum preheat temperature	150°C	200°C
Preheat Time (T <sub>min</sub> to T <sub>max</sub> )(ts)	maximum preheat temperature	60-120 sec	60-120 sec
Average ramp-up rate(T <sub>max</sub> to T <sub>p</sub> )	Average rate of ascent	3°C/second max	3°C/second max
Liquidous Temperature (TL)	liquidus temperature	183°C	217°C
Time (tL) Maintained Above (TL)	time above liquidus	60-90 sec	30-90 sec
Peak temperature (T <sub>p</sub> )	Peak temperature	220-235°C	230-250°C
Average ramp-down rate (T <sub>p</sub> to T <sub>max</sub> )	Average rate of descent	6°C/second max	6°C/second max
Time 25°C to peak temperature	Time from 25° C to peak temperature	6 minutes max	8 minutes max



## 12.2 Reflow Soldering Curve

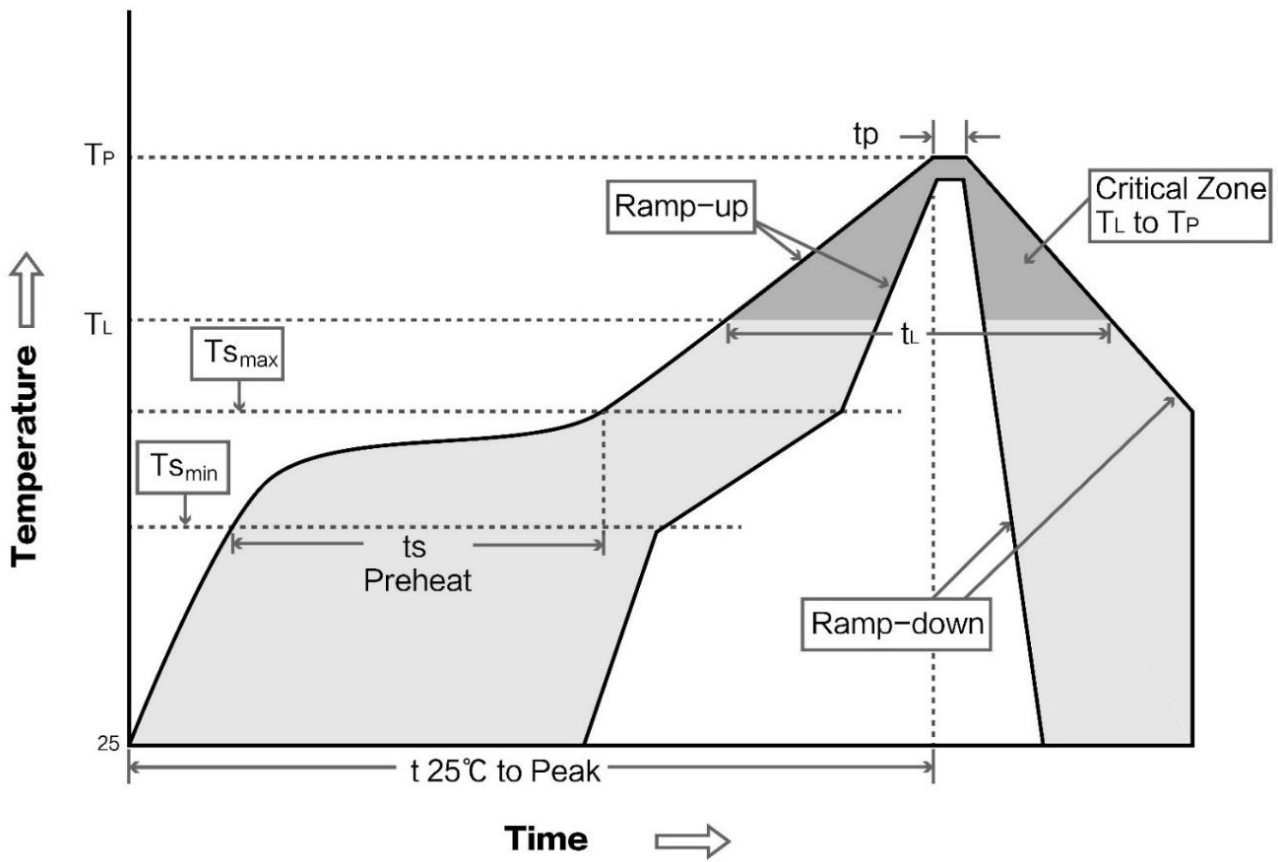

## Chapter 13 Related Models

Product	IC	Frequency Hz	Power dBm	Distance km	Packaging	Size mm	Communication interface
<a href="#">E22-230T22S</a>	SX1262	230M	22	5	SMD	16*26	TTL
<a href="#">E22-230T30D</a>	SX1262	230M	30	10	SMD	20*40.5	TTL
<a href="#">E22-400T22S</a>	SX1268	433/470M	22	5	SMD	16*26	TTL
<a href="#">E22-400T30S</a>	SX1268	433/470M	30	10	SMD	20*40.5	TTL
<a href="#">E22-900T22S</a>	SX1262	868/915M	22	5	SMD	16*26	TTL
<a href="#">E22-900T30S</a>	SX1262	868/915M	30	10	SMD	20*40.5	TTL
<a href="#">E22-400M22S</a>	SX1268	433/470M	22	7	SMD	14*20	SPI
<a href="#">E22-400M30S</a>	SX1268	433/470M	30	12	SMD	24*38.5	SPI
<a href="#">E22-900M22S</a>	SX1262	868/915M	22	7	SMD	14*20	SPI
<a href="#">E22-900M30S</a>	SX1262	868/915M	30	12	SMD	24*38.5	SPI

## Chapter 14 Antenna Guidelines

### 14.1 Antenna recommendation

Antennas play an important role in the communication process, and often inferior antennas will have a great impact on the communication system. Therefore, our company recommends some antennas as antennas with excellent performance and reasonable price for our wireless modules.

Product	Type	Frequency Hz	Interface	Gain dBi	Height mm	Feeder cm	Function
<a href="#">TX230-JK-11</a>	Rubber antenna	230M	SMA-J	2.5	110	-	Bendable glue stick, omni-directional antenna
<a href="#">TX230-JK-20</a>	Rubber antenna	230M	SMA-J	3.0	210	-	Bendable glue stick, omni-directional antenna
<a href="#">TX230-XP-200</a>	Suker antenna	230M	SMA-J	4.0	350	200	Neutral suction cup antenna with low loss
<a href="#">TX230-XP-300</a>	Suker antenna	230M	SMA-J	5.5	745	300	Large suction cup antenna, high gain

## Chapter 15 batch packing method

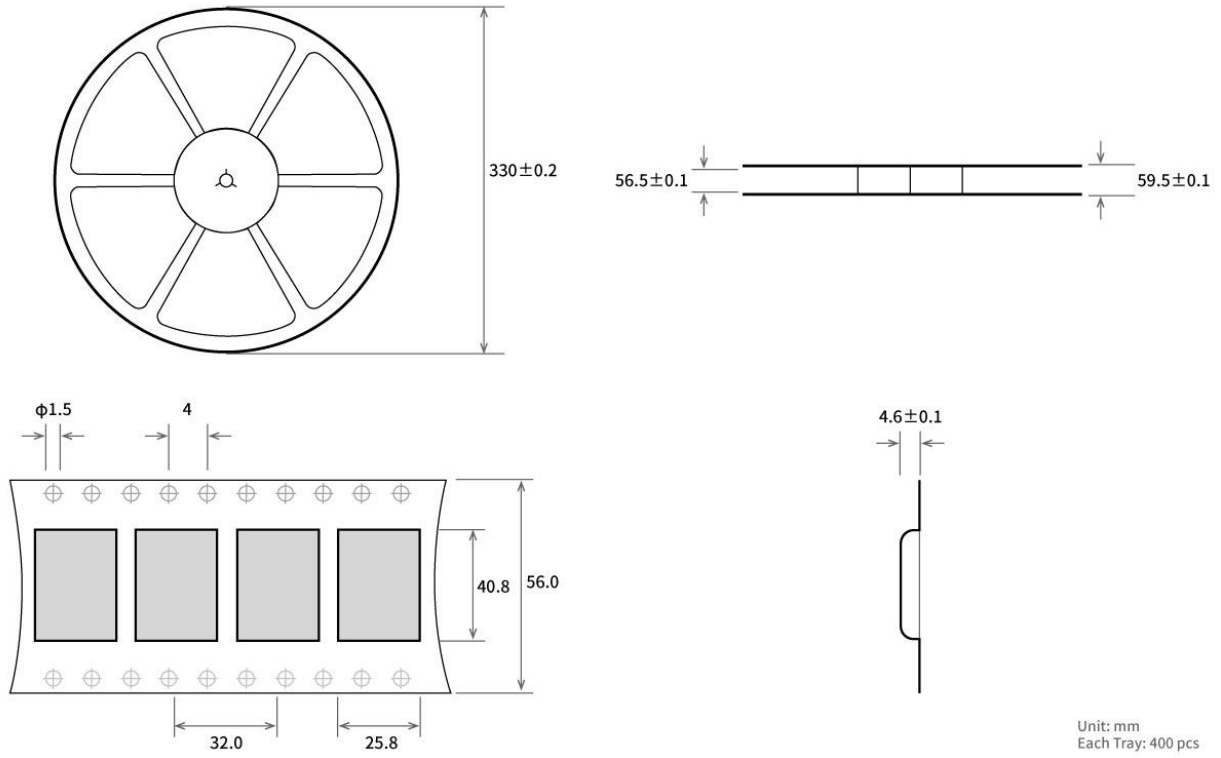

## Revise History

Version	Revision date	Description	Issued by
1.0	2018-01-08	Initial Version	huaa
1.1	2018-04-16	Content Updates	huaa
1.2	2018-05-24	Name Change	Huaa
1.3	2018-07-20	Model split	Huaa
1.4	2018-10-23	Content Updates	Ray
1.5	2019-04-03	Content Updates	Ray
1.6	2020-04-15	Modify error	du
1.8	2020-06-10	14.1 Antenna frequency band from 433 to 230	du
1.9	2020-11-26	Modify error	Linson
2.0	2023-4-6	Modify error	Yan

## About Us

**Sales Hotline:** 4000-330-990

**Company Tel:** 028-61399028

**Technical support:** support@cdebyte.com

**Official website:** <https://www.cdebyte.com/>

**Company Address:** Building B5, No. 199, West District Avenue, High-tech West District, Chengdu City, Sichuan Province

