



E22-900T33S Product Specification

SX1262 868 / 915MHz 2W LoRa Wireless module



DISCLAIMER AND COPYRIGHT NOTICE	2
1 PRODUCT OVERVIEW	3
1.1 PRODUCT INTRODUCTION	3
1.2 FEATURE FUNCTION	3
1.3 APPLICATION SCENARIO	4
2 SPECIFICATIONS	4
2.1 LIMIT PARAMETER	4
2.2 WORKING PARAMETERS	4
3 MECHANICAL DIMENSIONS AND PIN DEFINITION	5
4 RECOMMENDED CONNECTION DIAGRAM	6
5 DETAILED FUNCTION EXPLANATION	7
5.1 FIXED - POINT LAUNCH	7
5.2 BROADCAST TRANSMISSION	8
5.3 BROADCAST	8
5.4 LISTENING	8
5.5 MODULE	8
5.6 DETAILED EXPLANATION OF AUX	9

5.6.1 Serial port data output indication 9

Disclaimer and Copyright Notice

Information in this document, including URL references, is subject to change without notice. The documentation is provided "as is" without any warranty of any kind, including any warranties of merchantability, fitness for a particular purpose, or non-infringement, and any warranties mentioned elsewhere in any proposal, specification, or sample. This document disclaims any responsibility, including liability for infringement of any patent rights arising out of the use of the information in this document. No license, express or implied, to any intellectual property right is hereby granted by this document, whether by estoppel or otherwise.

The test data obtained in this article are all obtained from Ebyte laboratory tests, and the actual results may be slightly different.

All trade names, trademarks and registered trademarks mentioned herein are the property of their respective owners and are hereby declared.

The final interpretation right belongs to Chengdu Ebyte Electronic Technology Co., Ltd.

Note :

Due to product version upgrades or other reasons, the contents of this manual may change. Ebyte Electronic Technology Co., Ltd. reserves the right to modify the contents of this manual without any notice or prompt. This manual is only used as a guide. Chengdu Ebyte Electronic Technology Co., Ltd. makes every effort to provide accurate information in this manual, but Chengdu Ebyte Electronic Technology Co., Ltd. does not guarantee that the content of the manual is completely error-free. All statements in this manual, information and advice do not constitute any express or implied warranty.

1 Product Overview

1.1 product introduction

E22-900T33S is a new generation of Lo Ra wireless module. It is a wireless serial module (UART) based on SX1262 RF chip. Spread spectrum technology, TTL level output, compatible with 3.3V and 5V IO port voltage.

E22-900T33S adopts a new generation of LoRa spread spectrum technology. Compared with the traditional SX127 6 solution, the SX1262 solution has a longer transmission distance, faster speed, lower power consumption, and smaller size; it supports air wake-up, wireless configuration, and carrier sense. , automatic relay, communication key and other functions, support subpackage length setting, and can provide customized development services.



1.2 Features

- Based on SX1262 , a new Lo Ra spread spectrum modulation technology is developed , which brings longer communication distance and stronger anti-interference ability ;
- Support automatic relay networking, multi-level relay is suitable for ultra-long-distance communication , and multiple networks run simultaneously in the same area ;
- Support users to set the communication key by themselves, and it cannot be read, which greatly improves the confidentiality of user data;
- Support LBT function , monitor the channel environment noise before sending, which can greatly improve the communication success rate of the module in harsh environments ;
- Support RSSI signal strength indication function , used to evaluate signal quality, improve communication network, distance measurement;
- Support wireless parameter configuration, send command packets wirelessly, remotely configure or read wireless module parameters ;
- Support air wake-up, that is, ultra-low power consumption function, suitable for battery-powered applications;
- Support fixed-point transmission, broadcast transmission, channel monitoring;
- Support deep sleep, the power consumption of the whole machine is about 4uA in this mode ;
- Support global license-free ISM 868/915 MHz frequency band ;
- The module has built-in PA + LNA , and the communication distance can reach 16 km under ideal conditions;
- The parameters are saved after power-off , and the module will work according to the set parameters after power-on ;
- Efficient watchdog design, once an exception occurs, the module will automatically restart and continue to work according to the previous parameter settings ;
- Support data transmission rate of 2.4k ~ 62.5k bps ;
- Support 3.3 ~ 5.5V power supply, power supply greater than 5V can guarantee the best performance;
- Industrial-grade standard design, supporting long-term use at -40 ~ + 85 °C;
- Dual antennas are optional (IPEX/ stamp hole) , which is convenient for secondary development and integration.

1.3 Application Scenario

- Home security alarm and remote keyless entry;
- Smart home and industrial sensors, etc.;
- Wireless alarm security system ;
- Building automation solutions;
- Wireless industrial grade remote control;
- healthcare products;
- Advanced Meter Reading Infrastructure (AMI);
- Automotive industry applications.

2 Specifications

2.1 Limit parameter

The main parameters	performance		Remark
	minimum value	maximum value	
Power supply voltage (V)	3.3	5.5	Exceeding 5.5V may permanently burn the module
Blocking power (dBm)	-	10	Less chance of burning when used at close range
Working temperature (°C)	-40	+85 _	industrial grade

2.2 Working parameters

The main parameters	performance			Remark	
	minimum value	typical value	maximum value		
Working voltage (V)	3.3	5.0	5.5	≥5.0V guaranteed output power	
Communication level (V)		3.3 _		when using a 5V level	
Working temperature (°C)	-40	-	+85 _	industrial design	
Working frequency band (MHz)	850.125	-	930.125 _	Support ISM frequency band	
power consumption	Emission current (mA)	-	610	-	Instantaneous power consumption @33 dBm
	Receive current (mA)	-	17	-	-
	Sleep current (uA)	-	4	-	software shutdown

Maximum transmit power (dBm)	32	33	34	-
Receiving sensitivity (dBm)	-123	-124	-125	Air rate 2.4 kbps
Air rate (bps)	2.4k _	2.4k	62.5k	User Programmable Control
Reference distance	16km _ _			Clear sky, antenna gain 5dBi, antenna height 2.5 meters, air rate 2.4kbps
launch length	2 4 0 Byte			4 0 bytes can be sent by command setting
cache capacity	1000 Byte			-
Modulation	LoRa			A new generation of Lo R a modulation technology
Communication Interface	UART serial port			T TL level
Encapsulation	SMD _			-
Interface	stamp hole			Stamp hole, pitch 2.54mm
Dimensions	25*40.5mm			-
RF interface	IPEX/stamp hole			Equivalent impedance about 50 Ω

3 Mechanical Dimensions and Pin Definitions

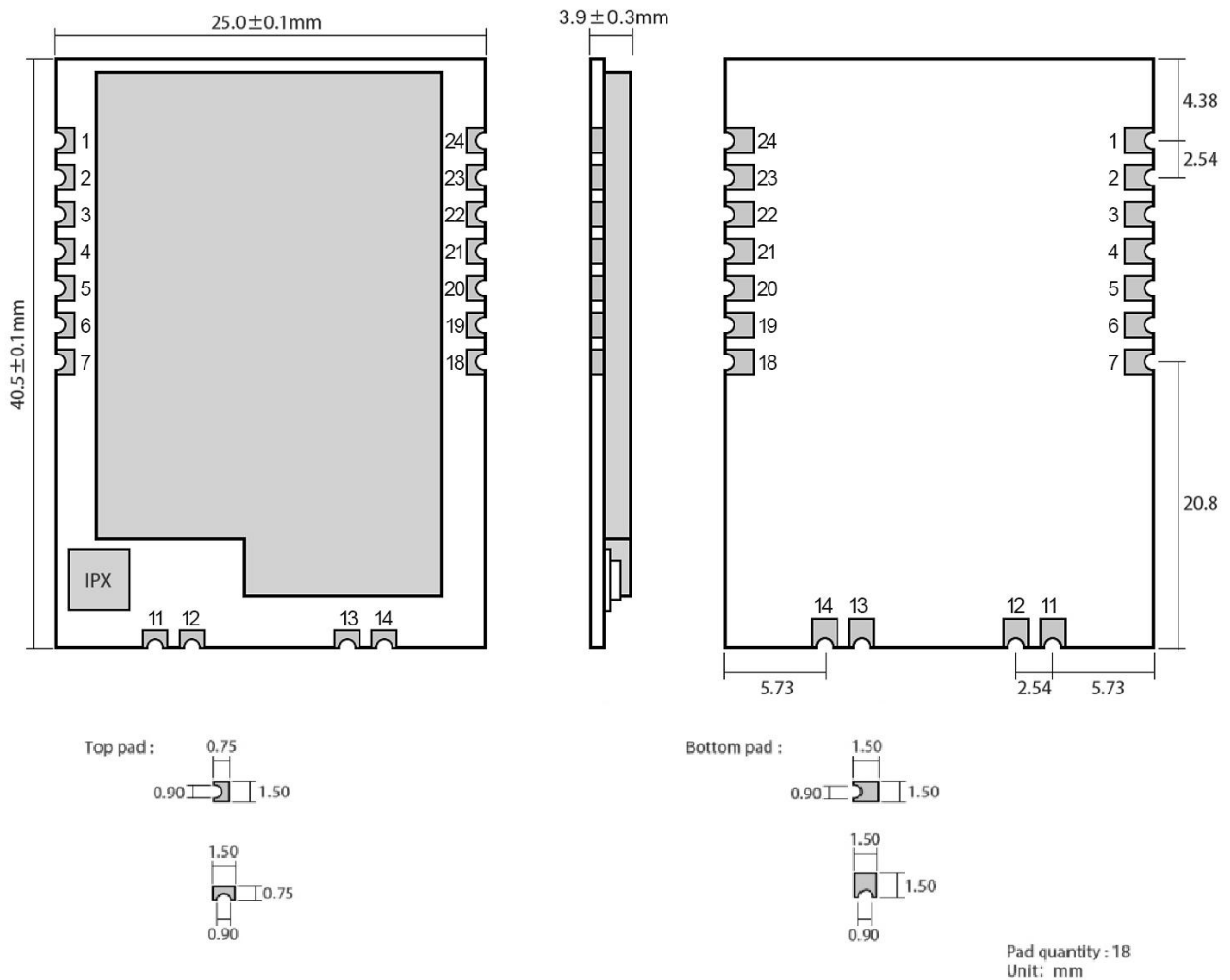

pin number	pin name	Pin direction	Pin usage
1	GND	enter	Module ground
2	VCC	enter	Module power positive reference, voltage range: 3.3 ~ 5.5V DC
3	AUX	output	Used to indicate the working status of the module; the user wakes up the external MCU, and outputs a low level during the initialization of the power-on self-test; (can be suspended)
4	TXD	output	TTL serial port output, connected to external RXD input pin;
5	RXD	enter	TTL serial port input, connected to the external TXD output pin;
6	M1	Input (very weak pull-up)	Cooperate with M0 to determine the 4 working modes of the module (not floating, if not used, it can be grounded)
7	M0	Input (very weak pull-up)	Cooperate with M1 to determine the 4 working modes of the module (not floating, if not used, it can be grounded)
11	ANT	output	Antenna interface (high-frequency signal output, 50 ohm characteristic impedance)
12	GND		Fixedly
13	GND		Fixedly
14	GND		Fixedly
18	NC	-	NC pin, this pin needs to be suspended (for subsequent expansion)
19	NC	-	NC pin, this pin needs to be suspended (for subsequent expansion)
20	NC	-	NC pin, this pin needs to be suspended (for subsequent expansion)
21	NC	-	empty feet
22	RESET	enter	Module reset pin
23	GND	enter	Module ground
24	NC	-	empty feet

4 Recommended Connection Diagram

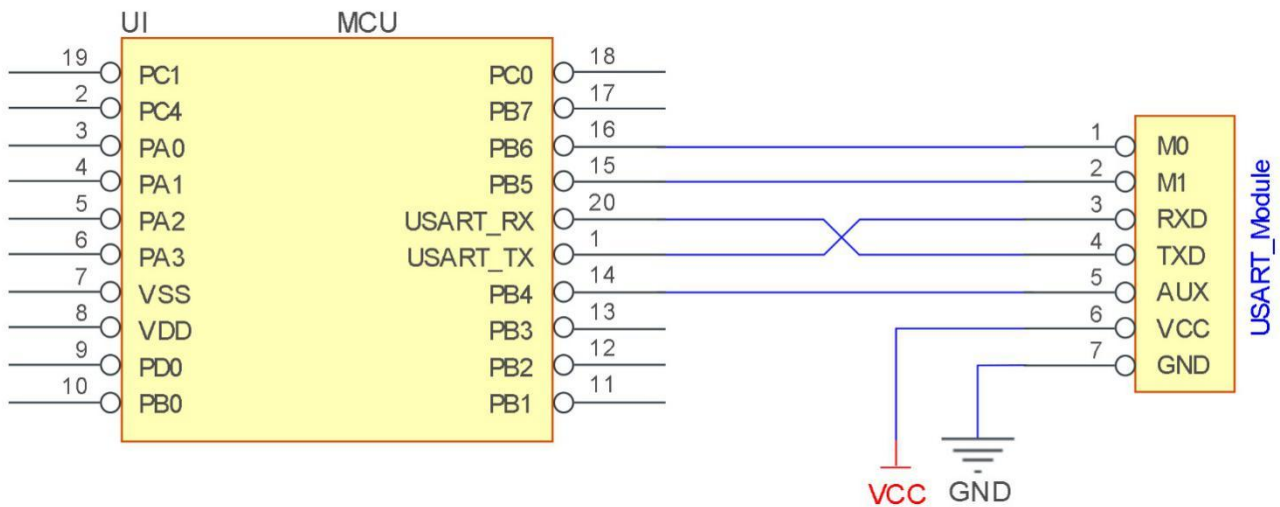

serial number	A brief description of the connection between the module and the microcontroller (the above figure takes the STM8L microcontroller as an example)
1	The wireless serial port module is TTL level, please connect it with TTL level MCU.
2	For some 5V microcontrollers, it may be necessary to add 4 ~ 10K pull-up resistors to the TXD and AUX pins of the module.

5 Function Detailed Explanation

5.1 Fixed - point launch

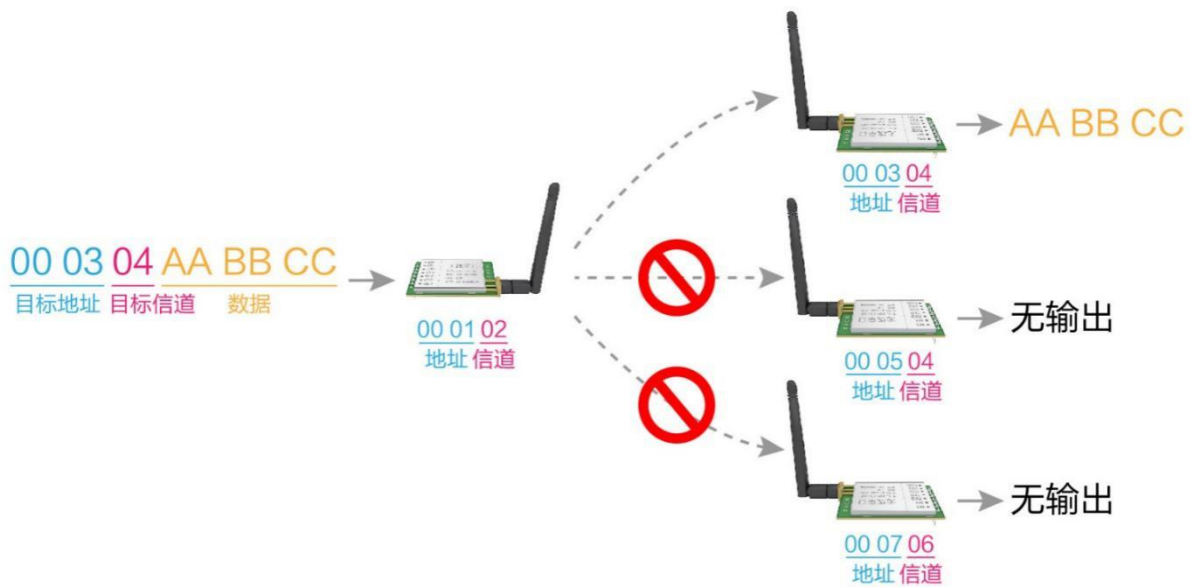

5.2 Broadcast transmission

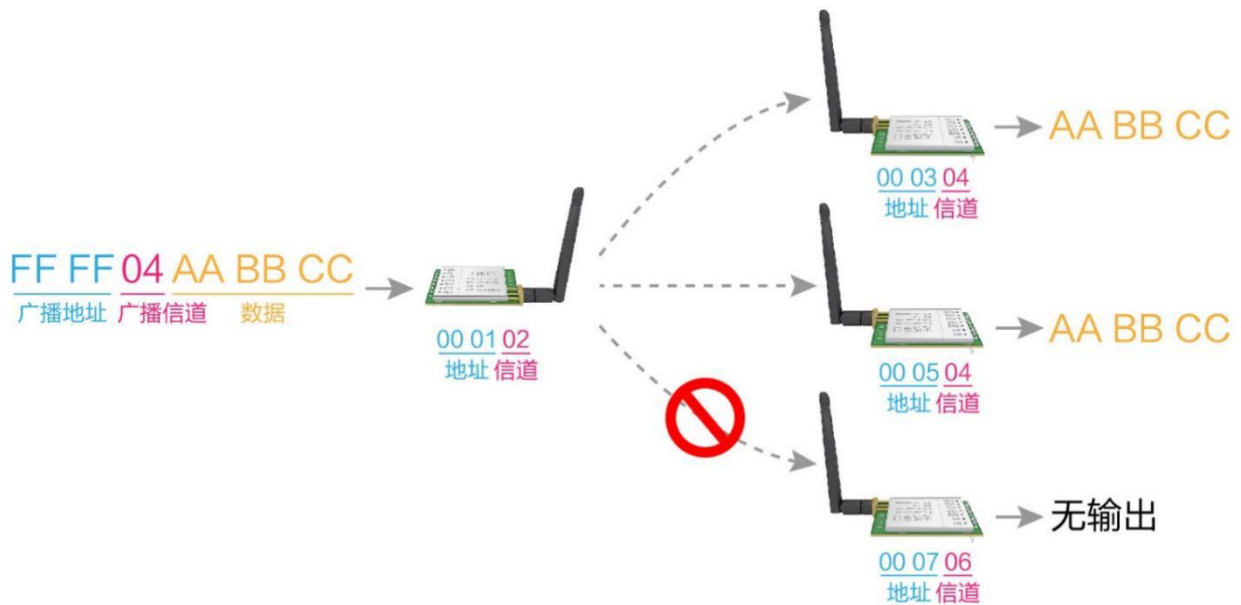

5.3 Broadcast address

- Example: Set the address of module A to 0xFFFF, and the channel to 0x04.
- When module A is used as a transmitter (same mode, transparent transmission mode), all receiving modules under the 0x04 channel can receive data to achieve the purpose of broadcasting.

5.4 Listening address

- Example: Set the address of module A to 0xFFFF, and the channel to 0x04.
- When module A is used as a receiver, it can receive all the data under the 0x04 channel to achieve the purpose of monitoring.

5.5 Module reset

- After the module is powered on, AUX will immediately output low level, and perform hardware self-test, and set the working mode according to user parameters;
During this process, AUX keeps low level, and after the completion, AUX outputs high level, and starts to work normally according to the working mode combined by M1 and M0;
Therefore, the user needs to wait for the rising edge of AUX as the starting point for the normal operation of the module.

5.6 Detailed explanation of AUX

- AUX is used for wireless transceiver buffer indication and self-test indication.
- It indicates whether the module has data that has not been transmitted through the wireless, or whether the received wireless data has not been sent through the serial port, or the module is in the process of initializing self-test.

5.6.1 Serial port data output indication

- Used to wake up the external MCU in sleep;

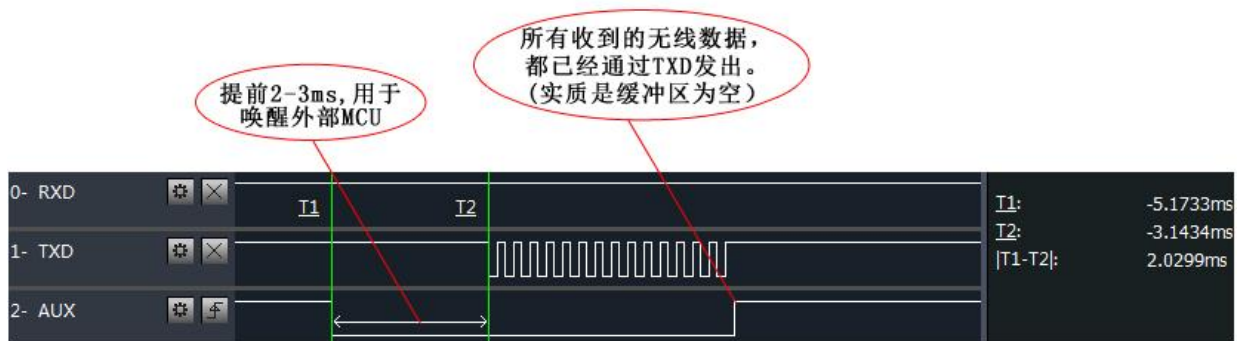

模块串口外发数据时，AUX引脚时序图

5.6.2 Wireless transmission indication

- Buffer is empty: the data in the internal 1000-byte buffer is written to the wireless chip (automatically subpackaged) ;
When AUX=1, the user continuously initiates data less than 1000 bytes, which will not overflow ;
When AUX=0, the buffer is not empty: the data in the internal 1000-byte buffer has not been written into the wireless chip and the transmission is started. At this time, the module may be waiting for the end of user data to time out, or it is transmitting wireless packets..

【Note】 : When AUX=1, it does not mean that all serial port data of the module has been transmitted wirelessly, or the last packet of data may be being transmitted.

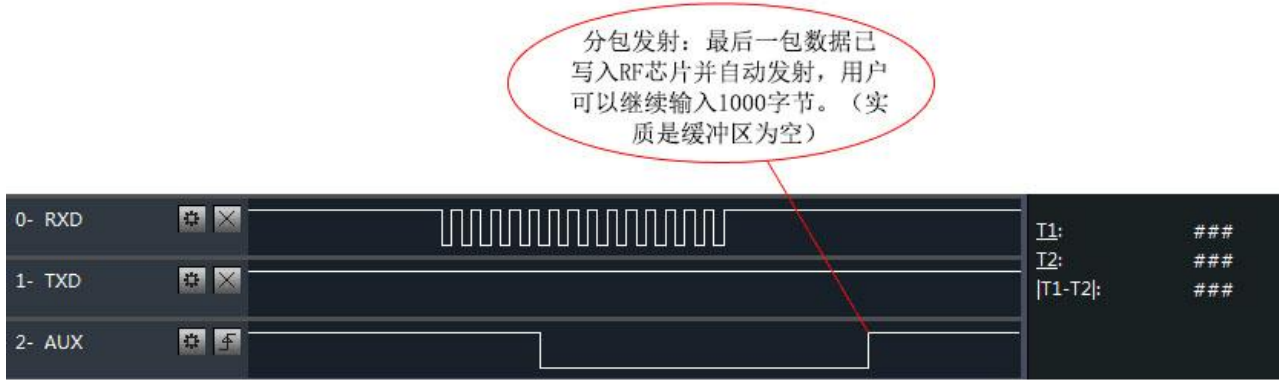

模块接收串口数据时，AUX引脚时序图

5.6.3 The module is being configured

- only on reset and when exiting sleep mode;

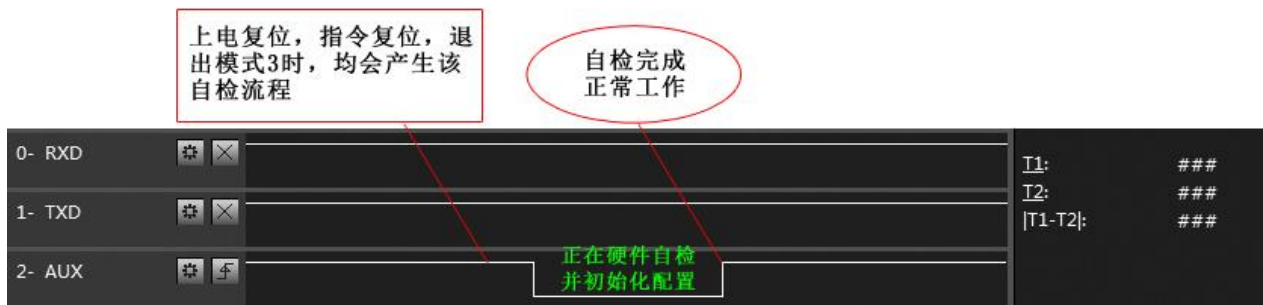

自检期间，AUX引脚时序图

5.6.4 Precautions _

serial number	Notes on AUX
1	The above function 1 and function 2, output low level priority, that is: if any output low level condition is met, AUX will output low level; When all low-level conditions are not met, AUX outputs high level.
2	When the AUX outputs a low level, it means the module is busy, and the working mode detection will not be performed at this time; When the module AUX outputs a high level within 1ms, the mode switching will be completed.
3	After the user switches to a new working mode, at least 2ms after the rising edge of AUX, the module will actually enter this mode; If AUX is always at high level, then the mode switch will take effect immediately.
4	When the user enters other modes from mode 3 (sleep mode) or during the reset process, the module will reset the user parameters, during which AUX outputs low level.
5	Due to the characteristics of the LoRa modulation method, the information transmission delay is much longer than that of FSK. It is recommended that customers do not transmit large amounts of data at low airspeeds to avoid communication abnormalities caused by data loss due to data accumulation.

6 Working Mode

The module has four working modes, which are set by pins M1 and M0; the details are shown in the table below:

mode (0-3)	M1	M0	Mode introduction	Remark
0 transfer mode	0	0	Serial port open, wireless open, transparent transmission	Support special command air configuration
1 WOR mode	0	1	Can be defined as WOR sender and WOR receiver	Support air wake
2 configuration mode	1	0	Users can access the registers through the serial port to control the working status of the module	
3 deep sleep	1	1	Module goes to sleep	

6.1 Mode switching

serial number	Remark
1	<ul style="list-style-type: none"> The user can combine the high and low levels of M1 and M0 to determine the working mode of the module. 2 GPIOs of MCU can be used to control mode switching; After changing M1 and M0: If the module is idle, it can start working in the new mode after 1ms; If the module has serial port data that has not been transmitted wirelessly, it can enter a new working mode only after the transmission is completed; If the module receives the wireless data and sends out the data through the serial port, it needs to send the data before entering the new working mode; So the mode switch can only be valid when AUX output 1, otherwise the switch will be delayed.
2	<ul style="list-style-type: none"> For example, if the user continuously inputs a large amount of data and performs mode switching at the same time, the switching mode operation at this time is invalid; the module will only perform new mode detection after processing all user data; Therefore, the general suggestion is: detect the output state of the AUX pin, wait for 2ms after outputting a high level, and then switch.
3	<ul style="list-style-type: none"> When the module is switched from other modes to sleep mode, if there is data that has not been processed; The module will enter the sleep mode after processing the data (including receiving and sending). This feature can be used for fast sleep to save power consumption; for example: the transmitter module works in mode 0, the user initiates serial port data "12345", and then does not have to wait for the AUX pin to be idle (high level), it can directly switch to sleep mode, and the main MCU of the user will sleep immediately, and the module will automatically enter the sleep within 1ms after sending all the user data through wireless; Thereby saving the working time of the MCU and reducing power consumption.
4	<ul style="list-style-type: none"> Similarly, any mode switching can take advantage of this feature. After the module processes the current mode event, it will automatically enter the new mode within 1ms; thus saving the user from the work of querying AUX and achieving the purpose of fast switching ; For example, switch from transmitting mode to receiving mode; the user MCU can also go to sleep in advance before mode switching, and use the external interrupt function to obtain AUX changes, so as to perform mode switching.
5	<ul style="list-style-type: none"> This operation mode is very flexible and efficient, and it is completely designed according to the user's MCU operation convenience, and can reduce the workload of the entire system as much as possible, improve system efficiency, and reduce power consumption.

6.2 General Mode (Mode 0)

type	When M0 = 0, M1= 0, the module works in mode 0
emission	Users can input data through the serial port, and the module will start wireless transmission.
take over	The wireless receiving function of the module is turned on, and the wireless data will be output through the TXD pin of the serial port after receiving the wireless data.

6.3 WOR mode (mode 1)

type	When M0 = 1, M1= 0, the module works in mode 1
emission	When defined as the transmitter, the wake-up code for a certain period of time will be automatically added before the launch
take over	Data can be received normally, and the receiving function is equivalent to mode 0

6.4 Configuration Mode (Mode 2)

type	When M0 = 0, M1= 1, the module works in mode 2
emission	radio off
take over	wireless reception off
configuration	User can access registers to configure module operating status

6.5 Deep Sleep Mode (Mode 3)

type	When M0 = 1, M1= 1, the module works in mode 3
emission	Unable to transmit wireless data.
take over	Unable to receive wireless data.
Notice	When entering other modes from sleep mode, the module will reconfigure the parameters, during the configuration process, A UX remains low; Output high level after completion, so it is recommended that users detect the rising edge of AUX.

7 Register Read and Write Control

7.1 Instruction format

configuration mode (mode 2: M1=1, M0=0), the list of supported commands is as follows (**when setting, only 9600, 8N1formats are supported**):

serial number	command format	Detailed description
1	set register	<p>Command: C0+start address+length+parameter Response: C1+start address+length+parameter</p> <p>Example 1: Configure the channel as 0x09 Instruction start address length parameter Send: C0 05 0109 Return: C105 0109</p> <p>Example 2: Simultaneously configure module address (0x1234), network address (0x00), serial port (9600 8N1), airspeed (2.4k) Send: C0 00 04 12 34 00 61 Return: C100 04 12 34 00 61</p>
2	read register	<p>Command: C1+start address+length Response: C1+start address+length+parameter</p> <p>Example 1: Reading a Channel Instruction start address length parameter Send: C105 01 Return: C105 0109</p> <p>Example 2: Simultaneously read module address, network address, serial port, and airspeed Send: C100 04 Return: C100 04 12 34 00 61</p>
3	set temporary register	<p>Command: C2 + start address + length + parameters Response: C1+ start address + length + parameters</p> <p>Example 1: Configure the channel as 0x09 Instruction start address length parameter Send: C2 05 0109 Return: C105 0109</p> <p>Example 2: Simultaneously configure module address (0x1234), network address (0x00), serial port (9600 8N1), airspeed (2.4k) Send: C2 00 04 12 34 00 61 Return: C100 04 12 34 00 61</p>
5	wireless configuration	<p>Instructions: CF CF + regular instructions Response: CF CF + Regular Response</p> <p>Example 1: The wireless configuration channel is 0x09 Wireless instruction header instruction start address length parameter Send: CF CF C0 05 0109 Return: CF CF C105 0109</p> <p>Example 2: Simultaneous wireless configuration module address (0x1234), network address (0x00), serial port (9600 8N1), airspeed (2.4k) Send: CF CF C0 00 04 12 34 00 61 Return: CF CF C100 04 12 34 00 61</p>

6	wrong format	format error response FF FF FF
---	--------------	-----------------------------------

7.2 Register description

serial number	read and write	name	describe	Remark			
00H	read/write	ADDH	ADDH (default 0)	Module address high byte and low byte ; Note: When the module address is equal to FFFF, it can be used as the broadcast and listening address, that is, the module will not perform address filtering at this time			
01H	read/write	ADDL	ADDL (default 0)				
02H	read/write	NETID	NETID (default 0)	Network address, used to distinguish the network ; When communicating with each other, they should be set to be the same.			
0 3H	read/write	REG0	7	6	5	U ART serial port rate (bps)	For the two modules communicating with each other, the serial port baud rate can be different , and the verification method can also be different ; When continuously transmitting large data packets, users need to consider the data blocking caused by the same baud rate, and may even be lost ; It is generally recommended that the baud rate of both communication parties be the same.
			0	0	0	The serial port baud rate is 1200	
			0	0	1	The serial port baud rate is 2400	
			0	1	0	The serial port baud rate is 4800	
			0	1	1	The serial port baud rate is 9600 (default)	
			1	0	0	The serial port baud rate is 19200	
			1	0	1	The serial port baud rate is 38400	
			1	1	0	The serial port baud rate is 57600	
			1	1	1	The serial port baud rate is 115200	
			4	3	serial check digit		
		0	0	8 N1(default)			
		0	1	8 O1			
		1	0	8 E1			
		1	1	8 N1(equivalent to 0 0)		The air speed of both communication parties must be the same ; air rate, the smaller the delay and the shorter the transmission distance.	
		2	1	0	Wireless air rate (bps)		
		0	0	0	Air rate 2.4k		
		0	0	1	Air rate 2.4k		
		0	1	0	Air rate 2.4k (default)		
0	1	1	Air rate 4.8k				
1	0	0	Air rate 9.6k				
1	0	1	Air rate 19.2k				

			1	1	0	Air rate 38.4k	
			1	1	1	Air rate 62.5k	
0 4H	read/w rite	REG1	7	6	subcontract settings		The data sent by the user is less than the sub-packet length, and the serial port output of the receiving end presents an uninterrupted continuous output ; If the data sent by the user is larger than the length of the packet, the serial port at the receiving end will output the packet.
			0	0	2 40 bytes (default)		
			0	1	128 bytes		
			1	0	6 4 bytes		
			1	1	3 2 bytes		
			5	RSSI ambient noise enable		Enable command (subpackage setting, transmit power are default parameters, configuration mode): C0 04 0120 ; After enabling, the command C0 C1C2 C3 can be sent in the transmission mode or WOR transmission mode to read the register ; Register 0x00: current ambient noise RSSI ; Register 0X01: RSSI at Last Data Received (Current channel noise is: dBm = -(256 - RSSI)) ; Instruction format: C0 C1C2 C3+start address+read length ; Return: C1+ address + read length + read valid value; for example: send C0 C1C2 C3 00 01 Return C100 01RSSI (the address can only start from 0 0)	
			0	disabled (default)			
			1	enable			
			4	3	2	reserve	
			1	0	transmit power		The relationship between power and current is non-linear, and the power supply efficiency is the highest at maximum power ; Current does not decrease proportionally with power reduction.
			0	0	3 3dBm (default)		
			0	1	30dB m		
			1	0	27dB m		
			1	1	24dB m		
0 5H	read/w rite	REG2	Channel Control (CH) 0-80 represent a total of 81 channels				Actual Frequency = 850.125 + CH *1M
0 6H	read/w rite	REG3	7	enable rssi byte		When enabled, the module receives wireless data and outputs it through the serial port TXD, followed by an RSSI strength byte.	
			0	disabled (default)			
			1	enable			
			6	transfer method		During fixed-point transmission, the module will recognize the first three bytes of serial port data as: address high + address low + channel, and use it as the wireless transmission target.	
			0	transparent transmission (default)			
			1	Fixed-point transmission		After the relay function is enabled, if the target address is not the module itself, the module will start a forwarding ; In order to prevent data return, it is recommended to use it in conjunction with the fixed-point mode ; that is, the destination address is different from the source address.	
			5	relay function			
			0	Disable relay function (default)		After enabled, wireless data will be monitored before transmission, which can avoid interference to a certain extent, but may cause data delay ;	
			1	Enable relay function			
			4	LBT enable _		The maximum stay time of LBT is 2 seconds, and it will be issued forcibly when it reaches 2 seconds.	
			0	disabled (default)			
1	enable		Only valid for mode 1;				
3	WOR mode transceiver control						

			0	W OR receiver (default) The module cannot transmit data and works in WOR monitoring mode. The monitoring cycle is shown below (WOR cycle), which can save a lot of power consumption.			<p>After the WOR receiver receives the wireless data and outputs it through the serial port, it will wait for 1000ms before entering WOR again. During this period, the user can input the serial data and return it through the wireless ;</p> <p>Each serial port byte will be refreshed for 1000ms ;</p> <p>The user must initiate the first byte within 1000ms.</p>
			1	W OR Transmitter The transceiver of the module is turned on, and when transmitting data, a wake-up code for a certain period of time is added.			
			2	1	0	W OR cycle	
			0	0	0	500ms _	
			0	0	1	1000ms _	
			0	1	0	1500ms _	
			0	1	1	2000ms _	
			1	0	0	2500ms _	
			1	0	1	3000ms _	
			1	1	0	3500ms _	
			1	1	1	4000ms _	<p>Only valid for mode 1;</p> <p>Period T= (1+WOR) *500ms , the maximum is 4000ms , and the minimum is 500ms ;</p> <p>the WOR monitoring interval period, the lower the average power consumption, but the greater the data delay;</p> <p>The sending and receiving parties must be consistent (very important)</p>
0 7H	Write	CRYPT_H	key high byte (default 0)			<p>Write only, read returns 0 ;</p> <p>Used for encryption to avoid interception of air wireless data by similar modules ;</p> <p>Inside the module, these two bytes will be used as calculation factors to transform and encrypt the wireless signal in the air.</p>	
0 8H	Write	CRYPT_L	Key low byte (default 0)				
8 0H ~8 6H	read	PIDs	Product information 7 bytes			Product information 7 bytes	

7.3 Factory Default Parameters

model	Factory default parameter value: C0 00 09 00 00 00 62 00 12 03 00 00						
Module model	frequency	address	channel	air speed	baud rate	Serial format	transmit power
E22-900T33S	868.125MHz	0x0000	0x12	2.4kbps	9600	8N1	33 dbm

8 AT command

- AT commands are used in configuration mode, AT commands are divided into three categories: command commands, setting commands and query commands;
- The user can query the AT command set supported by the module through "AT+HELP=?", and the baud rate adopted by the AT command is 9600 8N0;
- When the input parameter exceeds the range, it will be restricted. Please do not let the parameter exceed the range to avoid unknown situations.

8.1AT command table

command instruction	describe	example	Example description
AT+IAP (use with caution, please refer to 8.3 IAP Upgrade Notes in this article for details)	Enter IAP upgrade mode	AT+IAP	Enter IAP upgrade mode
AT+RESET	device restart	AT+RESET	device restart
AT+DEFAULT	The configuration parameters are restored to default and the device reboots	AT+DEFAULT	The configuration parameters are restored to default and the device reboots

set command	describe	example	Example description
AT+UART=baud,parity	Set baud rate and parity	AT+UART=3,0	Set the baud rate to 9600, 8N0
AT+RATE=rate	set air speed	AT+RATE=7	Set the air rate to 62.5K
AT+PACKET=packet	Set packet length	AT+PACKET=0	Set the packet to 240 bytes
AT+WOR=role	Set WOR role	AT+WOR=0	Set to WOR reception
AT+POWER=power	Set send power	AT+POWER=0	Set the transmit power to 22dBm
AT+TRANS=mode	Set send mode	AT+TRANS=1	Set to fixed point mode
AT+ROUTER=router	Set repeater mode	AT+ROUTER=1	Set to repeater mode
AT+LBT=lbt	Set the Listen Before Talk function switch	AT+LBT=1	Set to enable, refer to section 7.2 LBT enable for details
AT+ERSSI=erssi	Set ambient noise RSSI switch	AT+ERSSI=1	Set to enable, refer to Section 7.2 RSSI Environmental Noise Function for details
AT+DRSSI=data_rssi	Set receive data RSSI switch	AT+DRSSI=1	Receive data RSSI function open
AT+ADDR=addr	Set module address	AT+ADDR=1234	Set the module address to

			1234
AT+CHANNEL=channel	Set the working channel of the module	AT+CHANNEL=23	Set the frequency to 433.125M
AT+NETID=netid	set network ID	AT+NETID=2	Set the network ID to 2
AT+KEY=key	set module key	AT+KEY=1234	Set the module key to 1234
AT+DELAY=delay	Set WOR delay sleep time	AT+DELAY=1000	Set the WOR delay sleep time to 1000ms
AT+SWITCH=switch	Set software switching mode switch	AT+SWITCH=1	Set to open, allow software switching

query command	describe	return example	Example description
AT+HELP=?	Query the AT command table		Return to AT command table
AT+DEVTYPE=?	Query module model	DEVTYPE=E29-400T22S/D	return module model
AT+FWCODE=?	Query firmware code	FWCODE=7432-0-10	return firmware version
AT+UART=?	Query baud rate and checksum	AT+UART=3,0	Return baud rate 9600, 8N0
AT+RATE=?	Query air rate	AT+RATE=7	The return air rate is 16.4K
AT+PACKET=?	Query packet length	AT+PACKET=0	The return packet is 240 bytes
AT+WOR=?	Query WOR roles	AT+WOR=0	The return is WOR reception
AT+POWER=?	Query sending power	AT+POWER=0	Return transmit power is 22dBm
AT+TRANS=?	query sending mode	AT+TRANS=1	return to fixed-point mode
AT+ROUTER=?	Query relay mode	AT+ROUTER=1	Return to repeater mode
AT+LBT=?	Query the function switch of Listen Before Talk	AT+LBT=1	Return LBT switch state
AT+ERSSI=?	Query the ambient noise RSSI switch	AT+ERSSI=1	Returns the ambient noise switch status
AT+DRSSI=?	Query RSSI output	AT+DRSSI=1	The return channel RSSI function is enabled
AT+ADDR=?	Query module address	AT+ADDR=1234	The return module address is 1234
AT+CHANNEL=?	Query the working channel of the module	AT+CHANNEL=23	The return frequency is 433.125M
AT+NETID=?	Query network ID	AT+NETID=2	The return network ID is 2
AT+KEY=?	query module key	Reading is not supported (security considerations)	return ERR
AT+DELAY=?	Query WOR delay sleep time	AT+DELAY=1000	Return WOR delay sleep time is 1000ms

8.2 AT parameter analysis

When the serial port receives the correct command, the serial port will return "command=OK", otherwise it will return "=ERR"

command parameter	parameter meaning
Baud (serial port baud rate)	0:1200 1:2400 2:4800 3:9600 4:19200 5:38400 6 : 57600 7:115200
Parity (serial check digit)	0:8N1 1:8O1 2:8E1 3:8N1
Rate (air rate)	0:2.4K 1:2.4K 2:2.4K 3:4.8K 4:9.6K 5:19.2K 6:38.4K 7:62.5K
Packet (packet length)	0: 240 1: 128 2:64 _ 3:32 _
Role (WOR role)	0: receive 1: send
Period (WOR period)	0 : 500ms 1: 10 00 ms 2 : 1500 ms 3: 20 00 ms 4 : 2500 ms 5: 30 00 ms 6 :3 500 ms 7: 4000 ms
Power (transmission power)	0:33dBm 1:30dBm 2:27dBm 3:24dBm
Mode (transmission mode)	0: transparent 1: fixed point
Router (relay mode)	0: off 1: open
LBT (listen before talk)	0: off 1: open
Erssi (environmental RSSI)	0: off 1: open
Data_rssi (Data RSSI)	0: off 1: open
Addr (module address)	Module address 0~65535 (decimal system)
Channel (module channel)	Module channel 0~83 (decimal system)
Netid (Network ID)	Module network 0~255 (decimal)
Key _	Module key 0~65535 (decimal)
Delay (WOR delayed sleep)	Delay sleep 0~65535 (decimal system)

8.3 Precautions for IAP upgrade

If the customer needs to upgrade the firmware, he needs to find the corresponding BIN file provided by the official, and then use the official host computer to upgrade the firmware. Generally, the user does not need to upgrade the firmware. Please do not use the "AT+IAP" **command**.

The pins necessary for the upgrade must be led out (M1, M0, AUX, TXD, RXD, VCC, GND), and then send the "AT+IAP" command in the configuration mode to enter the upgrade mode. If you need to exit the IAP upgrade mode, you need to **keep Power on and wait for 60 seconds, the program will automatically exit, otherwise it will enter the upgrade mode infinitely even if it is restarted.**

After entering the upgrade mode, the baud rate will automatically switch to 115200 until it exits automatically, during which there will be log output.

9 Use of relay networking mode

serial number	Description of relay mode
1	After setting the relay mode through the configuration mode, switch to the general mode and the relay starts to work.
2	In the repeater mode, ADDH and ADDL are no longer used as module addresses, but correspond to NETID forwarding pairs respectively. If one of the networks is received, it will be forwarded to another network ; The repeater's own network ID is invalid.
3	In relay mode, the relay module cannot send and receive data, and cannot operate with low power consumption.
4	When the user enters other modes from mode 3 (sleep mode) or during the reset process, the module will reset the user parameters, during which AUX outputs low level.

Relay networking rules description:

- 1、 Forwarding rules, the relay can bidirectionally forward data between two NETIDs.
- 2、 In relay mode, ADDH\ADDL is no longer used as a module address, but as a NETID forwarding pair.

As shown in the picture:

① relay

"Node 1" has a NETID of 08.

"Node 2" has a NETID of 33.

The ADDH\ADDL of trunk 1 are 08 and 33 respectively.

So the signal sent by node 1(08) can be forwarded to node 2 (33)

At the same time, node 1 and node 2 have the same address, so the data sent by node 1 can be received by node 2.

② Secondary relay

The ADDH\ADDL of relay 2 are 33 and 05 respectively.

So relay 2 can forward the data of relay 1 to network NETID:05.

Thus node 3 and node 4 can receive node 1 data. Node 4 outputs data normally, and node 3 has a different address from node 1, so no data is output.

③ Two-way relay

Configuration as shown in the figure: the data sent by node 1 can be received by nodes 2 and 4, and the data sent by nodes 2 and 4 can also be received by node 1.

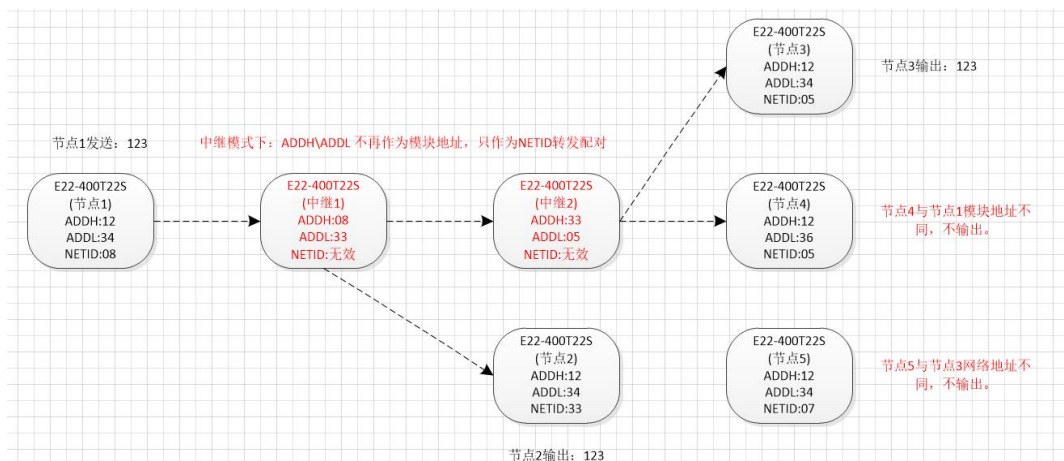

10 PC Configuration Instructions

- The figure below shows the display interface of the E22-900T22S configuration upper computer. The user can switch to the command mode through M0 and M1, and quickly configure and read parameters on the upper computer.



- In the configuration host computer, the module address, frequency channel, network ID, and key are all in decimal display mode; the value range of each parameter:

Network address: 0~65535

Frequency channel: 0~83

Network ID: 0~255

Key: 0~65535

- When using the host computer to configure the relay mode, the user needs to pay special attention. Since the parameters in the host computer are in decimal display mode, the module address and network ID need to be converted to decimal when filling in;

For example, if the network ID input by transmitter A is 02, and the network ID input by receiver B is 10, then when the relay terminal R sets the module address, convert the hexadecimal value 0X020A to the decimal value 522 and fill it in as the relay terminal R module address;

That is to say, the module address value that the relay terminal R needs to fill in at this time is 522.

11 Hardware Design

- It is recommended to use a DC regulated power supply to power the module, the power supply ripple factor should be as small as possible, and the module must be reliably grounded;
- Please pay attention to the correct connection of the positive and negative poles of the power supply, such as reverse connection may cause permanent damage to the module;
- Please check the power supply to ensure that it is between the recommended power supply voltage, if it exceeds the maximum value, it will cause permanent damage to the module;
- Please check the stability of the power supply, the voltage cannot fluctuate greatly and frequently;
- When designing the power supply circuit for the module, it is often recommended to reserve more than 30% of the margin, and

the whole machine is conducive to long-term stable work;

- The module should be kept as far away as possible from parts with high electromagnetic interference such as power supplies, transformers, and high-frequency wiring;
- High-frequency digital traces, high-frequency analog traces, and power traces must avoid the bottom of the module. If it is really necessary to pass through the bottom of the module, assuming that the module is soldered to the Top Layer, lay copper on the top layer of the contact part of the module (all copper and Good grounding), must be close to the digital part of the module and routed in the Bottom Layer ;
- Assuming that the module is soldered or placed on the Top Layer, it is also wrong to randomly route the wires on the Bottom Layer or other layers, which will affect the stray and receiving sensitivity of the module to varying degrees ;
- Assuming that there are devices with large electromagnetic interference around the module, which will greatly affect the performance of the module, it is recommended to keep away from the module according to the intensity of the interference, and if the situation permits, proper isolation and shielding can be done;
- Assuming that there are traces with large electromagnetic interference around the module (high-frequency digital, high-frequency analog, power supply traces) will also greatly affect the performance of the module. According to the intensity of the interference, it is recommended to keep away from the module. If the situation permits, you can do it appropriately isolation and shielding;
- If the communication line uses a 5V level, a 1k-5.1k resistor must be connected in series (not recommended, there is still a risk of damage) ;
- Try to stay away from some TTL protocols whose physical layer is also 2.4GHz, for example: USB3.0;
- The antenna installation structure has a great impact on the performance of the module, so make sure that the antenna is exposed and preferably vertically upward;
- When the module is installed inside the casing, a high-quality antenna extension cable can be used to extend the antenna to the outside of the casing;
- The antenna must not be installed inside the metal shell, which will greatly weaken the transmission distance.

12 Frequently Asked Questions

12.1 The transmission distance is not ideal

- When there is a straight-line communication obstacle, the communication distance will be attenuated accordingly ;
- Temperature, humidity, and co-channel interference will increase the communication packet loss rate ;
- The ground absorbs and reflects radio waves, and the test effect is poor when it is close to the ground ;
- Seawater has a strong ability to absorb radio waves, so the seaside test results are poor ;
- There are metal objects near the antenna, or placed in a metal case, the signal attenuation will be very serious ;
- The power register is set incorrectly, and the air speed is set too high (the higher the air speed, the closer the distance) ;
- The low voltage of the power supply at room temperature is lower than the recommended value, and the lower the voltage, the lower the output power ;
- The matching degree between the antenna and the module is poor or the quality of the antenna itself is problematic.

12.2 The module is easily damaged

- Please check the power supply to ensure that it is between the recommended power supply voltage, if it exceeds the maximum value, it will cause permanent damage to the module ;
- Please check the stability of the power supply, the voltage cannot fluctuate greatly and frequently ;
- Please ensure anti-static operation during installation and use, and high-frequency devices are electrostatically sensitive ;
- Please ensure that the humidity during installation and use should not be too high, some components are humidity sensitive devices ;
- If there is no special requirement, it is not recommended to use it at too high or too low temperature.

12.3 bit error rate is too high

- There is co-channel signal interference nearby, stay away from the source of interference or modify the frequency and channel to avoid interference;
- Unsatisfactory power supply may also cause garbled characters, so be sure to ensure the reliability of the power supply;
- Poor quality or too long extension lines and feeders will also cause high bit error rates.

13 Welding Operation Instructions

13.1 Reflow soldering temperature

Profile Features	curve feature	Sn-Pb Assembly	Pb-Free Assembly
Solder Paste	Solder paste	Sn63/Pb37	Sn96.5/Ag3/Cu0.5
Preheat Temperature min (T _{smin})	Minimum preheat temperature	100 °C	150 °C
Preheat temperature max (T _{smax})	maximum preheating temperature	150 °C	200 °C
Preheat Time (T _{smin} to T _{smax})(t _s)	Preheat time	60-120sec	60-120sec
Average ramp-up rate(T _{smax} to T _p)	average rate of ascent	3 °C /second max	3 °C /second max
Liquid Temperature (T _L)	liquidus temperature	183 °C	217 °C
Time (t _L) Maintained Above (T _L)	time above liquidus	60-90sec	30-90sec
Peak temperature (T _p)	peak temperature	220-235 °C	230-250 °C
Average ramp-down rate (T _p to T _{smax})	average rate of decline	6 °C /second max	6 °C /second max
Time 25 °C to peak temperature	25 °C to peak temperature	6 minutes max	8 minutes max

13.2 Reflow Soldering Curve

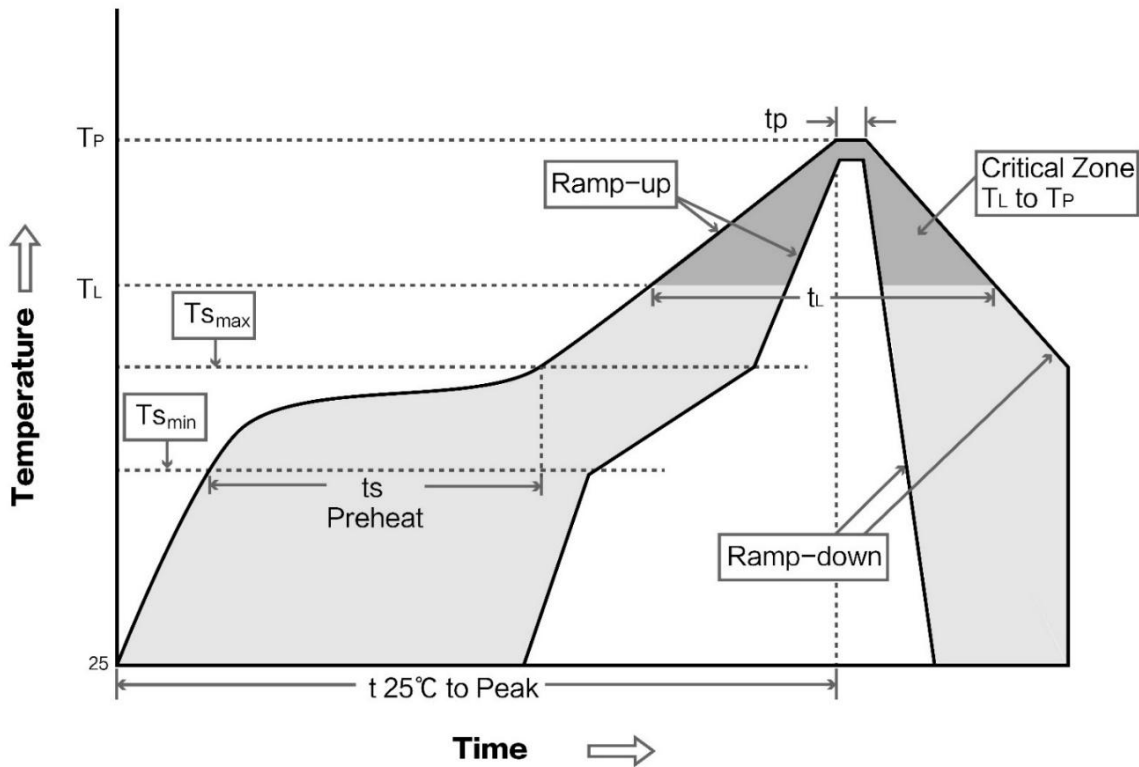

14 Related Models

Product number	Chip solution	carrier frequency Hz	transmit power dBm	Test distance km	Package form	Product Size mm	Communication Interface
E22-400T22S	SX1262	433/470M	twenty two	5	patch	16*26	UART
E22-400T22D	SX1262	433/470M	twenty two	5	in-line	21*36	UART
E22-400T30S	SX1262	433/470M	30	10	patch	20*40.5	UART
E22-400T 30D	SX1262	433/470M	30	10	in-line	24*43	UART
E22-9 00T22S	SX1262	868 / 915M -	twenty two	5	patch	16*26	UART
E22-9 00T22D	SX1262	868 / 915M -	twenty two	5	in-line	21*36	UART
E22-9 00T30S	SX1262	868 / 915M -	30	10	patch	20*40.5	UART
E22-9 00T 30 D	SX1262	868 / 915M -	30	10	in-line	24*43	UART

15 Antenna Guide

Antennas play an important role in the communication process, and often inferior antennas will have a great impact on the communication system. Therefore, our company recommends some antennas as antennas with excellent performance and reasonable price to match our wireless modules.

Product number	type	frequency Hz	interface	gain dBi	high m m	feeder c m	Features
TX 868 -JZ-5	Plastic Antenna	868M _	SMA-J	2.0 _	52	-	Ultra-short straight, omnidirectional antenna
TX 868 -JK-20	Plastic Antenna	868M _	SMA-J	3.0 _	210	-	Bendable Plastic, omnidirectional antenna
TX 868 -XP L -100	Suction cup antenna	868M _	SMA-J	3.5	290	100	Small suction cup antenna, high cost performance
TX 915 -JZ-5	Plastic Antenna	915M _	SMA-J	2.0	52	-	Ultra-short straight, omnidirectional antenna
TX 915 -JK-11	Plastic Antenna	915M _	SMA-J	2.5	110	-	Bendable Plastic, omnidirectional antenna
TX 915 -JK-20	Plastic Antenna	915M _	SMA-J	3.0 _	210	-	Bendable Plastic, omnidirectional antenna
TX 915 -XP L -100	Suction cup antenna	915M _	SMA-J	3.5	290	100	Small suction cup antenna, high cost performance

16 Batch Packaging Method

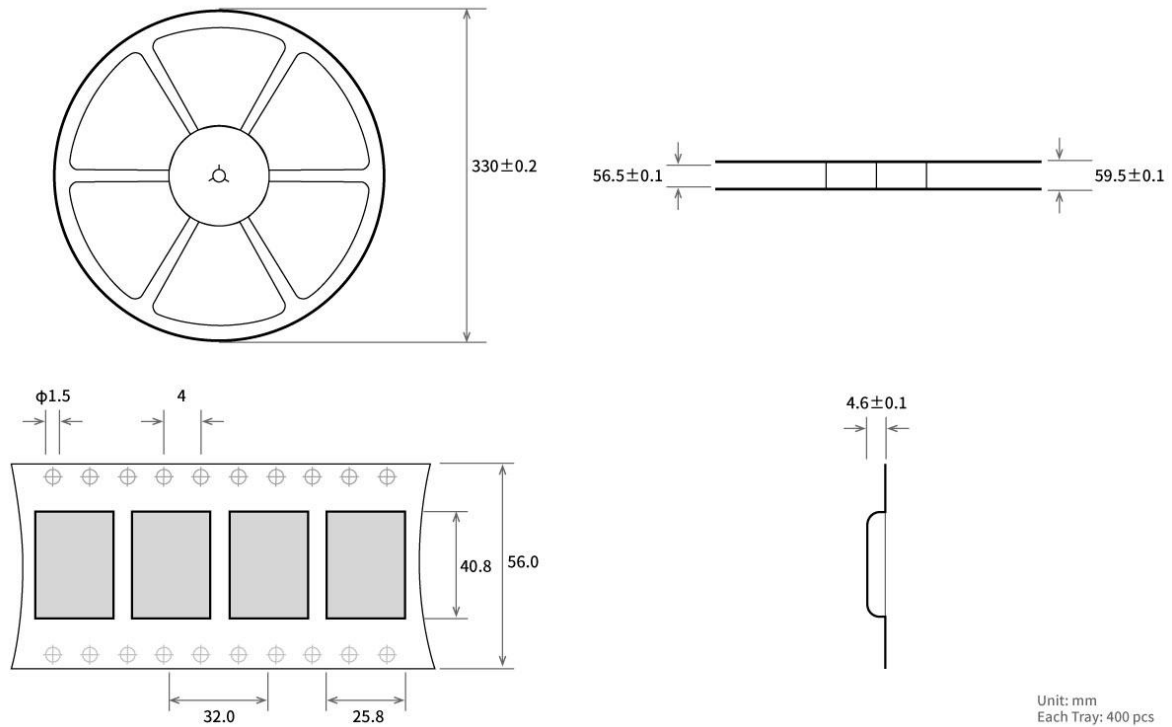

Revise History

Version	revision date	Revision Notes	Maintenance man
1.0	2023-6-6	initial version	Yan Yan
1.1	2024-1-9	Content correction	Hao

About US

Technical support: support@cdebyte.com

Documents and RF Setting download link: <https://www.cdebyte.com/>

Thank you for using Ebyte products! Please contact us with any questions or suggestions: info@cdebyte.com

Address: B5 Mould Industrial Park, 199# Xiqu Ave, High tech Zone, Chengdu, Sichuan, China



Chengdu Ebyte Electronic Technology Co.,Ltd.