



SM01-CH4A Datasheet

Methane Sensor Module



Contents

Disclaimer	3
1 Introduction	4
1.1 Brief Introduction.....	4
2 Introduction Parameters	4
3 Pins	5
4 Working Status	6
5 Communication Command	7
6 Checksum and Calculation	8
7 Application field	9
8 Precautions	9
Revision history	10
About us	10

Disclaimer

EBYTE reserves all rights to this document and the information contained herein. Products, names, logos and designs described herein may in whole or in part be subject to intellectual property rights. Reproduction, use, modification or disclosure to third parties of this document or any part thereof without the express permission of EBYTE is strictly prohibited.

The information contained herein is provided “as is” and EBYTE assumes no liability for the use of the information. No warranty, either express or implied, is given, including but not limited, with respect to the accuracy, correctness, reliability and fitness for a particular purpose of the information. This document may be revised by EBYTE at any time. For most recent documents, visit www.ebyte.com.

1 Introduction

1.1 Brief Introduction

The SM01-CH4A methane sensor module adopts semiconductor sensors and has the basic functions of a household gas leak alarm; it provides digital signals and status indications output by UART, switch signals output by buzzers, relays, and solenoid valves, and supports alarm values. reset. It can be used for the complete development of household gas leak alarms, as well as the detection components of household gas equipment gas leaks.

Main features: small size and fast response.

Main application: It is suitable for the development of the complete machine of household gas leak alarm,

And the detection components of gas leakage in household gas equipment.



2 Introduction Parameters

Product number	SM01-CH4A
Detection gas	Methane
Sensor type	Semiconductor series
Response time	≤10 s
Recovery Time	≤10 s
Operating Voltage	DC 4.8V~5.3V
Working current	≤200mA
Measuring range	0~10000PPM/0~20%LEL
Resolution	100PPM
Alarm value	Adjustable (default 4000PPM)
Precision	20°C±2°C; 55%±5%RH, ±3% LEL
Life expectancy	More than 5 years
Product standard	GB 15322.2
Interface Type	National standard GB 15322.2 1. 8pin pitch 2.0mm pin header, on the opposite side 7pin 2.0mm pin header 2. 8PIN connector with a pitch of 1.25mm (no welding by default)
Working environment	Temperature: -10 ~ 55 °C Humidity: 20% ~ 90% RH
Storage environment	Temperature: -20 ~ 60 °C Humidity: 20% ~ 65% RH
Dimensions	32mm×25mm×24mm (L×W×H)

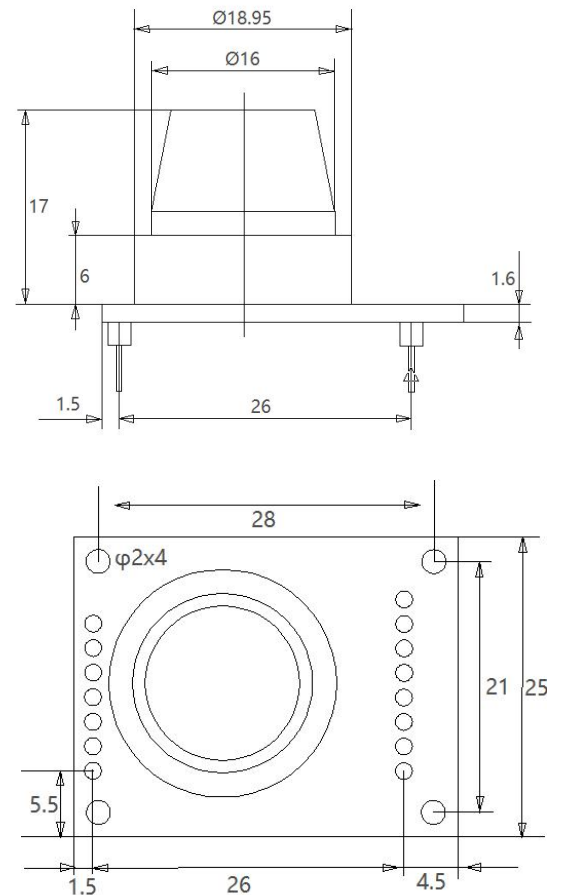

3 Pins

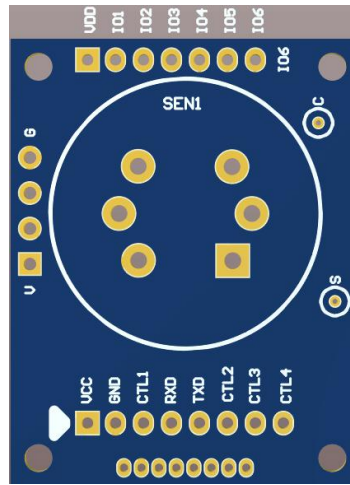

Pin No.	Name	Functions
1	VCC	5V module power input
2	GND	Reference place
3	CTL1	Control output 1: 1.in no alarm and fault state, continuous low level. 2. In the alarm state, keep high level.
4	RXD	Serial RXD data receiving pin
5	TXD	Serial TXD data sending pin
6	CTL2	Control output 2: 1.When there is no alarm and failure state, continuous low level. 2. In the alarm state, keep high level.
7	CTL3	Control output 3, buzzer control: high level buzzer
8	CTL4	Control output 4, fault light control: high level is on, low level is off
9	VDD	Module 3.3V output, output current <100mA
10	IO1	Alarm light control port: high level lights up, low level lights off
11	IO2	Power light control port: high level lights up, low level lights off
12	IO3	Self-check button input port: low-level button is valid
13	IO4	Reserve
14	IO5	Reserve
15	IO6	NC (Keep floating)

MCU Connection Schematic

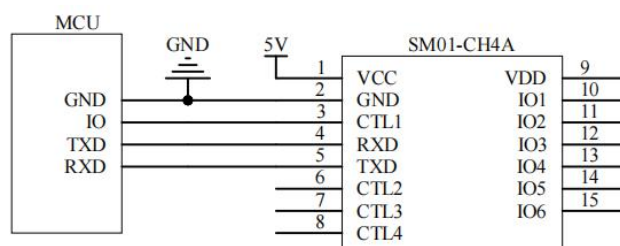

Module Alarm System Schematic

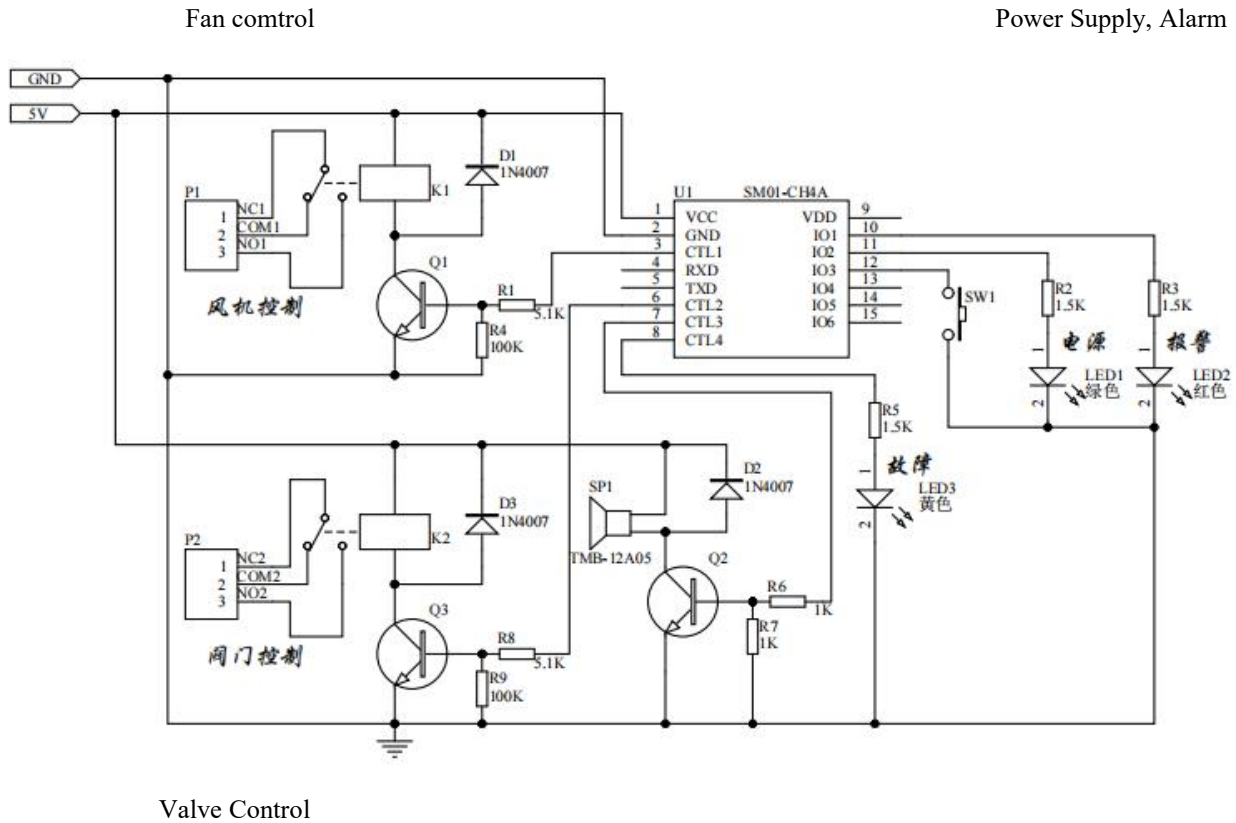

4 Working Status:

1. Power-on self-test

When the power is turned on, the three lights and running lights turn on in turn. After a delay of about 5 minutes, the buzzer beeps once to enter the normal working state, and the "power" light flashes.

2. Normal working condition

When the module has no fault or alarm status, the "power" light flashes.

In this state, press the "Self-check" button, and the module will perform sound and light self-check.

3. Alarm status

When there is no fault in the module and the gas concentration on site is higher than the alarm setting value, the "alarm" light is always on, the buzzer emits a rapid sound, and a control signal is output. At this time, you can press the "Self-check" button to mute the sound.

When the gas concentration drops to within the alarm setting value, the module automatically returns to the normal working state.

4. Fault status

When the sensor fails, the "fault" light is always on, and the buzzer sounds intermittently.

Working status	Fault light (yellow recommended)	Warning light (recommended red)	Power light (green recommended)	buzzer
normal status	Off	Off	Flashing	silent

Fault state	On	Off	Off	Intermittent tweet
Alarm status	Off	On	Off	Keep tweeting
Self-check status	Blinking			Keep beeping 5 times

5. **Self-check button:** press the "self-check" button in the normal state to perform self-check; in the alarm state, press the "self-check" button to mute the alarm.

5 Communication Command

5.1. Settings for Command:

Baud rate	9600
Data bit	8 bit
Stop bit	1 bit
Check Digit	no

5.2 Command

5.2.2 Query command

Query command format

0	1	2	3	4	5	6	7	8
Start	Reserve	Command	Type	Reserve	Reserve	Reserve	Reserve	Check
0xFF	0x01	0x86	0xXX	0x00	0x00	0x00	0x00	0xXX

Note: 0x00- query concentration, 0x02- query software version number.

Response data format

0	1	2	3	4	5	6	7	8
Start bit	Command	Gas High(PPM)	Gas Low(PPM)	Software Version High	Software Version Low	Gas High(PPM)	Gas Low(PPM)	Check
0xFF	0x86	0xXX	0xXX	0xXX	0xXX	0xXX	0xXX	0xXX

When querying the concentration, the high and low digits of the software version are 0x00; when querying the software version number, the high and low digits of the concentration are 0x00.

High byte of gas concentration (the highest digit is the 8th digit is the sensor failure judgment)

Note: Sensor failure judgment: return 1: sensor is faulty; return 0: sensor is not faulty;

Gas concentration value = lower 7 bits of gas concentration high byte * 256 + low gas concentration

Issue command: FF 01 86 00 00 00 00 00 79 //Query concentration

Reply command: FF 86 00 00 00 00 00 00 7A //Concentration value 0

FF 86 80 00 00 00 80 00 7A //Sensor failure

Issue command: FF 01 86 02 00 00 00 00 77 //Query software version

Reply command: FF 86 00 00 00 00 00 00 7A //Version 0.0

5.2.3 Set alarm command

Setting Command

0	1	2	3	4	5	6	7	8
Start	Reserve	Reserve	Command	Gas High(PPM)	Gas Low(PPM)	Reserve	Reserve	Check
0xFF	0x01	0x01	0x01	0xXX	0xXX	0x00	0x00	0xXX

Reply Command

0	1	2	3	4	5	6	7	8
Start	Reserve	Reserve	Command	Gas High(PPM)	Gas Low(PPM)	Reserve	Reserve	Check
0xFF	0x01	0x01	0xXX	0xXX	0xXX	0x00	0x00	0xXX

Status bit: 0x00-success; 0x01-failure.

Issue the command: FF 01 01 01 0F A0 00 00 4E //Set the alarm value 4000PPM (default alarm value)

FF 01 01 01 0B B8 00 00 3A //Set alarm value 3000PPM

Reply command: FF 01 01 00 0B B8 00 00 3B //Set successfully, the alarm value is 3000PPM

FF 01 01 01 00 00 00 00 FD //Setting failed

6 Checksum and Calculation

Check = (Invert (byte 1+byte 2+.....+byte 7)) + 1

The reference routine is as follows:

/******

* Function name: unsigned uchar FucCheckSum(uchar *i,uchar ln)

* Function description: Sum check (take the sum of 1\2\3\4\5\6\7 of the sending and receiving protocol to be reversed +1)

* Function description: Add element 1 of the array to the penultimate element and take the inverse +1 (the number of elements must be greater than 2)

```

unsigned char FucCheckSum(unsigned char *i,unsigned char ln)
{
    unsigned char j,tempq=0;
    i+=1;
    for(j=0;j<(ln-2);j++)
    {
        tempq+=*i;
        i++;
    }
    tempq=(~tempq)+1;
    return(tempq);
}
    
```

7 Application field

It can be used for the complete development of household gas leak alarms and household combustible gas detection.

8 Precautions

1. Situations that must be avoided

1.1 Exposure to volatile silicon compound vapor

The module should avoid exposure to silicone adhesive, hair spray, silicone rubber, putty or other places where volatile silicone compounds exist. Otherwise, the sensitivity of the module will decrease or even no response.

1.2 Highly corrosive environment

The module is exposed to high-concentration corrosive gases (such as H₂S, SO_x, Cl₂, HCl, etc.), which will cause corrosion or damage to the sensor heating materials and sensor leads in the module, and cause irreversible deterioration of the performance of sensitive materials. Change, which in turn affects the performance and accuracy of the module.

1.3 Exposure to water

Splashing or immersing the sensor in the module into water will cause the sensor's sensitivity characteristics to decrease, which will affect the measurement accuracy of the module.

1.4 Freezing

The icing on the surface of the sensor's sensitive material of the module will cause the sensitive layer to break and lose its sensitivity.

2. Situations to avoid as much as possible

2.1 Condensate

Under indoor use conditions, slight condensation will have a slight impact on the performance of the sensor in the module. However, if water condenses on the surface of the sensitive layer and keeps it for a period of time, the sensor characteristics in the module will decrease and the measurement error of the module will increase.

2.2 Being in a high-concentration gas

Regardless of whether the module is energized or not, long-term placement in high-concentration gas will affect the sensor characteristics in the module. If the lighter gas is sprayed directly to the sensor in the module, it will cause great damage to the sensor in the module and cause the sensitivity of the module to decrease.

2.3 Long-term storage

If the module is stored for a long time without power on, the resistance of the sensor will have a reversible drift. This drift is related to the storage environment. Modules should be stored in sealed bags that do not contain volatile silicon compounds. Modules that have been stored for a long period of time need to be energized for a longer period of time to stabilize before use. The storage time and the corresponding aging time are recommended as follows:

Storage time	Recommended aging time
Less than 1 month	Not less than 48 hours
1-6 months	Not less than 72 hours
More than 6 months	Not less than 168 hours

Revision history

Version	Date	Description	Issued by
1.0	2020-9-14	Initial version	Ebyte

About us

Technical support: support@cdebyte.com

Documents and RF Setting download link: www.ebyte.com

Thank you for using Ebyte products! Please contact us with any questions or suggestions: info@cdebyte.com

Fax: 028-64146160 ext. 821

Web: www.ebyte.com

Address: Building B5, Mould Industrial Park, 199# Xiqu Ave, West High-tech Zone, Chengdu, 611731, Sichuan, China

 **Chengdu Ebyte Electronic Technology Co.,Ltd.**