

APM10 Product Data Sheet

Laser type particulate matter sensor

- Accurate measurement based on laser scattering principle
The smallest measurable particle size is $0.3\ \mu m$
- Self-calibration technology
- Digital output
- Fully metal shell, stronger anti-EMC ability
- Size only $49 \times 31.5 \times 10.8 mm$

Summary

APM10 is a digital particulate matter sensor based on laser scattering principle. It can detect particulate matter in real time. APM10 detects particle with size ranges from $0.3\ \mu m$ to $10\ \mu m$. It also provides a variety of different digital output interfaces and has turn-on self-calibration function as well as good stability, small size, easy to be integrated.

Application

APM10 can be used in wide range of application scenario , suitable for air purifiers, fresh air system, air quality monitoring equipment, air conditioner etc.



Figure 1. APM10

1. Working principle

APM10 consist of a laser emission element and a light detection element. Two elements are cross placed inside the sensor. As shown in Figure 2, the light detection element collects scattered light intensity in real time. When the air flows through the sensor, the particles inside the sensor cause laser scattering. The light detection element detects changes of the scattered light intensity. The microprocessor calculates the particle size and the number of different particle size per unit volume according to MIE theory by MCU after signal amplification by AFE.

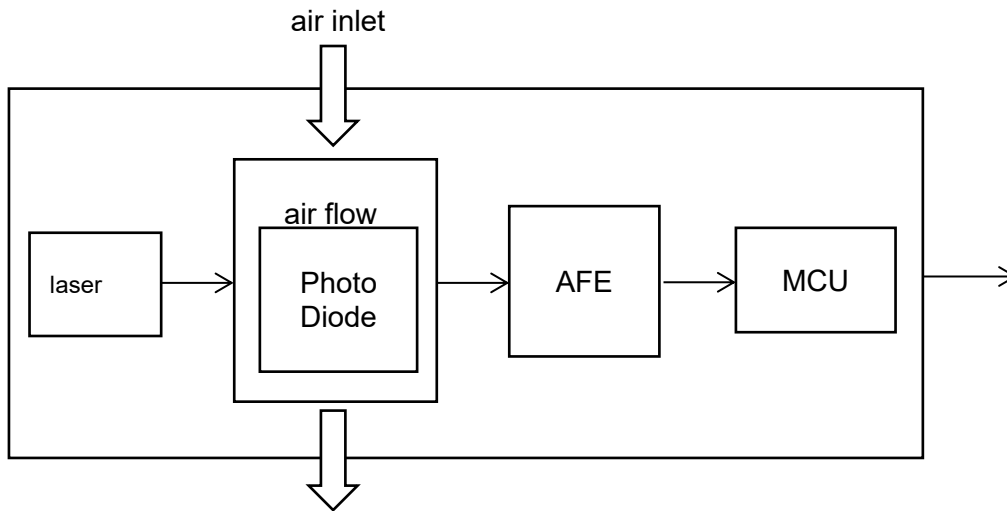

Figure 2. Sensor working principle

2. Parameters

Parameters	Minimum	Typical	Maximum	Unit
Particle size	0.3	2.5	10	μm
Particle concentration	0	-	1000	$\mu g/m^3$
Accuracy ¹	$\pm 15\mu g/m^3$ (0~100 $\mu g/m^3$) $\pm 15\%M.V.$ (100~1000 $\mu g/m^3$)			-
Supply voltage	4.75	5	5.25	V
Operating current	-	50	100	mA
Data update period	1			sec
Life time ²	>3			year
Size	49×31.5×10.8			mm
Operating temperature	-10	25	50	°C
Storage temperature	-30	25	70	°C

Table 1. Sensor characteristics

¹Test conditions: 25±2°C, 50±10%RH, TSI8530, cigarettes

²Depending on the operating environment

User Guide

1. Interface definition and communication protocol

1.1 APM10 pin assignment

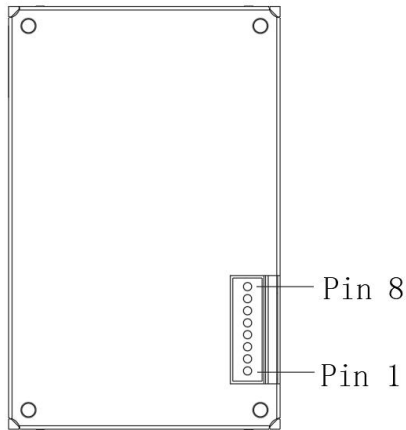

Pin 1	VCC	Power supply
Pin 2	GND	Power ground
Pin 3	SET	0: I ² C; 1 or float:UART
Pin 4	RX/SDA	UART RX/ I ² C SDA
Pin 5	TX/SCL	UART TX/ I ² C SCL
Pin 6	NC	-
Pin 7	NC	-
Pin 8	PWM	PWM output

Figure 3. Communication interface

Table 2. Pin definition

1.2 Interface

SDA and SCL pins should be pull up with external resistor (2kΩ~10kΩ) to VCC.

1.3 I²C Communication Protocol

1.3.1 Start measurement: 10 00 10 05 00 F6

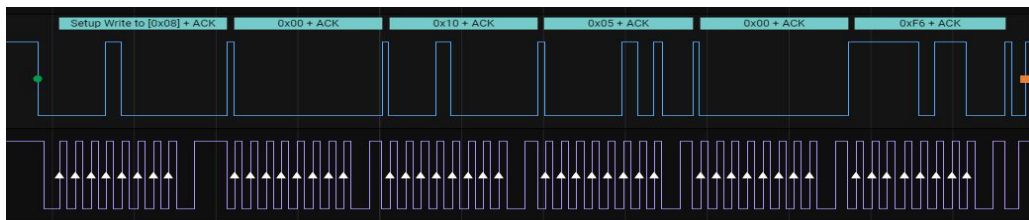

1.3.2 Stop measurement: 10 01 04

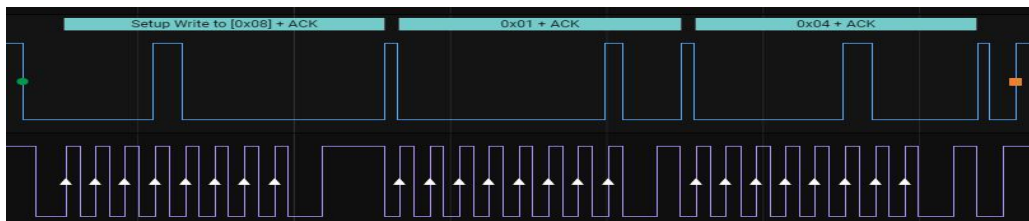

1.3.3 Read the data: 10 03 00 11 Data 0_H Data 0_L Data 0_CRC.....

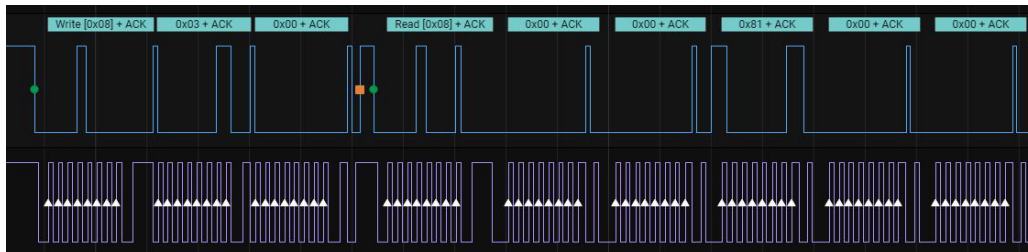

Read 30 bytes of valid data in the following format:

Bytes	Data type	description
0~2	16-digit data, high byte in front, low byte follows, after every two bytes there is a check byte	Reserved
3~5		PM2.5 concentration (standard particulate matter) unit: $\mu g/m^3$
6~8		Reserved
9~11		Reserved
12~14		Reserved
15~17		Reserved
18~20		Reserved
21~23		Reserved
24~26		Reserved
27~29		Reserved

Table 3. Data Format

CRC code:

```

//*****
// Function name: Calc_CRC8
// Function: CRC8 calculation, initial value: 0xFF, polynomial:
//0x31 (x8 + x5 + x4 + 1)
// Parameter: u8*dat: needs to verify the first address of the
//data; u8 Num: CRC verifies the data length
// Return: Check value calculated by crc:
//*****
unsigned char Calc_CRC8(unsigned char *data, unsigned char Num)
{
    unsigned char bit,byte,crc=0xFF;

    for(byte=0; byte<Num; byte++)
    {
        crc^=(data[byte]);
        for(bit=8;bit>0;--bit)
        {
            if(crc&0x80)
                crc=(crc<<1)^0x31;
            else
                crc=(crc<<1);
        }
    }
    return crc;
}
    
```

1.4 UART communication protocol

1.4.1 Serial communication settings

Data domain	Parameters
Baud rate	1200
Data bit	8 bit
Stop bit	1 bit
Parity	None

Table 4. Serial port communication settings

1.4.2 Serial protocol format

Frame head	Fixed code	Length (1-byte)	Command (1 bytes)	Data (n bytes)	Check
FE	A5	XX	XX	XX	CS

Table 5. Serial port protocol format

Protocol Domain	Detailed description
Frame head	Frame head: fixed to FE
Fixed code	sensor category, and the PM2.5 sensor is fixed to A5
Length	Frame-byte-length, which is data-length only
Command code	Operation instruction code
Data	Read or written data, of variable length
Checksum	Checksum = fixed code + length + command code + data

Table 6. serial protocol format

1.4.3 Serial port protocol command table

Function name	Command word
Read the PM2.5 measurements	0x00
Read the PM1.0, PM2.5, PM10 measurements	0x01

Table 7. Serial port protocol command code table

Read the PM2.5 measurement result

Send	FE A5 00 00 A5
Response	FE A5 02 00 DF1 DF2 [CS]
Description	PM2.5 meas. value = DF1×256 + DF2 (unit: $\mu\text{g}/\text{m}^3$)

Table 8. Read the P M2.5 measurement result

Read the PM1.0, PM2.5, PM10 measurement result

Send	FE A5 00 01 A6
Response	FE A5 02 00 DF11 DF12 DF21 DF22 DF31 DF32 [CS]
Description	PM2.5 Meas. Value = DF21×256 + DF22 (Unit: $\mu g/m^3$)

Table 9. Read the PM1.0, P M2.5 and PM10 measurement result

PWM output

PWM transmission (high level effective)	
Measurement range: 0~1000 $\mu g/m^3$	
PM2.5 concentration output	0~1000 $\mu g/m^3$
Cycle	1000ms±5%
High-level output at the cycle start section	200 μs (Theoretical value)
Central cycle	1000ms±5%
The end of the cycle section of the low-level transmission	200 μs (Theoretical value)
PM 2.5 concentration values obtained by PWM: $P(\mu g/m^3) = 1000 \times (TH)/(TH + TL)$	
P ($\mu g/m^3$) is the calculated PM2.5 concentration value in $\mu g/m^3$ TH is the time of output to high levels in one output cycle TL is the time output at a low level	

Table 10.PWM output

Note: The values calculated by PWM represent only PM2.5

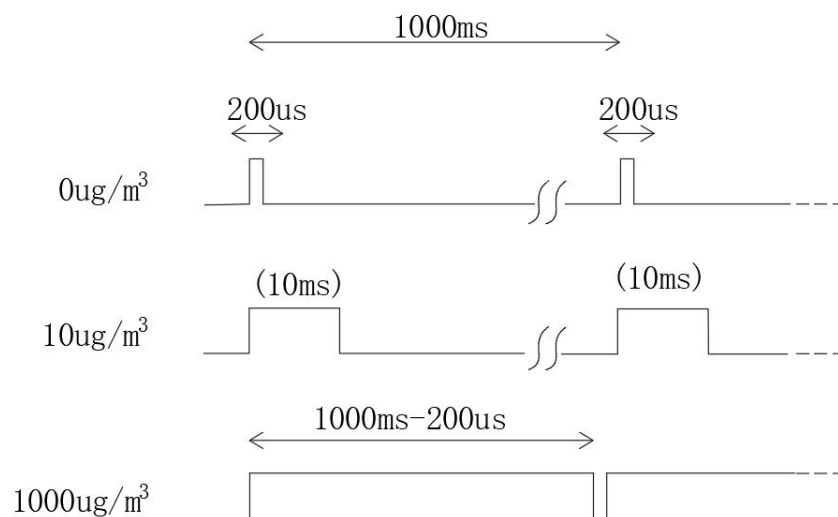

Figure 4. PWM output timing diagram

2. Dimensions

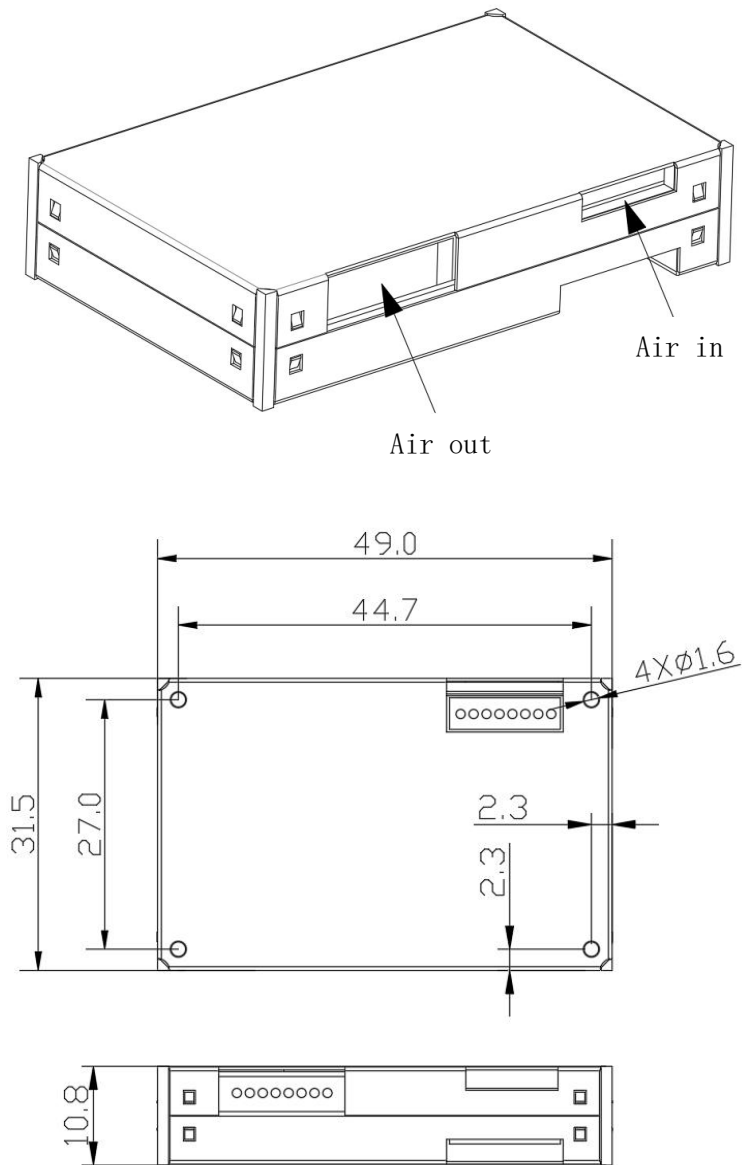

Figure 5. Dimension (unit: mm)

3. Packaging

APM10 is packed in a plastic tray with 25 sensors per tray as shown in Figure 6.

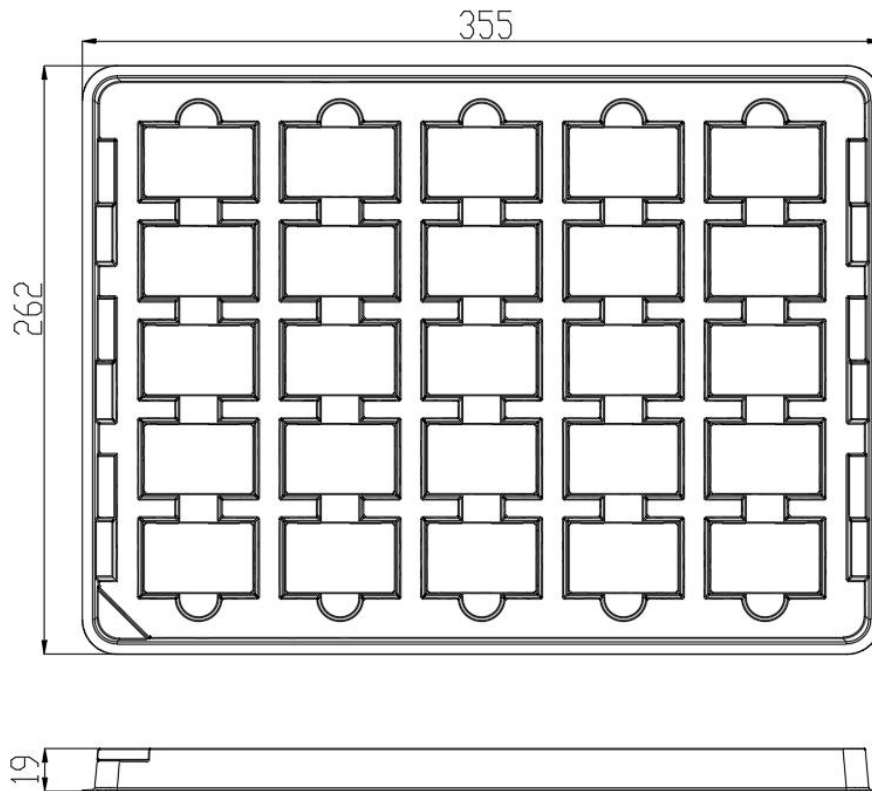

Figure 6. Size of plastic tray (unit: mm)

A single sensor weighs around 22g; one tray with 25 sensors weighs around 550g.

4. Precautions

- 4.1 Since the metal shell of the sensor is connected to the internal power supply, do not connect the sensor shell to external circuits or other instrument shell.
- 4.2 The plane of air inlet and outlet shall be closely attached to the air holes to connect the inner wall and the outside, and that is the best installation method. There shall be no material over and around the air outlet within 2 cm.
There shall be air isolation between air inlet and air outlet to avoid air returning directly from the air outlet to the air.
- 4.3 The size of equipment inlet and outlet hole shall not be smaller than the size of sensor inlet hole.
- 4.4 When used for purifier, do not place the sensor directly into the purifier. A separate space shall be designed to place the sensor to isolate the sensor from the purifier's own air channel.
- 4.5 4.5 The installation position of the sensor should be 20 cm above the ground, otherwise there may be large particles such as dust, floating material or fluff causing failure of fan failure. Appropriate pre-filter process is highly recommended.
- 4.6 Do not disassemble the sensor, in case of irreversible damage.
- 4.7 Default data of this sensor has been tested and all in good consistency. Do not take the third-party testing instrument or data as the comparison standard. If the user wants the measurement data to be consistent with third-party testing equipment, the data can be fitted and calibrated according to the actual measurement results.
- 4.8 This sensor is suitable for normal indoor environment, if use in the following environment, the sensor's data consistency may reduce due to excessive dust accumulation, oil accumulation or water entering:
 - a) Dust concentration greater than $300\mu\text{g}/\text{m}^3$ in 6 month one year, or dust concentration greater than $500\mu\text{g}/\text{m}^3$ in 2 month one year
 - b) Lampblack environment
 - c) High water fog environment
 - d) Outdoor

Warning

Personal injury

Do not apply this product to safety protection devices or emergency stop equipment, and any other applications that may cause personal injury due to the product's failure. Do not use this product unless there is a special purpose or use authorization. Refer to the product data sheet and application guide before installing, handling, using or maintaining the product. Failure to follow this recommendation may result in death and serious personal injury.

If the buyer intends to purchase or use Aosong's products without obtaining any application licenses and authorizations, the buyer will bear all the compensation for personal injury and death arising therefrom, and relieve any possible claims against Aosong's managers, employees, affiliated subsidiaries and agents, distributors, etc., including: various costs, compensation fees, attorney fees and so on.

ESD protection

Due to the inherent design of the element, leading to its sensitivity for static electricity. To prevent static import injury and not reduce product performance, please take necessary antistatic measures when applying this product.

Quality assurance

The company provides the quality guarantee of 12 months (calculated from the date of shipment) to direct purchasers of its products, based on the technical specifications in the product data manual published by Aosong. If the product is proved to be defective during the warranty period, the company will provide free repair or replacement. Users need to satisfy the following conditions:

- Notify our company in writing within 14 days after the defect is found.
- The defect of this product will help to find out the deficiency in design, material and technology of our product.
- The product should be sent back to our company at the buyer's expense.
- The product should be within the warranty period.

The company is only responsible for products that are defective when used in applications that meet the technical conditions of the product. The company does not make any guarantees or written statements about the application of its products in those special applications. At the same time, the company does not make any promises about the reliability of its products when applied to products or circuits.

This manual may be changed at any time without notice.

Copyright ©2021, ASAIR ®