

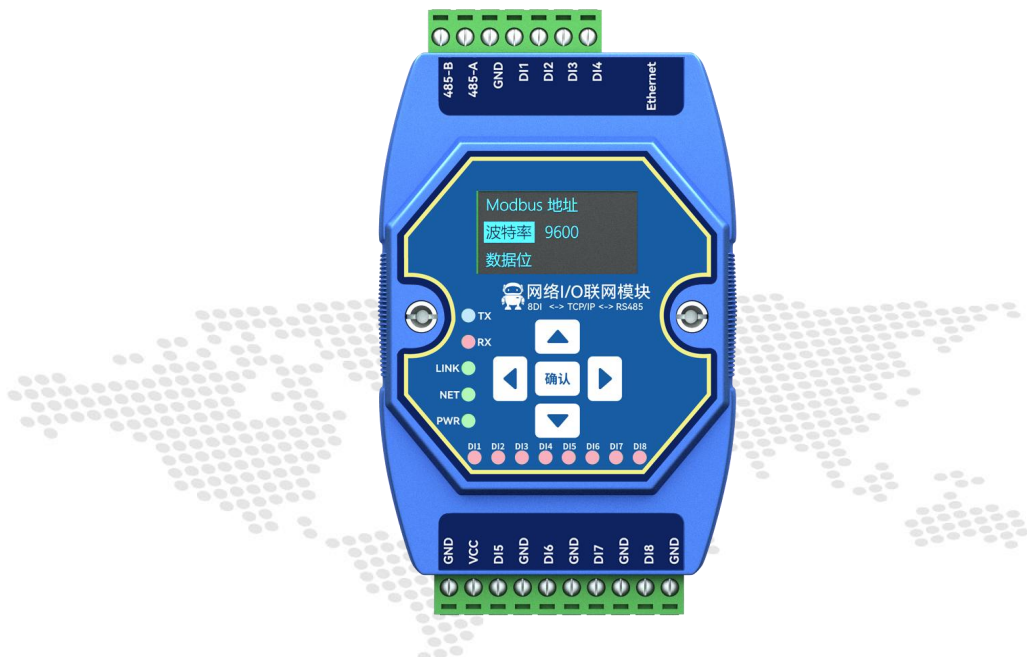

Chengdu Ebyte Electronic Technology Co.,Ltd

Wireless Modem

User Manual



ME31-AXXX8000

I/O Networking Module

All rights to interpret and modify this manual belong to
Chengdu Ebyte Electronic Technology Co., Ltd.

Contents

1. Product overview	1
1.1 Introduction	1
1.2 Features	1
1.3 Application typology diagram	2
2. Quick start	3
2.1 Devices required	3
2.2 Device connection	3
2.2.1 DI switch input connection	4
2.2.2 Simple use	4
2.3 Parameter configuration	4
2.4 Control test	5
2.4.1 Modbus TCP Control	5
2.4.2 Modbus RTU Control	6
3 Technical indicator	7
3.1 Specification and parameter	7
3.2 Device default parameter	7
3.3 Dimensions	8
3.4 Ports and indicators	9
4 Product function introduction	11
4.1 DI input	11
4.1.1 Switch input DI acquisition	11
4.1.2 Input filtering	11
4.2 Modbus gateway	11
4.2.1 Modbus TCP/RTU Protocol Conversion	11
4.2.2 Modbus address filtering	11
4.2.3 Modbus TCP protocol data frame description	12
4.2.4 Modbus RTU protocol data frame description	12
4.3 Active upload	12
4.4 Custom Module Information	13
4.4.1 Modbus address	13
4.4.2 Module name	13
4.4.3 Network parameter	13
4.4.4 UART parameter	13
4.5 OLED display and parameter configuration	14
4.5.1 Information display interface	14
4.5.2 Device parameter display interface	14
4.5.3 Device parameter configuration interface	15
4.5.4 Screen sleep	15
4.6 MODBUS parameter setting	16
4.6.1 DI register list	16
4.6.2 Module related register	16
4.6.3 Network related register	17
4.6.4 Modbus command operation	18

5 Host computer	21
5.1 Acquisition and control	21
5.2 Parameter Configuration Interface	22
Revision history	24

1. Product overview

1.1 Introduction

ME31-AXXX8000 is equipped with 8 dry contact input detection, supports Modbus TCP protocol or Modbus RTU protocol for acquisition and control and can be used as a simple Modbus gateway (automatically send commands with non-local Modbus addresses through the serial port/network port).



1.2 Features

- Good for standard Modbus RTU protocol and MODBUS TCP protocol;
- Work with various configuration software/PLC/touch screen;
- RS485 acquisition control I/O;
- RJ45 acquisition control I/O, support 4 channel master access;
- Support OLED display screen to display status information, and device parameters can be configured through buttons;
- 8-channel switch input DI (dry node) ;
- Support custom Modbus address settings;
- Support 8 common baud rate configurations ;
- DHCP and static IP;
- DNS function, domain name analysis;
- Support Modbus gateway;

1.3 Application typology diagram

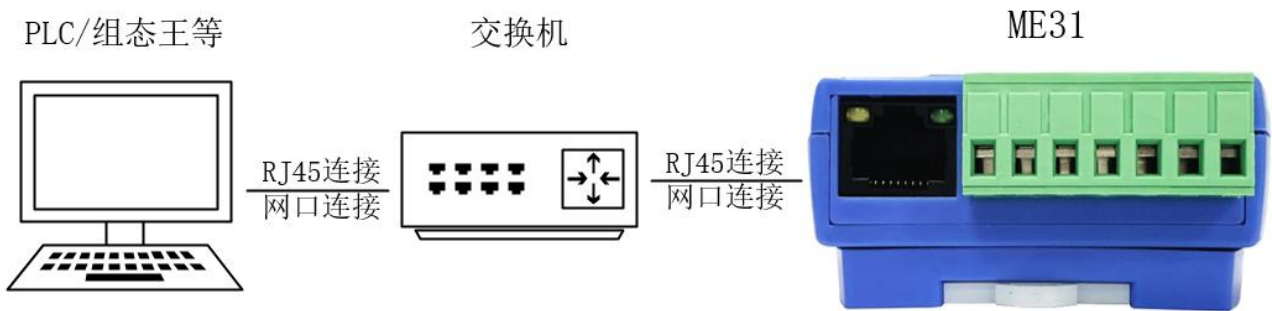

Network port application topology







Serial port application topology

2. Quick start

Note: The test need to carry out with factory parameter.

2.1 Devices required

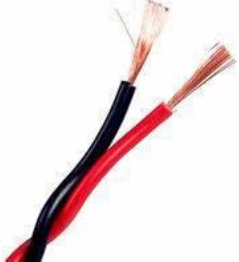
		
ME31-AXXX8000	12V SMPS	USB to RS485
		
Computer	RJ45 Cable	More cables

2.2 Device connection

2.2.1 RS485 connection

RS485接线图

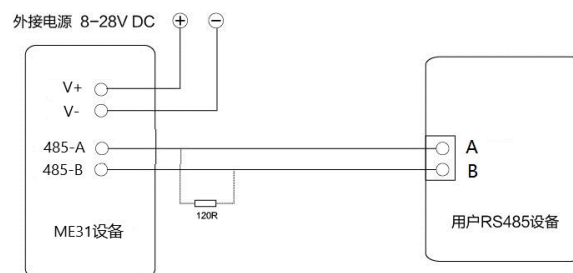

Note: When the 485 bus high frequency signal is transmitted, the signal wavelength is shorter than the transmission line, and the signal will form a reflected wave at the end of the transmission line, which will interfere with the

original signal. Therefore, a terminal resistance must be added at the end of the transmission line to prevent the signal from being reflected after reaching the end of the transmission line. The terminal resistance should be the same as the impedance of the communication cable, with a typical value of 120 ohms. Its function is to match the bus impedance and improve the anti-interference and reliability of data communication.

2.2.1 DI switch input connection

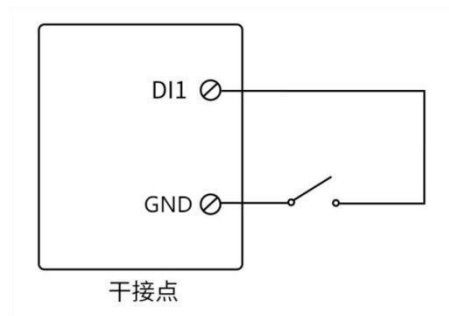

2.2.2 Simple use

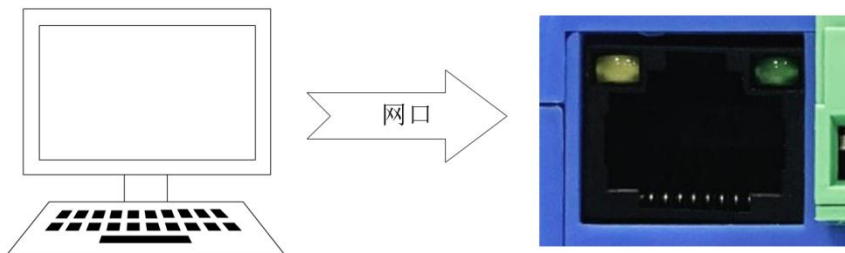

Wiring: The computer is connected to the RS485 interface of ME31-AXXX8000 through USB to RS485, A is connected to A, B is connected to B.

Networking: Insert the network cable into the RJ45 port and connect to the PC.

Power supply: Use DC-12V switching power supply (DC 8~28V) to supply power to ME31-AXXX8000.

2.3 Parameter configuration

Step 1: Modify the IP address of the computer to be consistent with the device. Here it is modified to 192.168.3.100 to ensure the same network segment as the device and that the IP is different. Please turn off the firewall and try again if the step failed;

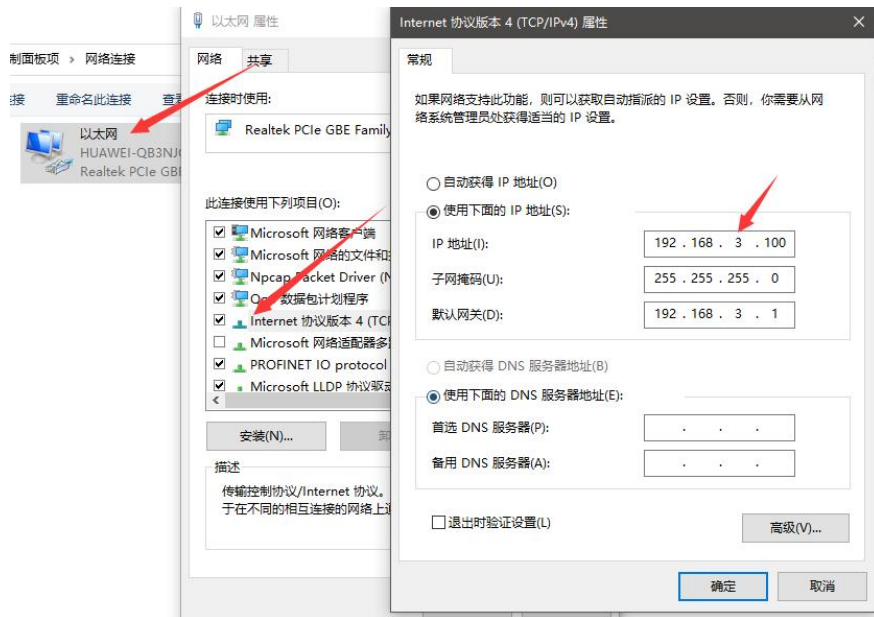

Step 2: Open the network assistant, select the TCP client, enter the remote host IP 192.168.3.7 (default parameters), enter the port number 502 (default parameters), and select HEX to send.



2.4 Control test

2.4.1 Modbus TCP Control

Use network assistant to control ME31-AXXX8000, first channel DO output.



To test other function according to below table

Function (function code)	Command
Read all DI state (0x02)	01 00 00 00 00 06 01 02 00 00 00 08

2.4.2 Modbus RTU Control

Use network assistant to control ME31-AXXX8000, first channel DO output.

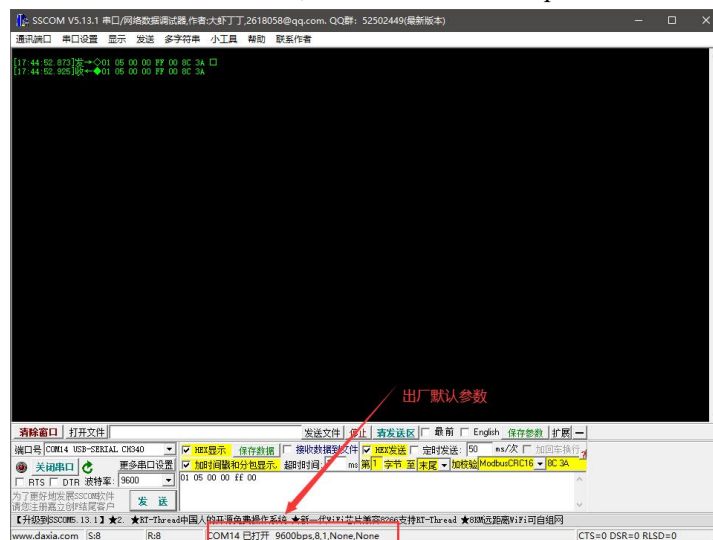

To test other function according to below table

Function (function code)	Command
Read all DI state (0x02)	01 02 00 00 00 08 79 CC

3 Technical indicator

3.1 Specification and parameter

Category	Name	Parameter
Power supply	Operating voltage	DC8 ~ 28V
	Power indicator	Blue LED indicator
Serial port	Communication interface	RJ45、RS485
	Baud rate	9600bps (can be defined by user)
	Communication protocol	Standard Modbus TCP,Modbus RTU
MODBUS	Device address	Modify via Modbus command and computer
DI input	DI channels	8 channel
	Input type	Default dry node
	Acquisition frequency	1 kHz
	Input indicator	OLED display, red LED
Others	Product size	121mm * 72mm * 34mm
	Product weight	135 ±5 g
	Working temperature and humidity	-40 ~ +85°C、5% ~ 95%RH (no condensation)
	Storage temperature and humidity	-40 ~ +105°C、5% ~ 95%RH (no condensation)
	Installation	Din rail installation

3.2 Device default parameter

Category	Name	Parameter
Ethernet parameter	Working mode	TCP server (Max 4 channel client access)
	Local IP	192.168.3.7
	Local port	502
	Subnet mask	255.255.255.0
	Gateway address	192.168.3.1

	DHCP	Off
	Local MAC	Depending on chip (fixed)
	Target IP	192.168.3.3
	Target port	502
	DNS server	114.114.114.114
	Active upload	Off
UART parameter	Baud rate	9600bps (8 type)
	Check method	None (default)、Odd、Even
	Data bit	8
	Stop bit	1
MODBUS parameter	Modbus master slave	Slave
	Address	1

3.3 Dimensions

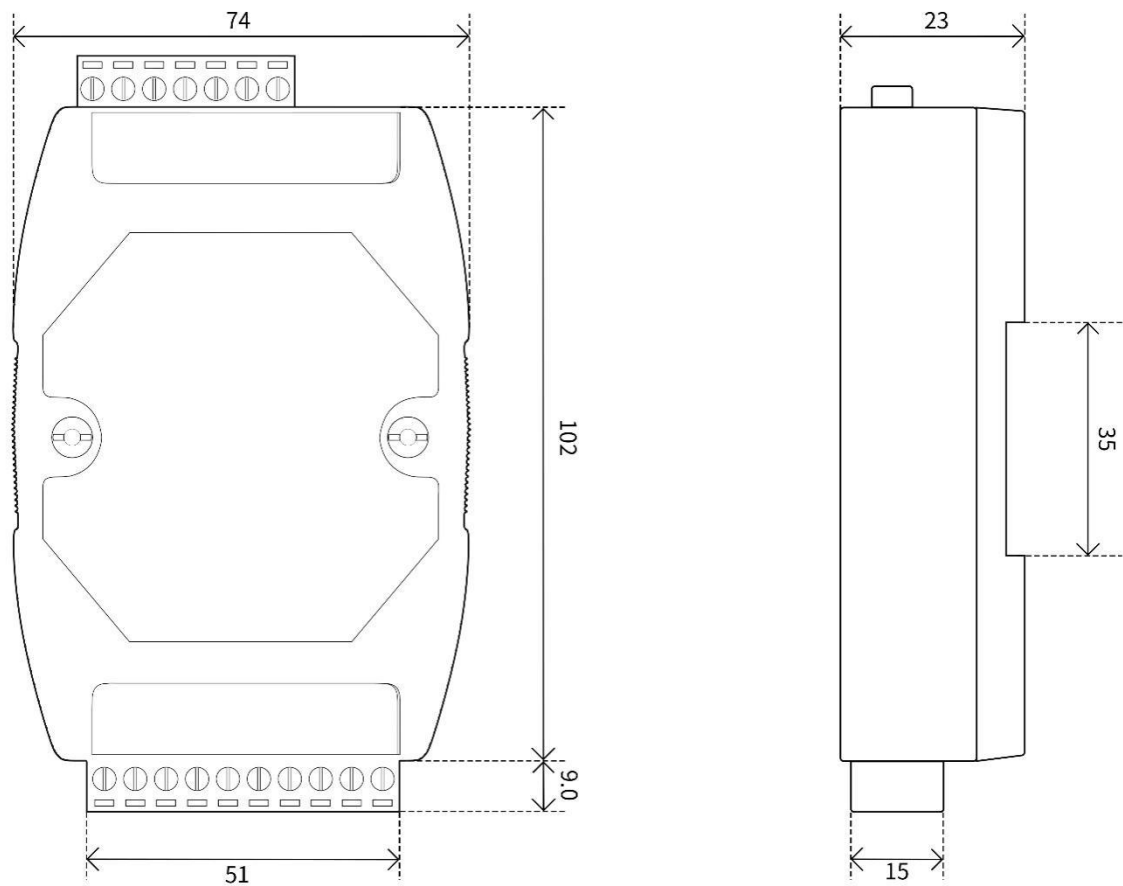

3.4 Ports and indicators



No.	Sticker	Remarks
1	TX (LED)	UART TX data
2	RX (LED)	UART RX data
3	LINK (LED)	Network link
4	NET (LED)	Network data TX and RX
5	PWR (LED)	Power input
6	DI1 (LED)	Switch input indicator of channel 1
7	DI2 (LED)	Switch input indicator of channel 2
8	DI3 (LED)	Switch input indicator of channel 3
9	DI4 (LED)	Switch input indicator of channel 4
10	DI5 (LED)	Switch input indicator of channel 5
11	DI6 (LED)	Switch input indicator of channel 6
12	DI7 (LED)	Switch input indicator of channel 7
13	DI8 (LED)	Switch input indicator of channel 8
14	GND	Negative pole of power input terminal, DC 8V~28V, 5.08mm phoenix terminal
15	VCC	Positive pole of power input terminal, DC 8V~28V, 5.08mm phoenix terminal
16	DI5	Switch input channel 5, support dry contact access , 5.08mm phoenix terminal

17	GND	Channel 5 switch input ground, 5.08mm phoenix terminal
18	DI6	Switch input channel 6, support dry contact access , 5.08mm phoenix terminal
19	GND	Channel 6 switch input ground, 5.08mm phoenix terminal
20	DI7	Switch input channel 7, support dry contact access , 5.08mm phoenix terminal
21	GND	Channel 7 switch input ground, 5.08mm phoenix terminal
22	DI8	Switch input channel 8, support dry contact access , 5.08mm phoenix terminal
23	GND	Channel 8 switch input ground, 5.08mm phoenix terminal
24	Ethernet	Standard RJ45 interface
25	DI4	Switch input channel 4, support dry contact access , 5.08mm phoenix terminal
26	DI3	Switch input channel 3, support dry contact access , 5.08mm phoenix terminal
27	DI2	Switch input channel 2, support dry contact access , 5.08mm phoenix terminal
28	DI1	Switch input channel 1, support dry contact access , 5.08mm phoenix terminal
29	GND	Channel 1-4 switch input ground, 5.08mm phoenix terminal
30	485-A	A of the RS-485 serial port is connected to the A port of the external device , 5.08mm phoenix terminal
31	485-B	B of the RS-485 serial port is connected to the B port of the external device , 5.08mm phoenix terminal

4 Product function introduction

4.1 DI input

4.1.1 Switch input DI acquisition

Switch input DI measurement level signal or edge pulse signal (rising edge, falling edge). Support dry node collection, support DI counting function, the maximum count is 65535 (the count is automatically cleared if it exceeds 65535).

The switch input DI branch has three trigger modes: rising edge, falling edge and level (default rising edge trigger).

The clearing method supports automatic clearing and manual clearing (default automatic clearing).

4.1.2 Input filtering

When the switch input DI collects the signal, it needs to keep several sampling cycles before confirming. Filter parameters can be set in the range of 1 to 16 (default 6 sampling periods, 6*1kHz).

It can be configured with the host computer through instructions.

4.2 Modbus gateway

The device can transmit non local Modbus instructions from the network/serial port to the serial port/network, and the local Modbus instructions can be executed directly.

4.2.1 Modbus TCP/RTU Protocol Conversion

After being turned on, the Modbus TCP data on the network side will be converted into Modbus RTU data.

4.2.2 Modbus address filtering

This function can be used in certain host software or configuration screens as the host to access the device serial port, and the gateway function of the device is used. When the slave is on the network side and the Modbus TCP to RTU function is enabled, the presence of multiple slaves on the bus may cause data confusion. At this time, enabling address filtering can ensure that only the specified address can pass through the device; When the parameter is 0, data is transmitted through, and when the parameter is 1-255, data is only transmitted through the set slave address.

4.2.3 Modbus TCP protocol data frame description

TCP frame format:

Transaction ID	Protocol ID	Length	Device Address	Function Code	Data Segment
2 Bit	2 Bit	N+2 Bit	1 Bit	1 Bit	N Bit

- Transaction identification: It can be understood as the serial number of the message. Generally, 1 is added after each communication to distinguish different communication data messages.
- Protocol identifier: 00 00 means Modbus TCP protocol.
- Length: Indicates the next data length, in bytes.

For example: get DI state

01 00	00 00	00 06	01	02	00 00 00 04
Transaction ID	Protocol ID	Length	Device Address	Function Code	Data Segment

4.2.4 Modbus RTU protocol data frame description

RTU frame format:

Device Address	Function Code	Data Segment	Check code CRC
1 Bit	1 Bit	N Bit	2 Bit

For example: get DI state command

01	02	00 00 00 04	79 C9
Device Modbus address	Function Code	Data Segment	CRC check code

4.3 Active upload

The device supports the function of uploading analog input values at fixed time intervals. Setting the value of the corresponding register can control the interval time and whether to upload or not.

The device with digital input will actively upload once after connecting to the server successfully, and then the digital input will be uploaded following the status change, and the device with analog input will report the status of the analog input according to the configuration of the active upload time period (the configuration period is 1-65535).

When set to 0, the upload is closed, and when set to another positive integer value N, the upload is performed at intervals of N seconds.

[Note] The device can only be valid if it is in the client mode configuration. If the register value is non-zero, active uploading is enabled.

4.4 Custom Module Information

4.4.1 Modbus address

The default address of the device is 1, and the address can be modified. The address range is 1-247.

4.4.2 Module name

Users can configure the device name for differentiation according to their own needs. It supports English and digital formats, and the maximum length is 20 bytes.

4.4.3 Network parameter

Unless otherwise specified: The following network-related parameters default to IPV4-related parameters.

- (1) MAC of the device: the user can obtain it by reading the specified register, and this parameter cannot be written.
- (2) IP address: IP address of the device, readable and writable.
- (3) Modbus TCP port: the port number of the device, readable and writable.
- (4) Subnet mask: address mask, readable and writable.
- (5) Gateway address: gateway.
- (6) DHCP: Set the way the device obtains IP, static (0), dynamic (1).
- (7) Target IP: When the device works in client mode, the target IP or domain name of the device connection.
- (8) Target port: When the device works in client mode, the target port to which the device is connected.
- (9) DNS server: When the device is in client mode, it resolves the server domain name.
- (10) Module working mode: switch the working mode of the module. Server: The device is equivalent to a server, waiting for the user's client to connect, and the maximum number of connections is 4. Client: The device actively connects to the target IP and port set by the user.
- (11) Active upload: When the secondary parameter is not 0 and the device is in the client mode, the discrete input state of the device will be uploaded to the server after the initial connection or input changes, and the analog input will be uploaded according to the configured time period.

4.4.4 UART parameter

Parameters for setting serial communication:

Default parameters:

Baud rate: 9600(03);

Data bits: 8bit;

Stop bit: 1bit;

Check digit: NONE(00);

(1) Baud rate:

Baud rate code value table	
0x0000	1200
0x0001	2400
0x0002	4800
0x0003 (default)	9600
0x0004	19200
0x0005	38400
0x0006	57600
0x0007	115200

(2) Check digit:

Check digit	
0x0000(默认)	NONE
0x0001	ODD
0x0002	EVEN

4.5 OLED display and parameter configuration

The display interface includes information display page (DI input status) and parameter setting page (part of parameters).

4.5.1 Information display interface

Including the current input value display page, shortly press the left and right buttons to switch the interface

4.5.2 Device parameter display interface

Press the left or right button to enter the password input interface, complete the correct password input, and display the device parameter information interface (password interface: default password: 0000; short press the middle verification password, left and right buttons to switch password bits, up and down buttons to switch current bit values, a total of 4 digits of the password, with each input range of 0-9 digits):

The parameter setting interface from top to bottom is

1. Modbus address;
2. Baud rate;

3. Data bits;
4. Check digit;
5. Stop bit;
6. Local port
7. Local IP address
8. Network mode
9. Gateway
10. Subnet mask
11. DNS
12. MAC address
13. DHCP
14. Target IP
15. Target port
16. Modbus TCP/RTU protocol conversion
17. Active upload
18. Modbus address filtering

4.5.3 Device parameter configuration interface

Long press the confirm button to enter the password input interface, complete the correct password input, and enter the configuration interface (password interface: default password: 0000; short press the middle to verify the password, left and right buttons to switch password bits, up and down buttons to switch current bit values, a total of 4 digits of password, with each digit entering a range of 0-9 numbers).

Select the setting option, enter the parameter configuration page, and briefly press the up and down keys to switch between the setting options;

Select the setting item, short press to confirm or right-click, and the cursor for the setting item represents the selected item and enters the setting item;

Adjust parameter values: After selecting the setting option, the up and down keys can change the numerical value or optional values; Press the left and right buttons to move the cursor within the parameter item;

Confirm parameter values: After adjusting the parameter values, press the confirm button to exit the current setting.

Save parameter settings and restart: After setting the parameters, move the cursor to save and restart, then short press the confirm button to enter the confirm save and restart state. Short press the confirm button (press other buttons to exit the confirmation state) to save the parameters and restart the device.

Exit without saving parameters: move the cursor to Exit, and then press the OK key briefly to enter the confirmed Exit status. Press the OK key briefly (press other keys to exit the confirmed status) to exit the parameter configuration interface without saving parameters.

Among them, the data bits and stop bits cannot be set. After enabling DHCP mode, the local IP address, gateway, and subnet mask cannot be configured and only assigned by the router;

4.5.4 Screen sleep

The device screen has a sleep function, which is turned off by default and can be set to turn on in the configuration

interface.

In any interface, after 180 seconds of no button operation, the screen will enter sleep mode, and the interface will display Xiaoyi Robot. Press any button to exit sleep mode.

When the screen is dormant, the efficiency of device program operation will be improved.

4.6 MODBUS parameter setting

4.6.1 DI register list

Register function	Register address	Register type	Quantity	Operation	Data Range/Remarks	Related function codes
DI state	0x0000	Discrete input	8	R	Enter the port state	R: 0x02
DI filter parameters	0x04B1	Holding register	1	RW	Digital filter parameter, the range is 1~16, the smaller the number, the more sensitive, the larger the more stable, the default is 6	R: 0x03 W: 0x06、0x10
DI pulse count value	0x09DF	Holding register	8	RW	Enter count value	R: 0x03 W: 0x06、0x10
DI clear way	0x0A43	Holding register	8	RW	0x0000 auto clear 0x0001 manual clear	R: 0x03 W: 0x06、0x10
DI manual clear signal	0xAA7	Holding register	8	RW	The clearing method is manual, and the register writes 1 to clear the count value	R: 0x03 W: 0x06、0x10
DI count way	0x0B0C	Holding register	8	RW	Set DI count way	R: 0x03 W: 0x06、0x10

4.6.2 Module related register

Register function	Register address	Register type	Quantity	Operation	Data Range/Remarks	Related function codes
Module address	0x07E8	Holding register	1	RW	Modbus address, 1~247 configurable	R: 0x03 W: 0x06
Module model	0x07D0	Holding register	12	R	Get current model	R: 0x03
Firmware version	0x07DC	Holding register	1	R	Get firmware version	R: 0x03

Module name	0x07DE	Holding register	10	RW	Define module name	R: 0x03 W: 0x10
Module reset	0x07EA	Holding register	1	W	Enter any value to reset	W: 0x06
Restore factory parameter	0x07E9	Holding register	1	W	Enter any value to restore	W: 0x06
Serial baud rate	0x0834	Holding register	1	RW	See the baud rate code table, Default 9600 (0x0003)	R: 0x03 W: 0x06、0x10
Serial check digit	0x0836	Holding register	1	RW	0x0000 none (default) 0x0001 odd 0x0002 even	R: 0x03 W: 0x06、0x10

4.6.3 Network related register

Register function	Register address	Register type	Quantity	Operation	Data Range/Remarks	Related function codes
Module MAC address	0x0898	Holding register	3	R	Device MAC parameter	R: 0x03
Local IP address	0x089B	Holding register	2	RW	Default: 192.168.3.7	R: 0x03 W: 0x06、0x10
Local port	0x089D	Holding register	1	RW	1~65535, default: 502	R: 0x03 W: 0x06、0x10
Subnet mask	0x089E	Holding register	2	RW	Default: 255.255.255.0	R: 0x03 W: 0x06、0x10
Gateway address	0x08A0	Holding register	2	RW	Default: 192.168.3.1	R: 0x03 W: 0x06、0x10
DHCP mode configuration	0x08A2	Holding register	1	RW	0x0000 static IP (default) 0x0001 automatically get IP	R: 0x03 W: 0x06、0x10
Target IP/Domain Name	0x08A3	Holding register	64	RW	Store in strings IP/Domain Name Default IP: 192.168.3.3	R: 0x03 W: 0x06、0x10
Server port	0x08E3	Holding register	1	RW	0-65535, Default 502	R: 0x03 W: 0x06、0x10
DNS server IP address	0x08E4	Holding register	2	RW	Default 8.8.8.8	R: 0x03 W: 0x06、0x10
Module operating mode	0x08E6	Holding register	1	RW	0x0000 server mode 0x0001 client mode	R: 0x03 W: 0x06、0x10
Active upload	0x08E7	Holding register	1	RW	0x0000 prohibited , Other:	R: 0x03 W: 0x06、0x10

					Send in 1~65535s	
MOSBUS TCP/RTU conversion	0x08E8	Holding register	1	RW	0,turn off, 1turn on	R: 0x03 W: 0x06、0x10
MODBUS address filtering	0x08E9	Holding register	1	RW	0: Transparent transmission, 1-255: When non local data is present, check the slave address of the instruction instruction. When it is set to a value, it can be passed through the	R: 0x03 W: 0x06、0x10

4.6.4 Modbus command operation

1. Read coil (DO) status

Use the read coil status (01) function code to read the output coil status, for example:

01	01	00 00	00 04	3D C9
Modbus address	Function code	Register first address	Output coil quantity	CRC check code

After the above command is sent to the device through the 485 bus, the device will return the following values:

01	01	01	01	90 48
Modbus address	Function code	Number of bytes of data	Status data returned	CRC check code

The above returned status data 01 indicates that the output DO1 is turned on.

2. Control coil (DO) status

Support operation of single coil (05), operation of multiple coils (0F) function code operation. Use the 05 command to write a single command, for example:

01	05	00 00	FF 00	8C 3A
Modbus address	Function code	Register first address	On: FF 00 Off: 00 00	CRC check code

After sending the above command to the device through the 485 bus, the device will return the following values:

01	05	00 00	FF 00	8C 3A
Modbus address	Function code	Register first address	Operation method	CRC check code

DO1 coil conduction

Use the 0F function code as the command to write multiple coils, for example:

01	0F	00 00	00 04	01	0F	7E 92
Modbus address	Function code	Starting address	Coil number	Number of bytes of data	Data of control coil	CRC check code

After the above command is sent to the device through the 485 bus, the device will return the following values

01	0F	00 00	00 04	54 08
Modbus address	Function code	Register address	Coil number	CRC check code

All coils are conducted.

3. Read Holding register

Use the 03 function code to read one or more register values, for example:

01	03	05 78	00 01	04 DF
Modbus address	Function code	Register first address	Quantity of register read	CRC check code

After the above command is sent to the device through the 485 bus, the device will return the following values:

01	03	02	00 00	B8 44
Modbus address	Function code	Number of bytes of data	Data returned	CRC check code

The above 00 00 indicates that DO1 is in level output mode.

4. Operate Holding register

Support operation of single register (06), operation of multiple registers (10) function code operation.

Use the 06 function code to write a single Holding register, for example: set the working mode of DO1 to pulse mode

01	06	05 78	00 01	C8 DF
Modbus address	Function code	Register address	Write value	CRC check code

After the above command is sent to the device through the 485 bus, the device will return the following values:

01	06	05 78	00 01	C8 DF
Modbus address	Function code	Register address	Write value	CRC check code

If the modification is successful, the 0x0578 register data is 0x0001, and the pulse output mode is turned on.

Use the 10 function code to write multiple holding register commands, for example: set the working mode of DO1 and DO2 at the same time.

01	10	05 78	00 02	04	00 01 00 01	5A 7D
Modbus address	Function code	Register first address	Register number	Quantity of bytes of written data	Written data	CRC check code

After the above command is sent to the device through the 485 bus, the device will return the following values:

01	10	05 78	00 02	C1 1D
Modbus address	Function code	Register address	Register quantity	CRC check code

If the modification is successful, the values of the two consecutive registers with 0x0578 as the starting address are 0x0001 and 0x0001 respectively to identify DO1 and DO2 to enable pulse output.

5 Host computer

5.1 Acquisition and control

Step 1: Connect the computer to the device

(1) The device can be configured by selecting interfaces (serial/network); If you choose a network port, you need to first select the network card before searching for devices.

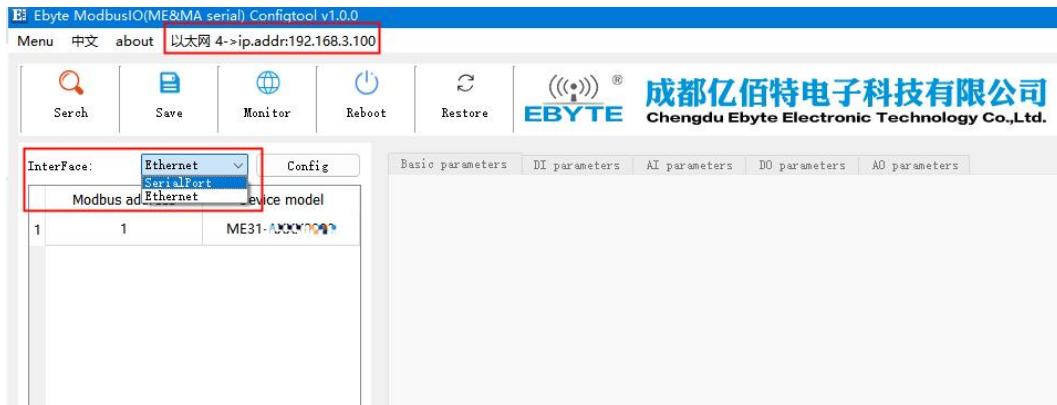

(2) If you select a serial port, you need to select the corresponding serial port number and the same Baud, data bit, stop bit, check bit and address segment search range as the device, and then search.

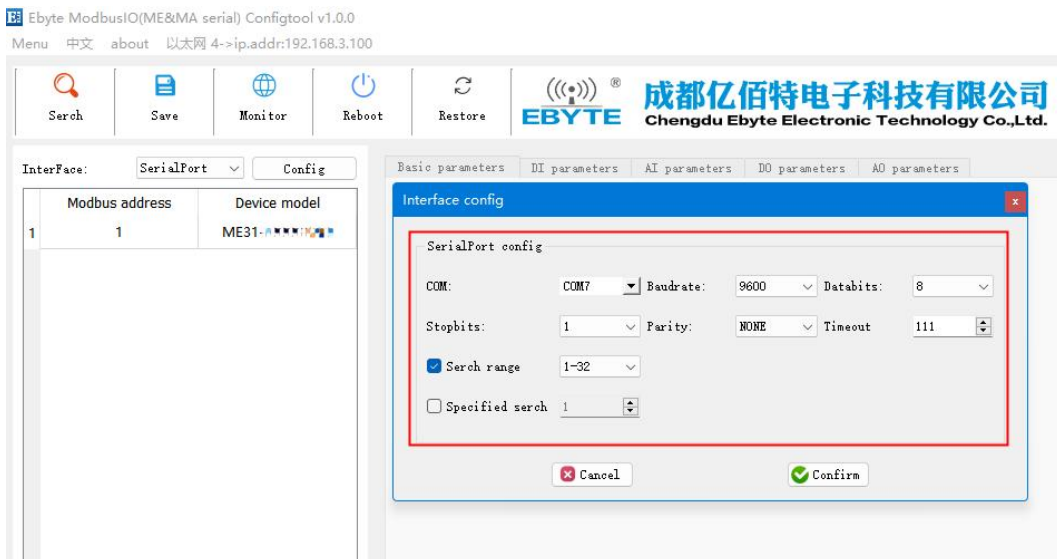

Step 1: Select the right device

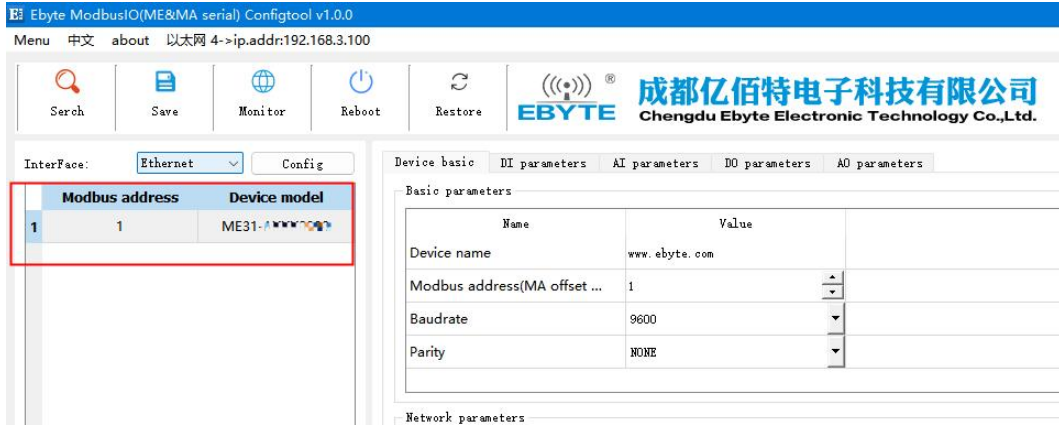

Step 2: Click on the device online to enter IO monitoring. The following is the IO monitoring screen display

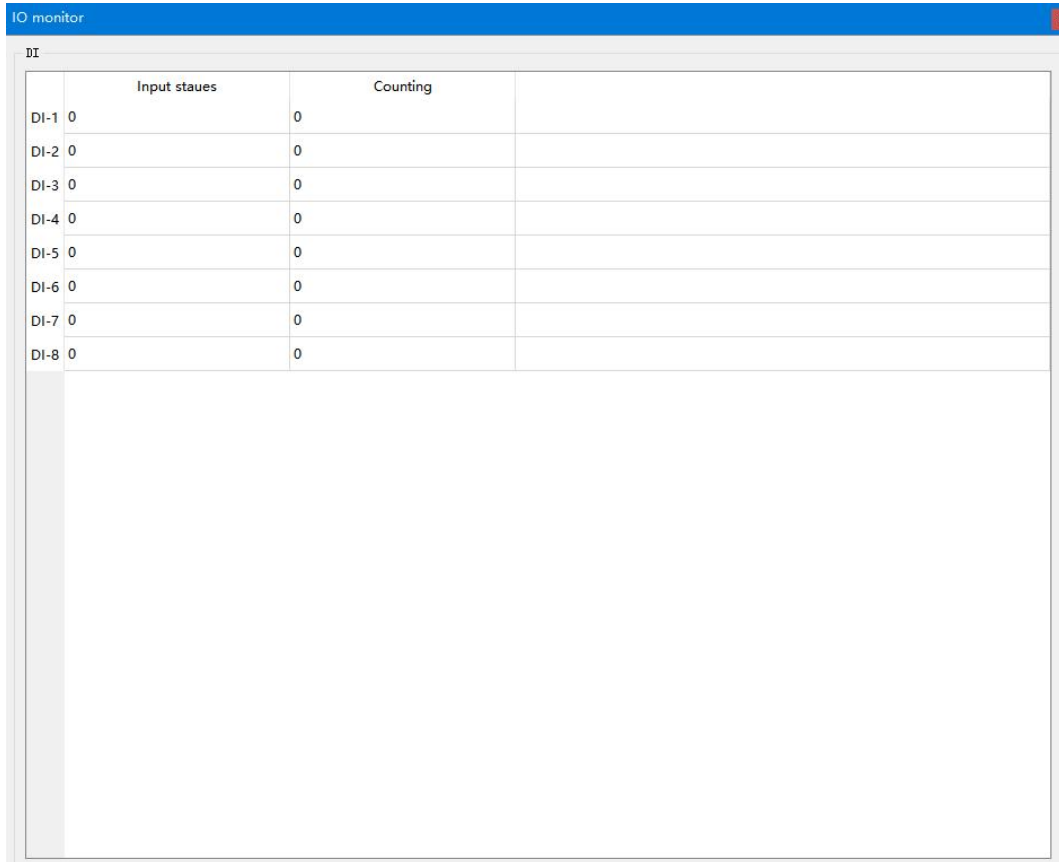

5.2 Parameter Configuration Interface

Step 1: Connect the device according to "Collection and Control"

Step 2: You can configure device parameters, network parameters, DI parameters, AI parameters, DO parameters, and AO parameters (for example, if the device does not have AO function, AO parameters cannot be configured)

Device basic parameters:

Name	Value
Device name	www.ebyte.com
Modbus address(MA offset ...)	1
Baudrate	9600
Parity	NONE

Network parameters:

Name	Value
Local IP	192.168.3.7
ModbusTCP port	502
Submask	255.255.255.0
Gateway	192.168.3.1
DHCP	Disable
Remote ip/domain	192.168.3.3
Remote port	502
DNS server address	114.114.114.114
Network protocol	TCP Client
Auto upload	OS
TCP/RTU translation	Enable
Modbus address filter	0

Log:

Date	Time	Info
2023-07-12	13:51:20.032	Searching
2023-07-12	13:51:20.086	Search for all device.....
2023-07-12	13:51:21.028	Uploading parameters>>MAC address:38-38-26-22-A3-A4
2023-07-12	13:51:21.812	uploading parameters success>>Modbus address:1,device model:ME31-AXXX8000
2023-07-12	13:51:21.813	The search is complete>>A total of1devices were found

Step 3: After configuring the parameters, click to download them. In the log output, you will see a prompt stating that the parameters have been successfully saved. Click to restart the device. After the device restarts, the modified parameters will take effect.

Device basic parameters:

Name	Value
Device name	www.ebyte.com
Modbus address(MA offset ...)	1
Baudrate	9600
Parity	NONE

Network parameters:

Name	Value
Local IP	192.168.3.7
ModbusTCP port	502
Submask	255.255.255.0
Gateway	192.168.3.1
DHCP	Disable
Remote ip/domain	192.168.3.3
Remote port	502
DNS server address	114.114.114.114
Network protocol	TCP Client
Auto upload	OS
TCP/RTU translation	Enable
Modbus address filter	0

Log:

Date	Time	Info
2023-07-12	13:51:21.813	The search is complete>>A total of1devices were found
2023-07-12	13:52:41.052	Saving parameters
2023-07-12	13:52:41.629	Parameters save success
2023-07-12	13:52:48.714	Rebooting
2023-07-12	13:52:48.742	Reboot Success

Revision history

Version	Date	Remarks	Issued by
1.0	2023-06-06	First version	LT

About us

Technical support: support@cdebyte.com

Documents and RF Setting download link: <http://www.cdebyte.com>

Thank you for using Ebyte products! Please contact us with any questions or suggestions: info@cdebyte.com

Phone: +86 028-61399028

Web: <http://www.cdebyte.com>

Address: B5 Mould Park, 199# Xiqu Ave, High-tech District, Sichuan, China

