



Chengdu Ebyte Electronic Technology Co.,Ltd

Wireless Modem

User Manual



【4AI + 4DO】 **MA01 -XACX0440**

All rights to interpret and modify this manual belong to
Chengdu Ebyte Electronic Technology Co., Ltd.

Contents

- Disclaimer 3
- 1. Product Introduction4
 - Features 4
- 2. Quick Start.....5
 - 2.1 Use preparation5
 - 2.2 Equipment wiring5
 - 2.2.1 Power wiring 5
 - 2.2.2 Communication Wiring RS485 6
 - 2.2.3 Overall wiring diagram 6
 - 2.3 Software settings 8
 - 2.3.1 Device connection 8
 - 2.3.2 Device testing 9
- 3. Product Overview 10
 - 3.1 Product specifications10
 - 3.2 Technical parameters 11
 - 3.3 Port Description13
 - 3.4 Dimensions 14
 - 3.5 How to install 14
- 4. Product Functions 15
 - 4.1 Analog input AI 15
 - 4.1.1 Analog input AI description 15
 - 4.1.2 Analog input AI filter parameters 15
 - 4.1.3 Analog input AI sampling range15
 - 4.1.4 Analog input AI original value, engineering measure value 16
 - 4.1.5 Analog input AI calibration 16
 - 4.2 Switch output DO 17
 - 4.2.1 Switch output DO description 17
 - 4.2.2 Switch output DO mode settings 17
 - 4.3 Device address 18
 - 4.3.1 Device address 18
 - 4.3.2 Hardware address (dial switch)..... 18
 - 4.3.3 Software address (offset address)..... 20
- 5. Port Wiring 21
 - 5.1 Analog input AI port wiring 21
 - 5.1.1 Two-wire sensor wiring 21
 - 5.1.2 Three-wire sensor wiring 21
 - 5.1.3 Four-wire sensor wiring 22
 - 5.2 Switch output DO port wiring 22
 - 5.2.1 Output direct control load (small power device within 1kW)..... 22
 - 5.2.2 Output Control Contactor (Contactor Control High Power 220V Device)..... 23
 - 5.2.3 Output Control Contactor (Contactor Control High Power 380V Device)..... 23
- 6. The Software 24

6.1 Software installation	24
6.2 Introduction to software features	25
6.2.1 IO demo interface	25
6.2.2 Basic setup interface	28
6.2.3 Advanced Settings Interface	29
6.3 Device status query	30
6.4 Device status control	32
7. Modbus Uses	34
7.1 Register List	34
7.2 List of AI-related registers	35
7.3 Instruction format (partial)	35
7.3.1 Read DO output coil status	35
7.3.2 Read Hold Register	36
7.3.3 Write a single hold register	36
7.3.4 Write multiple hold registers	36
7.3.5 Write a single DO coil status	37
7.3.6 Write multiple DO coil states	37
7.3.7 Read the input register	38
Revised history	39
About us	39

Disclaimer

EBYTE reserves all rights to this document and the information contained herein. Products, names, logos and designs described herein may in whole or in part be subject to intellectual property rights. Reproduction, use, modification or disclosure to third parties of this document or any part thereof without the express permission of EBYTE is strictly prohibited.

The information contained herein is provided “as is” and EBYTE assumes no liability for the use of the information. No warranty, either express or implied, is given, including but not limited, with respect to the accuracy, correctness, reliability and fitness for a particular purpose of the information. This document may be revised by EBYTE at any time. For most recent documents, visit www.ebyte.com.

1. Product Introduction

The MA01-XACX0440 is a support for the acquisition of four sensor analog inputs (AI), converted to serial port (RS485) data transfer to configuration software or PLC. The serial I/O networking module (also known as "Remote IO") for remote acquisition control function is realized by controlling the 4 relay switch output (DO) by sending instructions at the serial port.

Features

- Support for modbus RTU protocols;
- Support for all types of configuration software / PLC / touch screen;
- RS485 Acquisition Control IO;
- DC 8to28V power supply;
- 4 analog input AI(0 to 20mA/4 to 20mA);
- 4 switch output DO(relay);
- Switch output(DO)supports level mode, pulse mode;
- Input acquisition port isolation protection;
- Communication Baud Rate 1200to115200(default 9600),supports custom settings;
- Support for 1to247 substations,5-bit dial switch can be set 1to31 address code, greater than 31 can be set by software.



2. Quick Start

If there is a problem during use, click on the official website link: <https://www.ebyte.com/product-class.aspx>

2.1 Use preparation

Serial I/O networked devices ("IO devices") are required to prepare computers, converters, power supplies, screwdrivers and other related accessories before use. Here's how it works:

Table 2-1-1 Preparation List

serial number	Devices	quantity
1	IO devices	1
2	USB re-serial converter	1
3	Configure the tool software	1
4	Computer	1
5	Power adapter(12V/1A).	1
6	Screwdriver (one word SL 2).	1
7	Signal generator (or sensor)	1

2.2 Equipment wiring

2.2.1 Power wiring

Power supply, powered by DC 8to28V, or DC 12V or 24V.



Figure 2-2-1 Power wiring diagram

2.2.2 Communication Wiring RS485

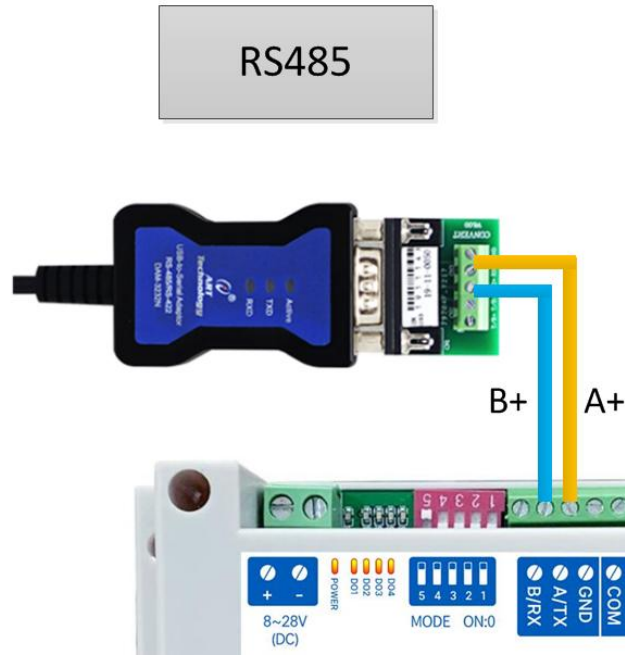

Figure 2-2-2 Communication RS485 Wiring Diagram

2.2.3 Overall wiring diagram

- (1) After power is on on the device, the power LED(POWER)is on and the power supply to the device is ok.
- (2) Analog input AI wiring, as shown by connecting the signal generator to the analog input AI port.
- (3) Switch output DO wiring, as shown by connecting the load to the switch output DO port.

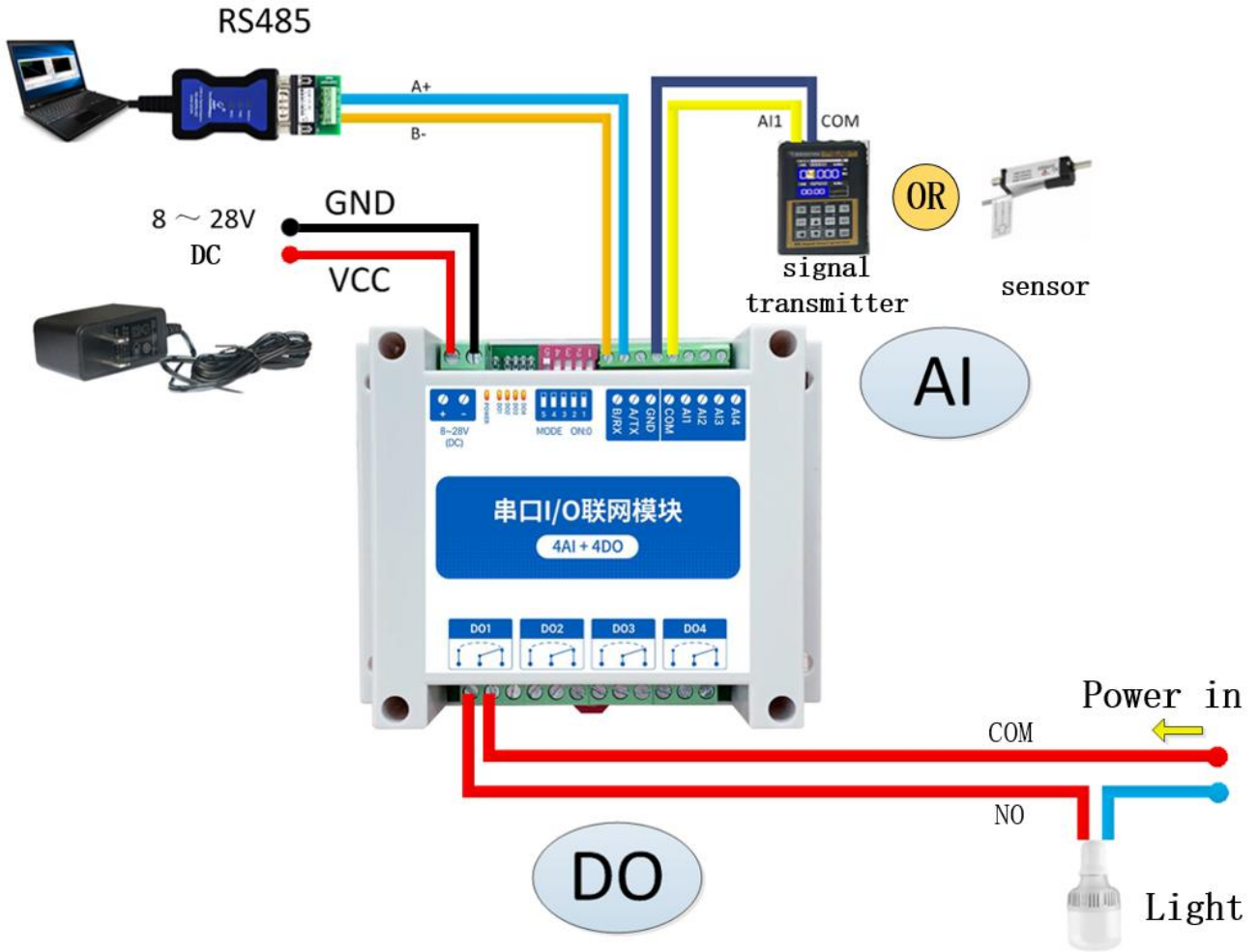

Figure 2-2-4 overall wiring diagram

2.3 Software settings

2.3.1 Device connection

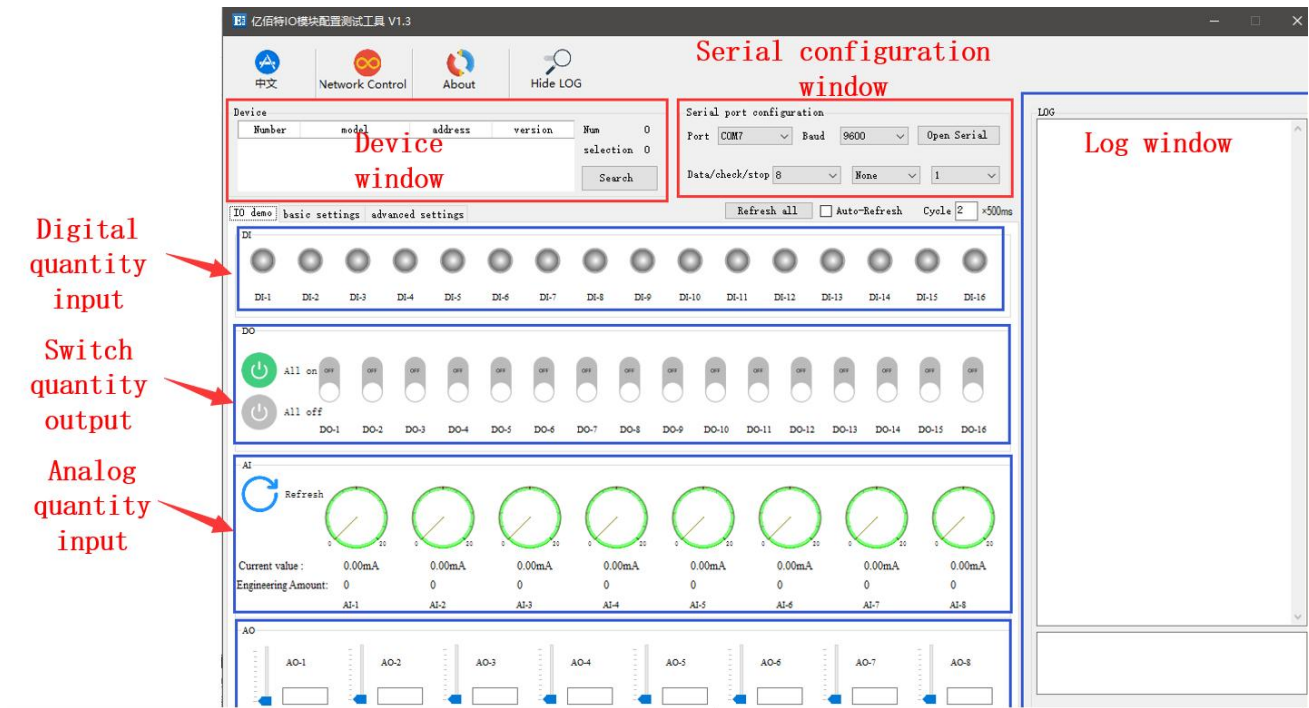

Figure 2-3-1 Software Interface

How to do this:

(1) Open the serial port, find the corresponding device port number, Baud rate default 9600,click "Open serial port."

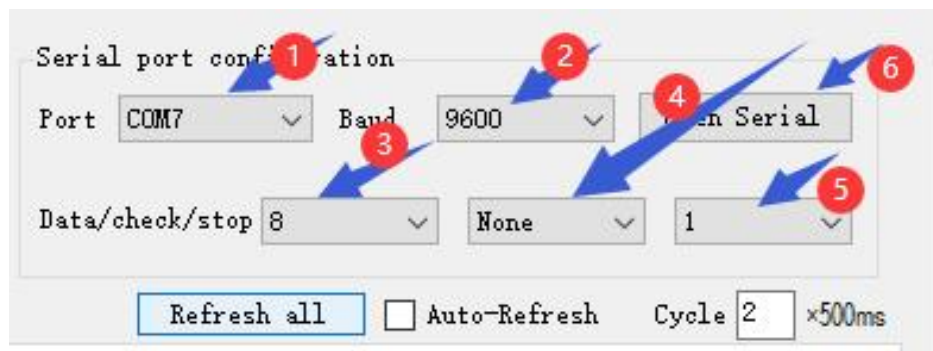

Figure 2-3-2 Opens the serial port

(2) In the device window, click "Search device" and the log window on the right starts refreshing the search information. After the device section of the device window shows the connected device, click the "Stop Search" menu. Then select the device click, the connection is successful.

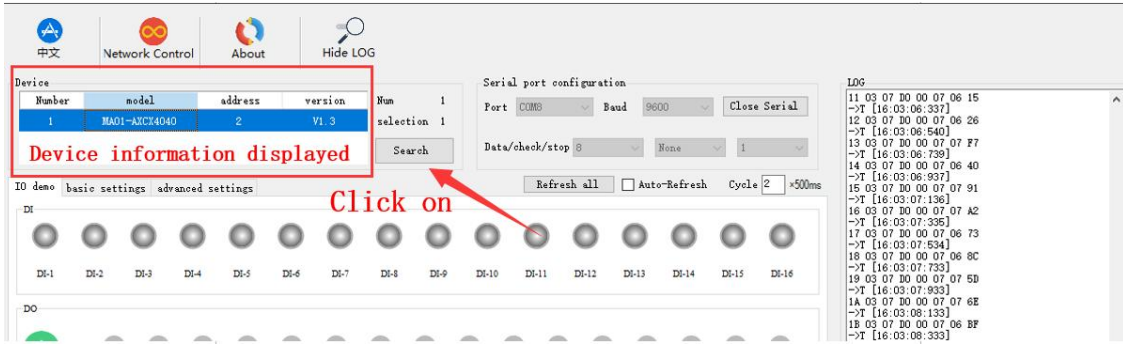

Figure 2-3-3 Connecting devices

2.3.2 Device testing

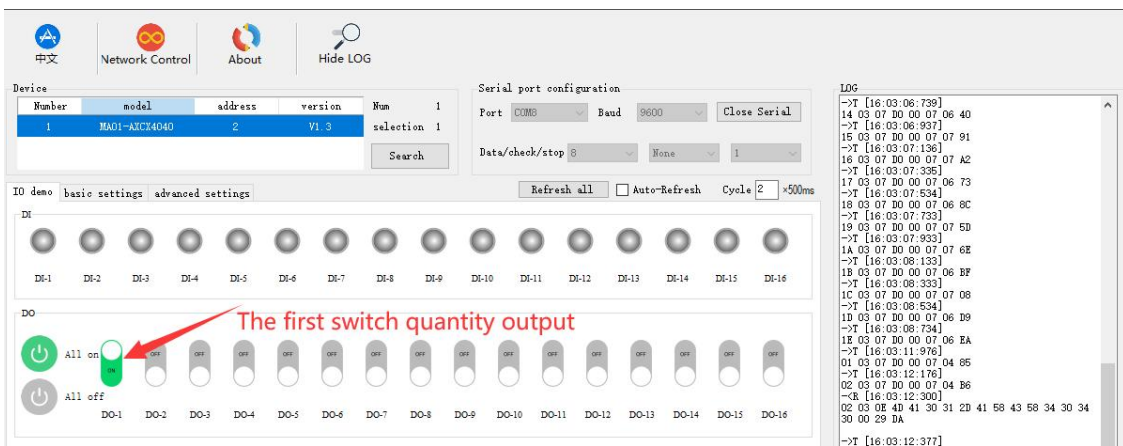

Figure 2-3-4 Device Testing

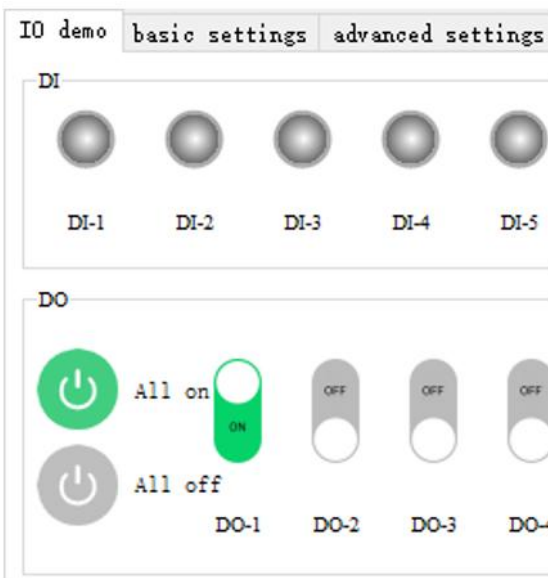

Figure 2-3-5 Actual test results

3. Product Overview

3.1 Product specifications

Table 3-1-1 Product Specifications

Product model	specification	The switch quantity is entered DI	The analog input AI	Switch volume output DO	RS485	RS232
MA01-AXCX4020	4DI+2DO	4 way	—	2 way	●	×
MA02-AXCX4020		4 way	—	2 way	×	●
MA01-XACX0420	4AI+2DO	—	4 way	2 way	●	×
MA02-XACX0420		—	4 way	2 way	×	●
MA01-AACX2220	2DI+2AI+2D O	2 way	2 way	2 way	●	×
MA02-AACX2220		2 way	2 way	2 way	×	●
MA01-AXCX4040	4DI+4DO	4 way	—	4 way	●	×
MA02-AXCX4040		4 way	—	4 way	×	●
MA01-XACX0440	4AI+4DO	—	4 way	4 way	●	×
MA02-XACX0440		—	4 way	4 way	×	●
MA01-AACX2240	2DI+2AI+4D O	2 way	2 way	4 way	●	×
MA02-AACX2240		2 way	2 way	4 way	×	●
MA01-XXCX0080	8TH	—	—	8 way	●	×
MA02-XXCX0080		—	—	8 way	×	●

3.2 Technical parameters

Table 3-2-1 Technical Parameters

category	name	parameter
power supply	Operating voltage	DC 8 to 28V
	Operating current	50mA @12V
	The power supply indicates	Green LED indication
Serial	Communication interface	RS485
	baud rate	1200 to 115200 bps (default 9600 bps)
	The data bit	8 (Fixed).
	Check bit	No checks, parity, parity (default no checks)
	Stop bit	1 (Fixed).
	Communication protocol	Modbus RTU protocol
	The device address	1 to 247 (default address3 2:Software 1, hardware 31).
AI input	The number of AI roads	4 way
	Collection range	0~20mA / 4~20mA
	resolution	12 bits
	Acquisition accuracy	3‰
	The acquisition frequency	10 Hz
	Acquisition characteristics	Single-ended input
	Enter the impedance	100Ω
DO output	The number of DO roads	4 way
	The DO output type	Type C relay (normally open and normally closed)
	DO output mode	Level mode, pulse mode
	Relay contact capacity	30V/10A☆250V/10A
	The output indicates	Red LED indication
other	Product size	115 mm x 90 mm x 40 mm (long x width x high)
	Product weight	160g ± 5g
	Working	-40 to 85 degrees C, 5% to 95% RH (no condensation)

	temperature and humidity	
	Store temperature and humidity	-60 to 125 degrees C, 5% to 95% RH (no condensation)
	How to install it	Positioning hole installation, rail installation

3.3 Port Description

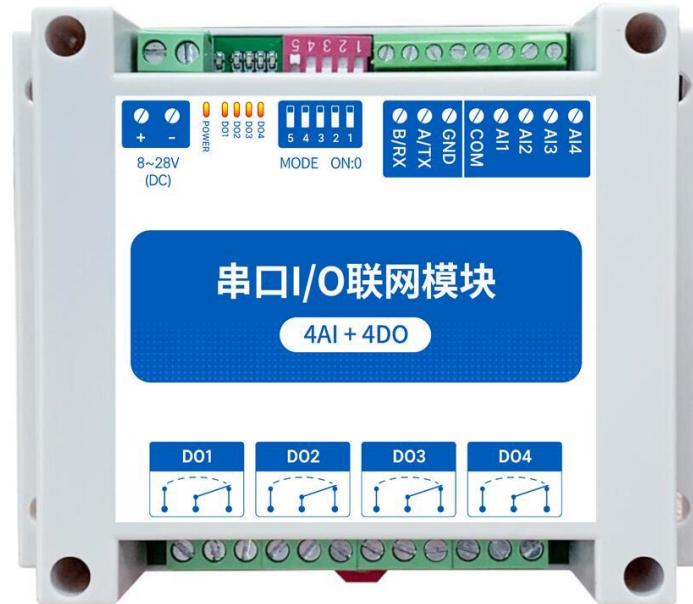

Figure 3-3-1 Interface Diagram

Table 3-3-1 Port Feature Table

numbering	Pins	illustrate	remark
1	+	Power supply . .	It is recommended that RVV 2 x 0.75 wire
2	-	Ground -	
3	B/RX	RS485 corresponds to B	It is recommended that RVSP 3 x 0.5 wire
4	A/TX	RS485 corresponds to A	
5	GND	The signal is grounded	
6	WITH	Enter the common end of the channel	It is recommended that RVV 2 x 0.5 wire
7	AI1	Analog input channel 1	
8	AI2	Simulate input channel 2	
9	AI3	Analog input channel 3	
10	AI4	Analog input channel 4	Relays have normal open and normal closed ends
11	DO1	Switch output channel 1	
12	DO2	Switch output channel 2	
13	DO3	Switch output channel 3	
14	DO4	Switch output channel 4	

3.4 Dimensions

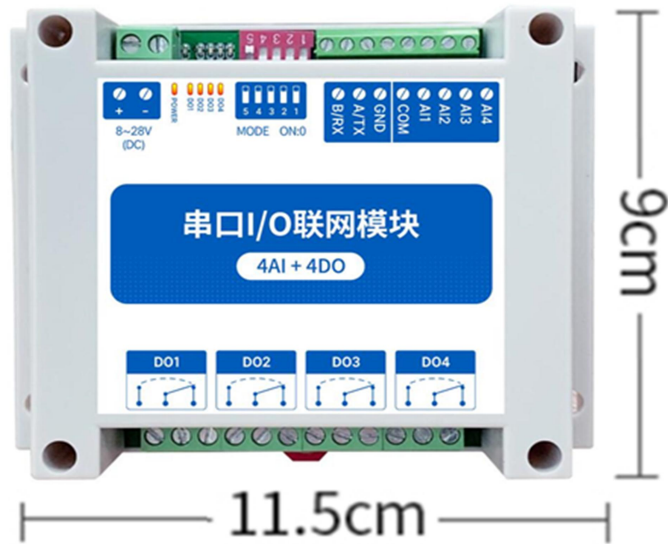
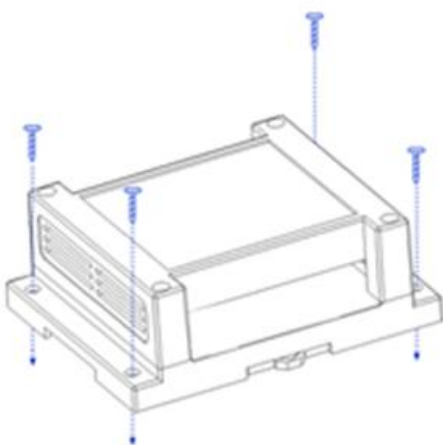

Figure 3-4-1 Dimensions

3.5 How to install

The device supports positioning hole installation or railing.



Positioning hole installation

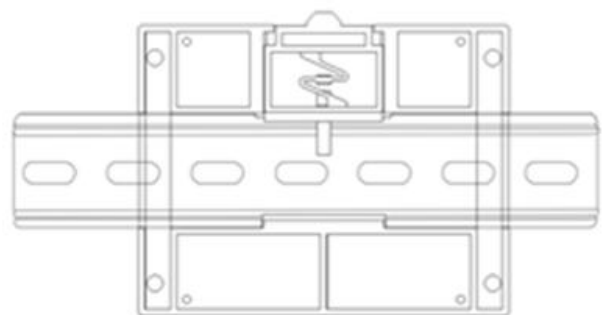

Rail installation

Figure 3-5-1 How to install

4. Product Functions

4.1 Analog input AI

4.1.1 Analog input AI description

Analog input AI measures current signals with acquisition ranges from 0to20mA or 4to20mA,with 3-bitaccuracy and 12-bit resolution. With single-ended input, sampling frequency 10Hzand input impedance of 100Ω.

4.1.2 Analog input AI filter parameters

The filter parameters for the AI channel can be set with a valid value of 1to16and a default of 6.

concentrate:

(1) Ai channel filtering parameters are all AI channels share a filter parameter. The larger the filter parameters, the stronger the AI sampling anti-jamming capability, but at the same time has delay.

(2) The address of the AI channel filter parameter is 0x04B0 and the register type is the hold register. Function code 0x06, 0x10. When AI filter parameters are written, if the parameter values written are not within the range of 1 to 16, the closest values are automatically taken to write, such as write filter parameters of 0, then the device takes 1 as the filter parameters, and Modbus does not return error instructions.

4.1.3 Analog input AI sampling range

Set the sampling range for all AI channels with valid values of 1 and 0 (default 0).

0: represents 0 to 20mA

1: Represents 4 to 20mA

- (1) The AI sampling range is shared by all channels, and when the AI channel sampling range is configured for sampling from 4to20mA, the engineered value of the channel is converted to 0 if the current signal is below 4mA. There is no conversion limit for signals greater than 20mA, but no more than 25mA (more than 25mA there is a risk of equipment damage).
- (2) The AI channel sampling range parameter address is 0x 04B2, register type is hold register, function code 0x06, 0x10. When the AI channel sampling range parameter is written, if the parameter value written is not within the range of 0to1, the closest value is automatically written, such as write Sample range parameter 2, then the device takes 1 as the sampling range parameter, and MDOBUS does not return error instructions.

4.1.4 Analog input AI original value, engineering measure value

There are two ways to read the current signal size collected by the device:

- (1) Read the original AI value and calculate the input current based on the input impedance.

The original VALUE register address for AI is 0x0000to0x0003,the register type is the input register, and the read function code is 0x04. The value returned by this method is 2 bytes for a channel, and the numbers read range from 0to4095. The current size is calculated by 0to4095 for 0to25mA.

The register type is discrete input register and the read function code is 0x04.

namely

$$current = \frac{original\ value}{4095} \times 25\ (mA)$$

- (2) Read the AI engineering measure and convert directly to get the input current.

The AI engineering value register address is 0x0064to0x0067, the register type is the input register, and the read function code is 0x04. This method returns a value of 2 bytes for 1 channel and reads a value of 0to25000. The current size is calculated by 0to25000 for 0to25mA. That is

$$current = \frac{Engineering\ quantity}{1000}\ (mA)$$

4.1.5 Analog input AI calibration

When the AI measurement current is read with a large error, it can be calibrated by setting the high and low calibration registers for each channel.

Each CHANNEL has its own high (low) point calibration register with high-point calibration register addresses of 0x0190to0x0193,and low calibration registeraddresses of 0x0258to0x025C. Register type is hold register with function codes of 0x06,0x10.

The calibration method can enter a precise current signal for the AI channel, and the write value is calibrated. For example, if the device is calibrated for the AIx channel, the actual input current is 20mA,at which point the original AI value of the AIx channel is read and the original value is written to the high calibration register of the AI channel. The general low calibration can default to 0 not set.

Note: This function is calibrated and is used only when the error is large. It is not recommended in general.

4.2 Switch output DO

4.2.1 Switch output DO description

Switch output DO with level mode, pulse mode, follow mode (follow DI only). With the Type C relay output (normally on and normally closed), the single output supports a maximum load (contact capacity) of 30V/10A or 250V/10A.

Each DO output is designed with an output indicator (red LED indication) indicating that the output port is off. When the LED is on, it means that the relay is sucked (normally on, normally closed and disconnected); When the LED is off, the relay is not sucked (normally open, normally closed).

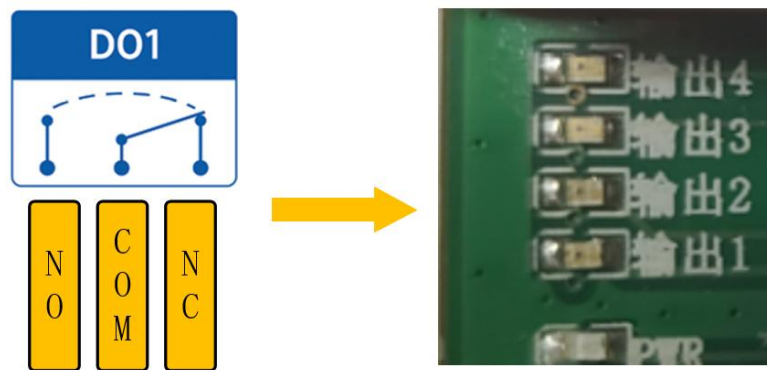

Figure 4-2-1 Switch output DO interface

4.2.2 Switch output DO mode settings

(1) level mode

Depending on the level set by the user, the switching characteristics of the level mode are similar to those of the self-locking switch.

(2) pulse mode

When the switch output DO is on, the switch output DO switches off automatically after the set pulse width time (in ms) is maintained. Pulse width settings range from 50 to 65535 (default 50).

(3) Follow the mode

After the user sets the follow mode, set the following input after. The switch output DO side is consistent with the DI input.

Note: Multiple switch output DO ends can be set to follow one DI input, not one switch output DO side to follow multiple DI inputs.

4.3 Device address

4.3.1 Device address

Device address composition: Hardware address and software offset address

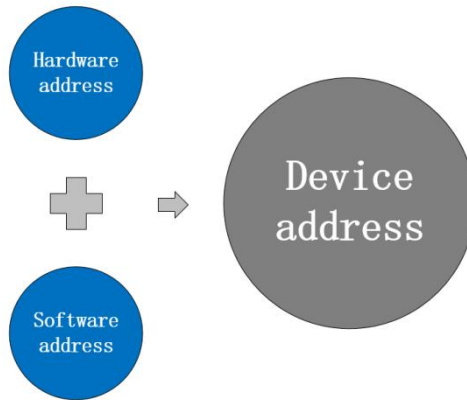

Figure 4-3-1 Device Address

The device address defaultsto: 32(hardware address 31 plus software address 1 - device address 32).

Device address settings range:1to247.

Hardware address: Implemented by dial switch(5-bit) dial setting (factory default is 31).

Software address: Implemented by the configuration tool software setting Offset Address (factory default is 1).

Example:

If the hardware address is set to 5and the software address is set to 113,the device addressis 118.

4.3.2 Hardware address (dial switch).

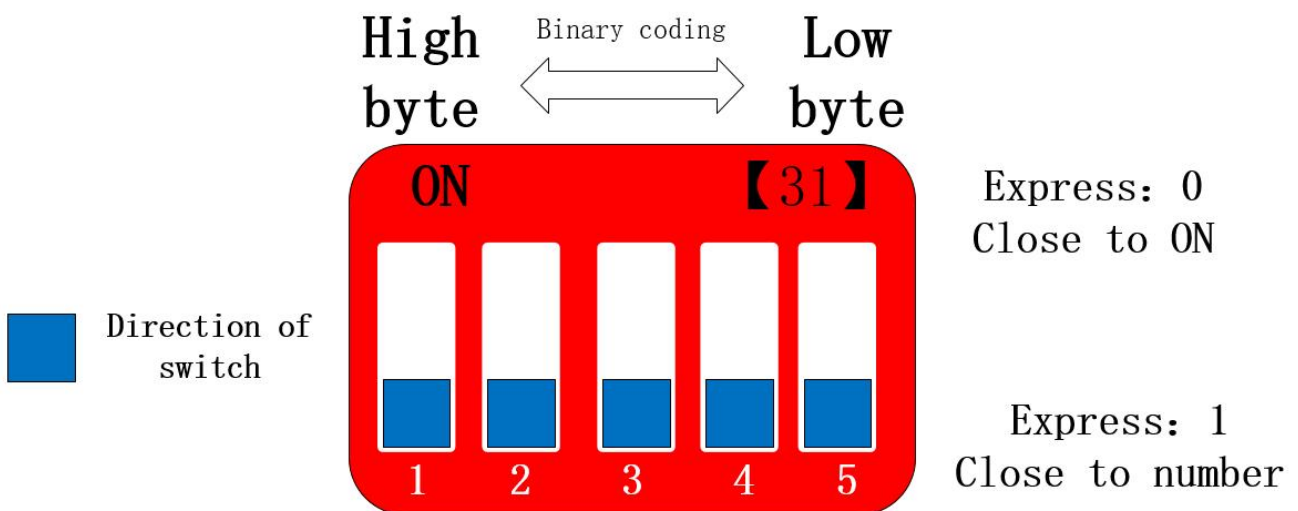

Figure 4-3-2 Hardware Address (Dial Switch)

Hardware address: The dial switch switches different hardware addresses, and binary represents a 5-digit dial switch. The "5" direction indicates the low bit and the "1" direction indicates the high bit. Hardware address range adjustable range 0 to 31.

Hardware Address Dial Settings Description:

Example 1: Set hardware address 0, binary encoding.

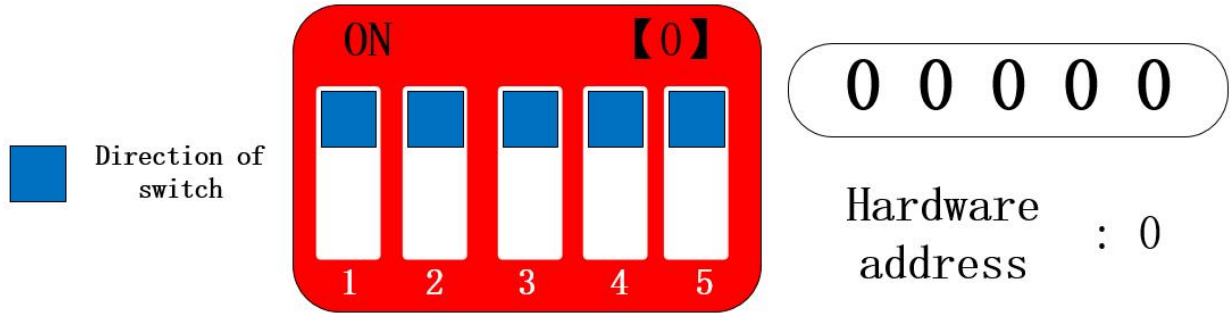

Figure 4-3-3 Hardware Address 0

Example 2: Set hardware address 8, binary encoding.

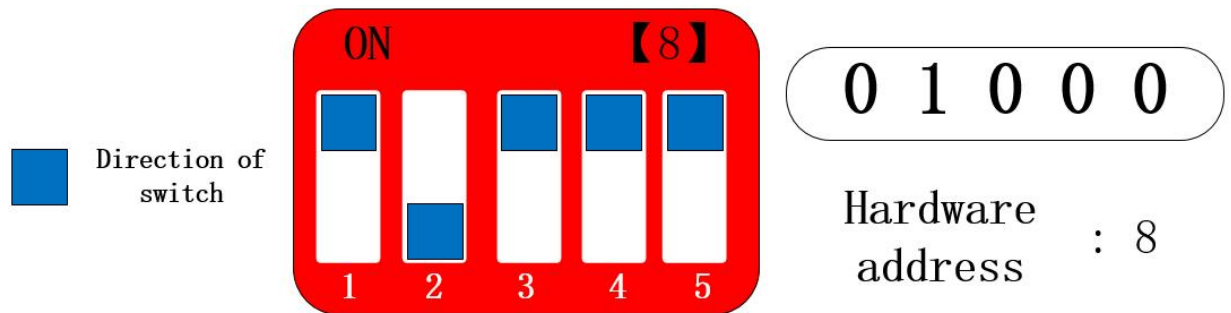

Figure 4-3-4 Hardware Address 8

Example 3: Set hardware address 31, binary encoding.

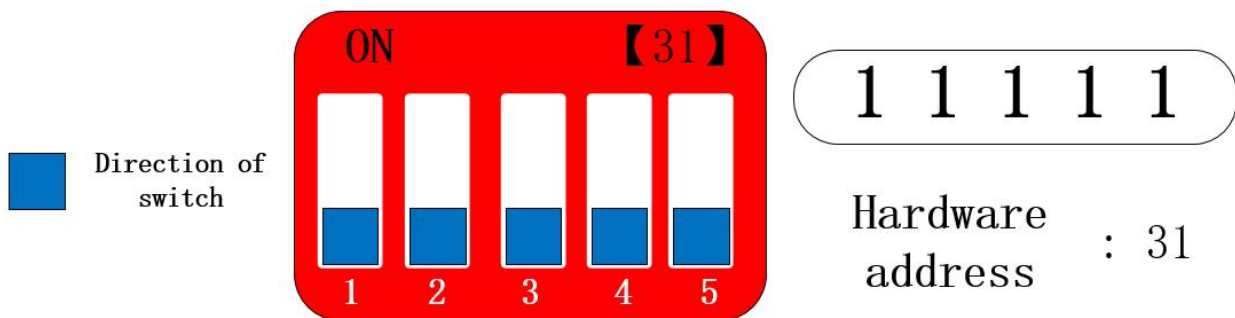

Figure 4-3-5 Hardware Address 31

Hardware address, can be customized according to the actual situation, the setting method as shown in the above example.

If multiple devices are required to connect to a single RS485 bus, they can hang on up to 32 devices (just set up a hardware address) via a hardware address.

If you need more than 32 devices to connect to a single RS485 bus, you need to set up a software address (offset address) to connect up to 247 devices to a single bus.

After you change the address, you need to power down restart before the new address set is effective.

4.3.3 Software address (offset address).

Software address: Users can make different settings depending on the scene. The software address setting range is 1 to 24 (device address: 1 to 247), and the software address defaults to 1.

After you change the address, you need to power down restart before the new address set is effective.

Changing the software address is done through the configuration tool software, as shown in the figure:



Figure 4-3-7 Software Address (Offset Address)

5. Port Wiring

5.1 Analog input AI port wiring

5.1.1 Two-wire sensor wiring

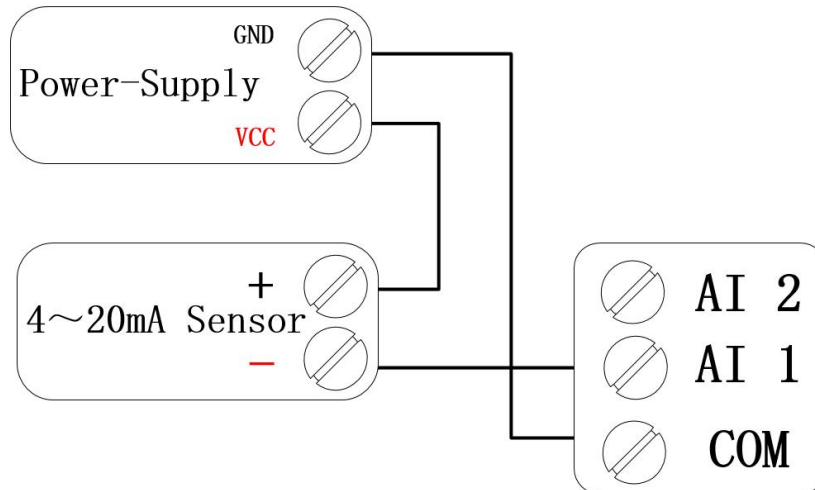

Figure 5-1-1 Two-wire sensor wiring diagram

5.1.2 Three-wire sensor wiring

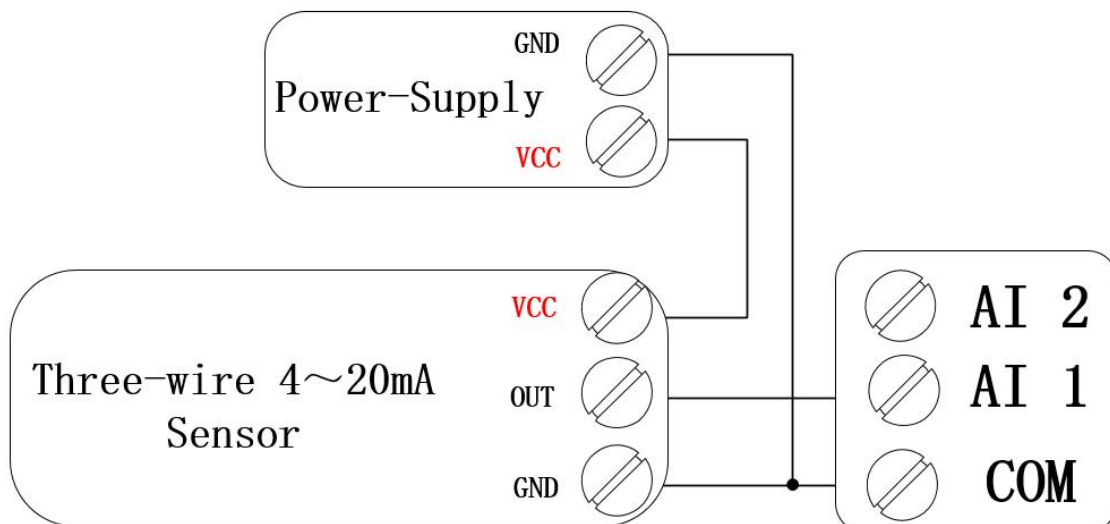

Figure 5-1-2 Three-wire sensor wiring diagram

5.1.3 Four-wire sensor wiring

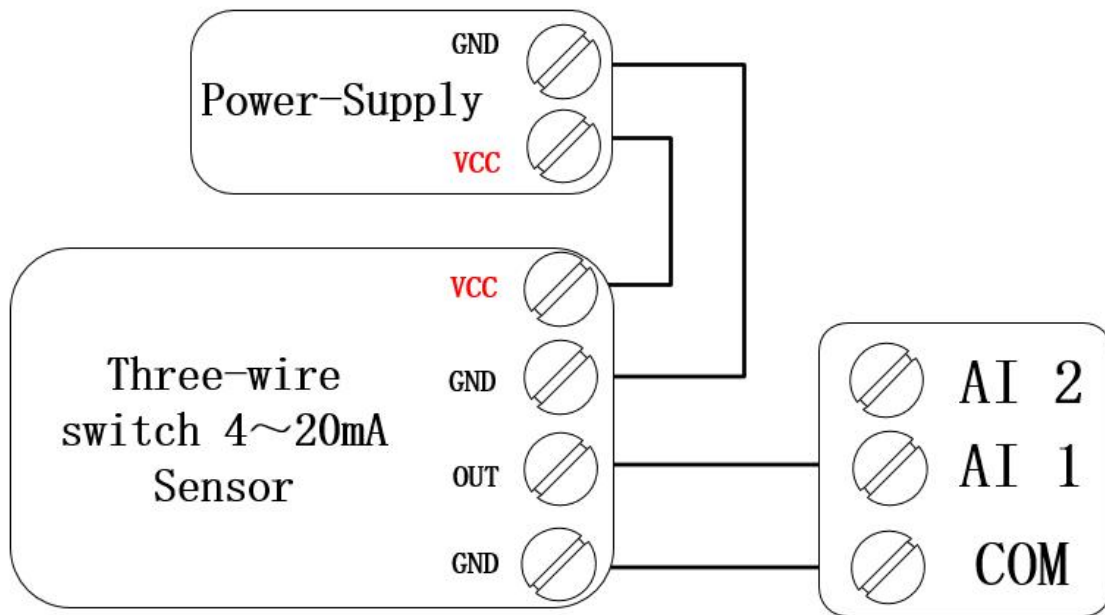

Figure 5-1-3 Four-wire sensor wiring diagram

5.2 Switch output DO port wiring

5.2.1 Output direct control load (small power device within 1kW).

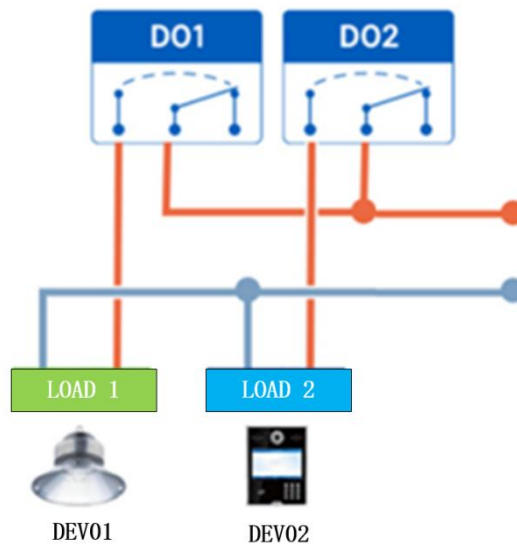

Figure 5-2-1 Output Direct Control Load Wiring Diagram

5.2.2 Output Control Contactor (Contactor Control High Power 220V Device).

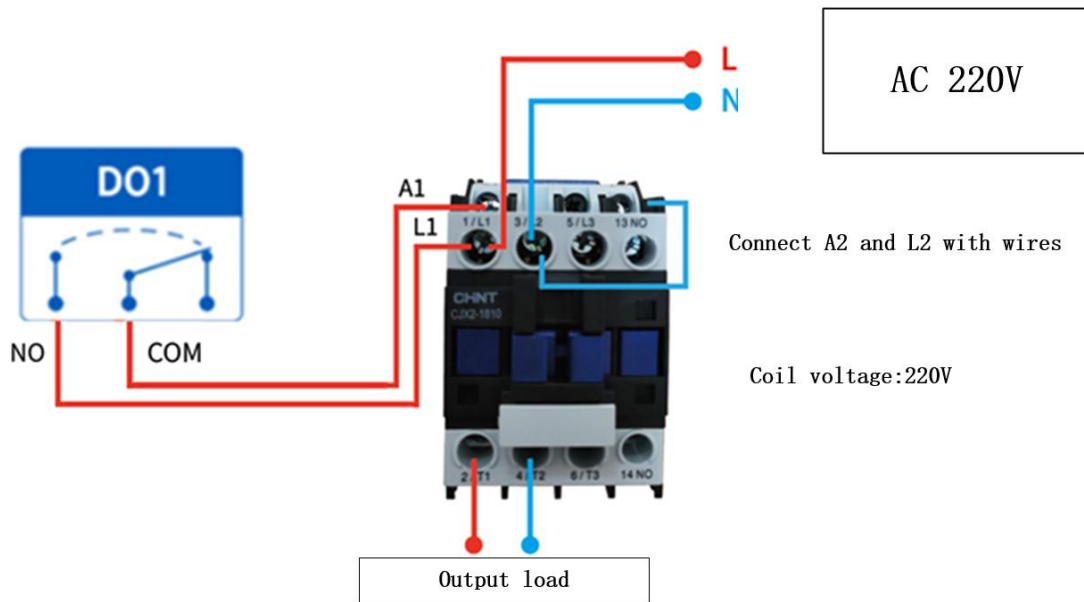

Figure 5-2-2 Output Control Contactor Wiring Diagram

Note: The figure above takes the contactor coil voltage AC 220V as an example, **the coil voltage may be different from contactor.**

5.2.3 Output Control Contactor (Contactor Control High Power 380V Device).

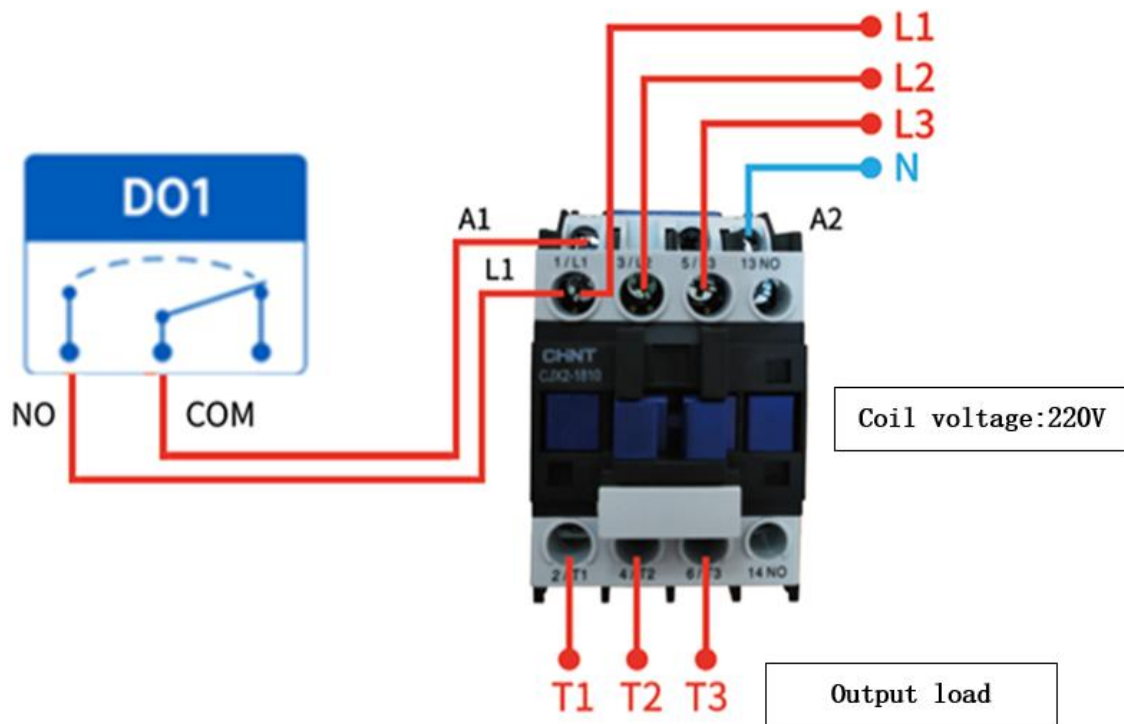

Figure 5-2-3 Output Control Contactor Wiring Diagram

Note: The figure above takes the contactor coil voltage AC 220V as an example, **the coil voltage may be different from contactor.**

6. The Software

6.1 Software installation

The configuration tool software is driver-free and is ready to use by double-clicking directly on the .exe file open.



Figure 6-1-1 Software Installation File

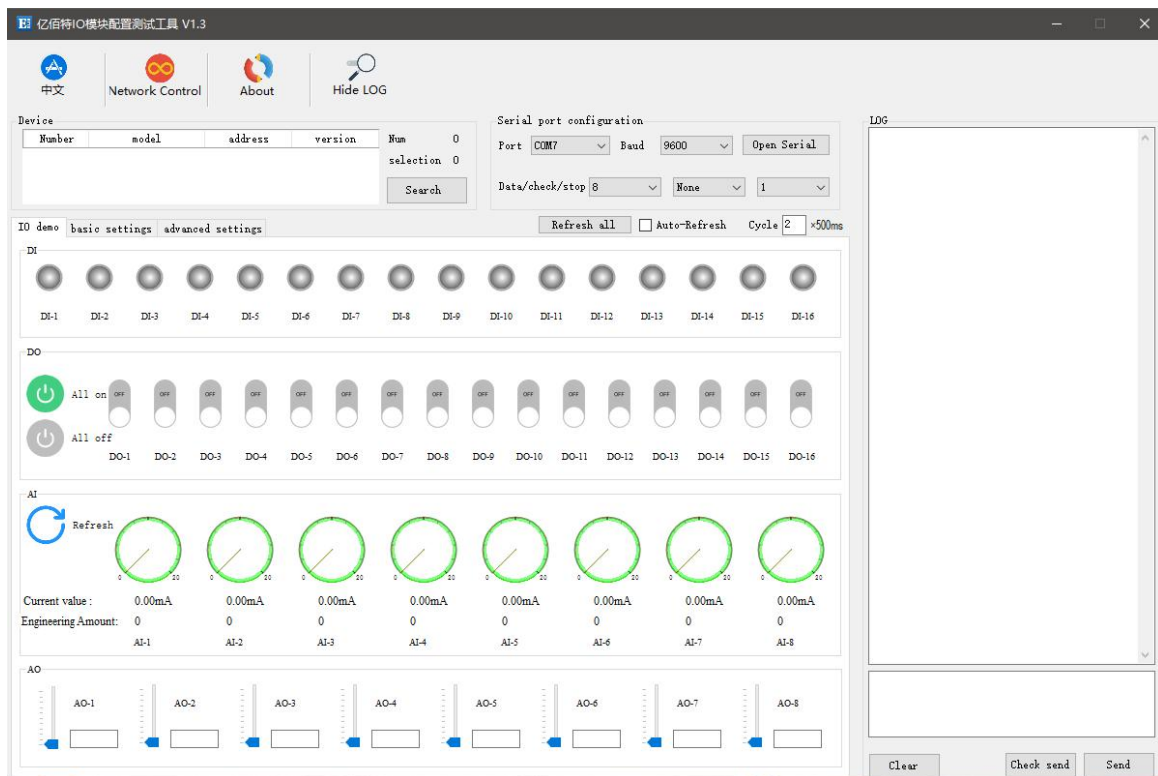

Figure 6-1-2 The software installation successfully opens the interface

6.2 Introduction to software features

6.2.1 IO demo interface

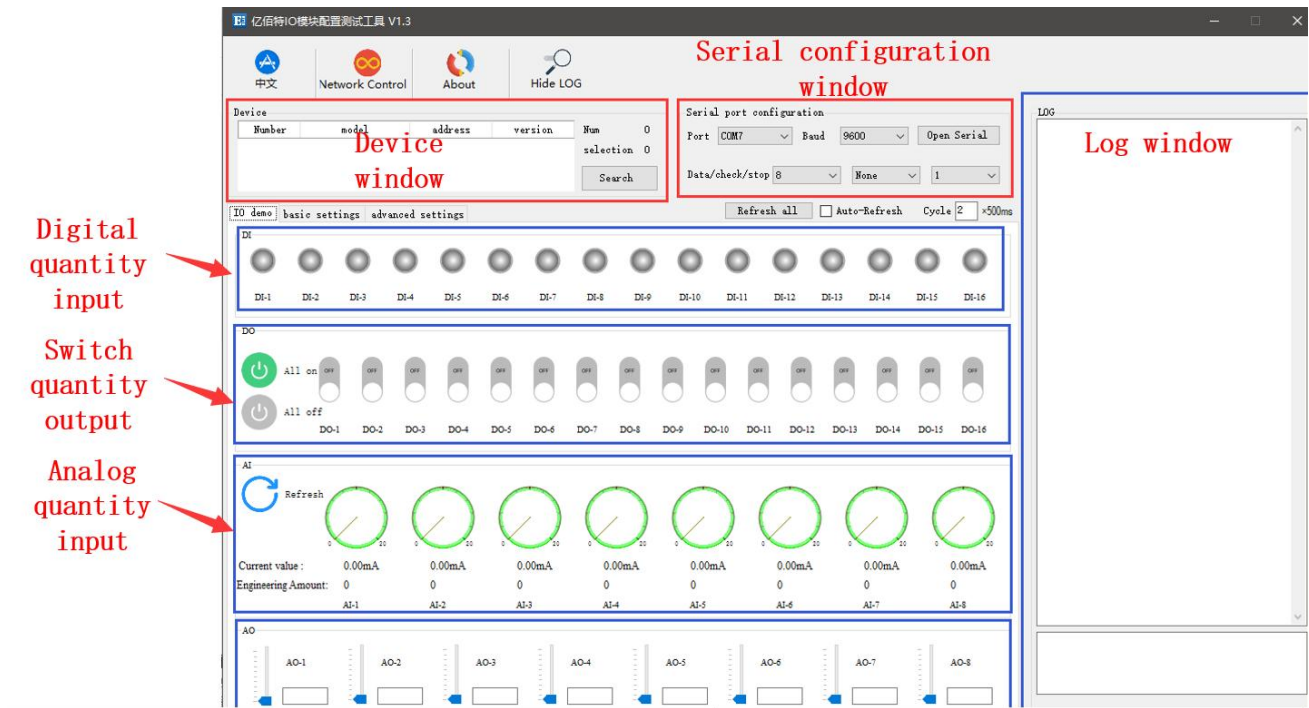

Figure 6-2-1 Software IO Demo Interface

(1) The device window

Displays the current connection device information (serial number, device model, device address, firmware version).

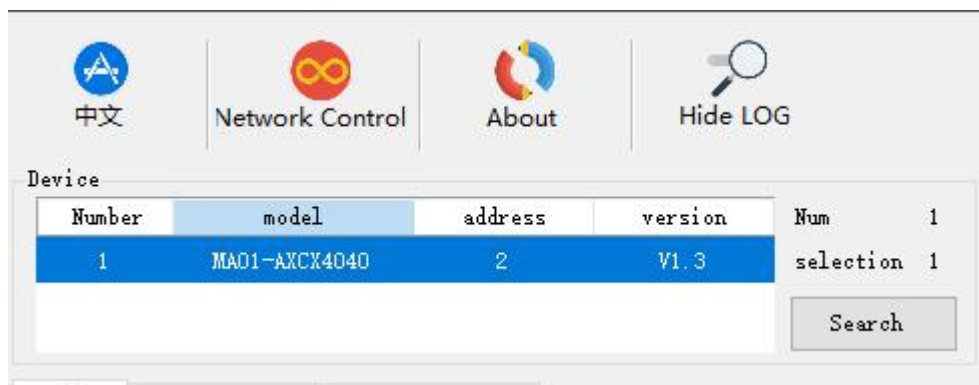

Figure 6-2-2 Device Window Interface

(2) Serial parameter window

Displays serial parameter information (port, baud rate, data bit, check bit, stop bit, etc.) and opens serial port.



Figure 6-2-3 Serial Parameter Window Interface

(3) The log window

Displays the device configuration, the operation log information during use (send, return data instructions).

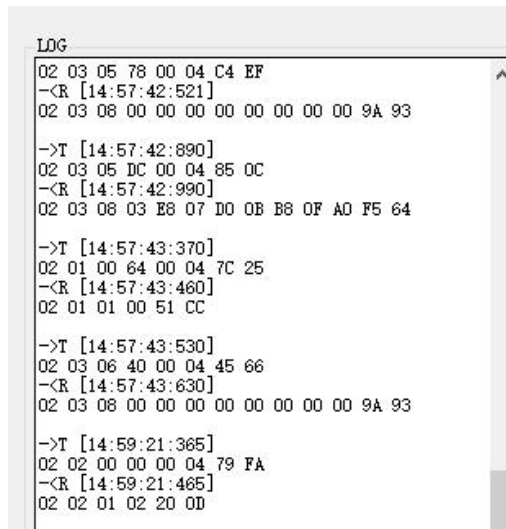

Figure 6-2-4 Log Window Interface

(4) Switch input DI(this feature is limited to DI-enabled devices).

Displays the status of the digital input DI port.

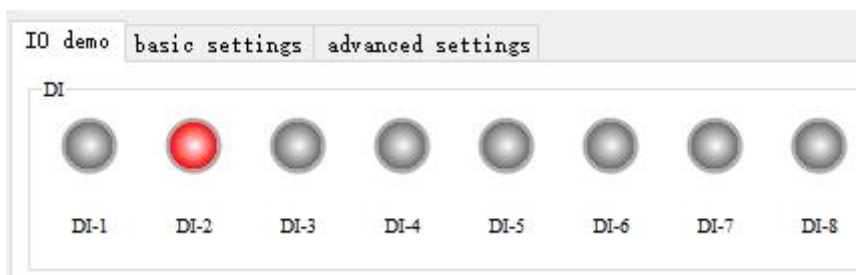

Figure 6-2-4 Switch Input DI interface

(5) Switch output DO

Displays the status of the DO port of the switch output, and the graphical settings switch output of the DO port is on and off.

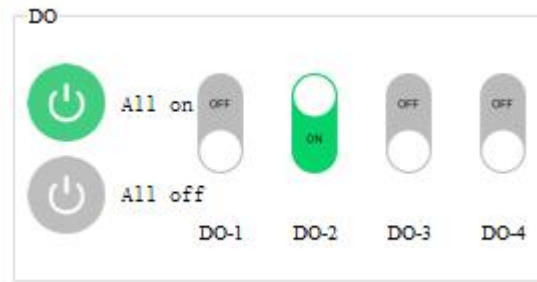

Figure 6-2-5 Switch Output DO interface

(6) Analog input AI (this feature is limited to AI-enabled devices).

Displays the status of the analog input AI port (current, engineering volume), indicated by a graphical pin.

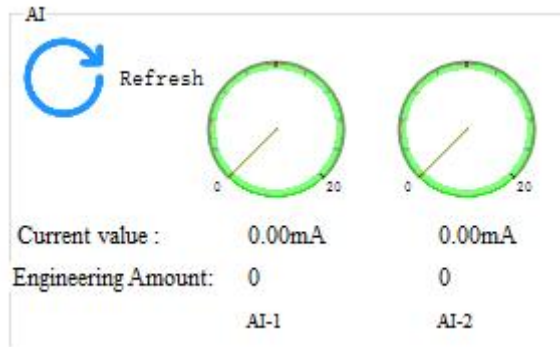

Figure 6-2-6 Simulates input AI interface

(7) Refresh the settings

Supports manual refresh, automatic refresh status. The auto-refresh state can customize the refresh cycle, which is a multiple of 500ms.

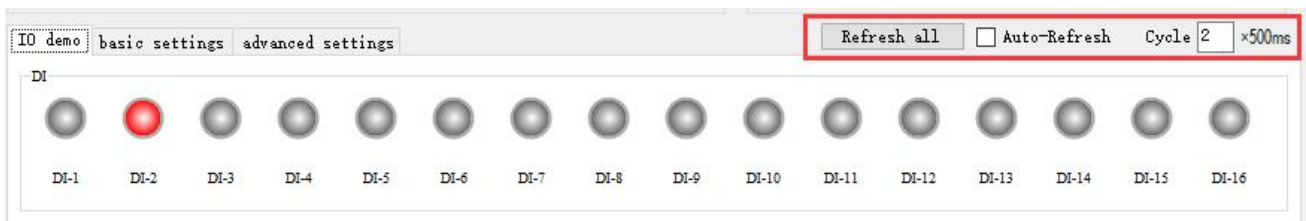

Figure 6-2-7 Refresh the settings interface

6.2.2 Basic setup interface

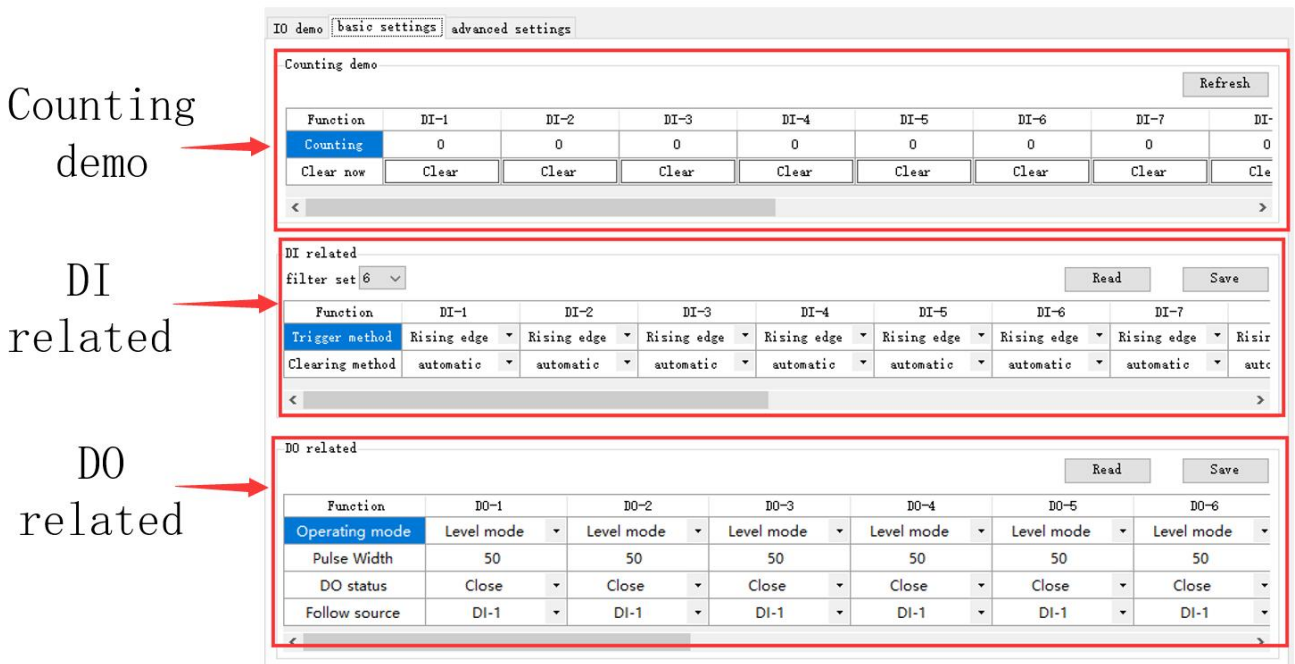

Figure 6-2-8 Basic setup interface

(1)Count demo

Displays DI count information, zeroing settings. This feature is limited to DI-enabled devices

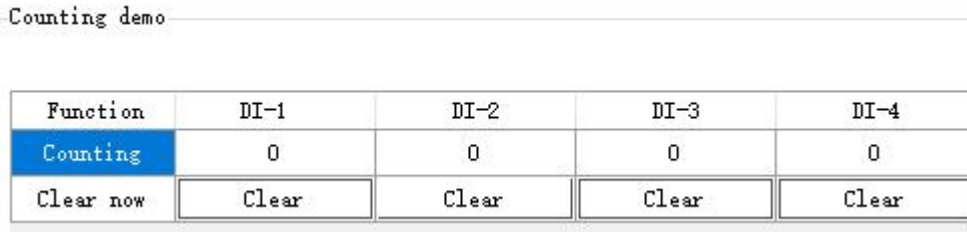

Figure 6-2-9 Count Demo Interface

(2) DI-related

Set up the DI function. Set the filter parameters(1to16),trigger(rising, falling, level), and zeroing (automatic, manual). This feature is limited to DI-enabled devices

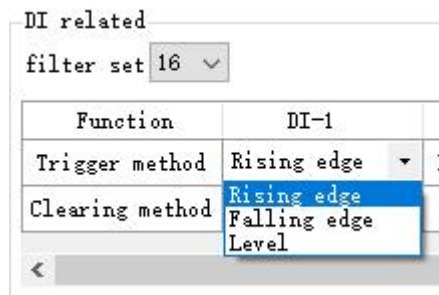

Figure 6-2-10 "DI-related" interface

(3) DO-related

Set the DO function, set the operating mode (level mode, pulse mode, follow mode), set the pulse width (pulse mode only), power up the DO state (on, off), follow the source (follow the setting DIx).

Note: Multiple switch output DO ends can be set to follow one DI input, not one switch output DO side to follow multiple DI inputs. Follow mode is limited to DI-enabled devices

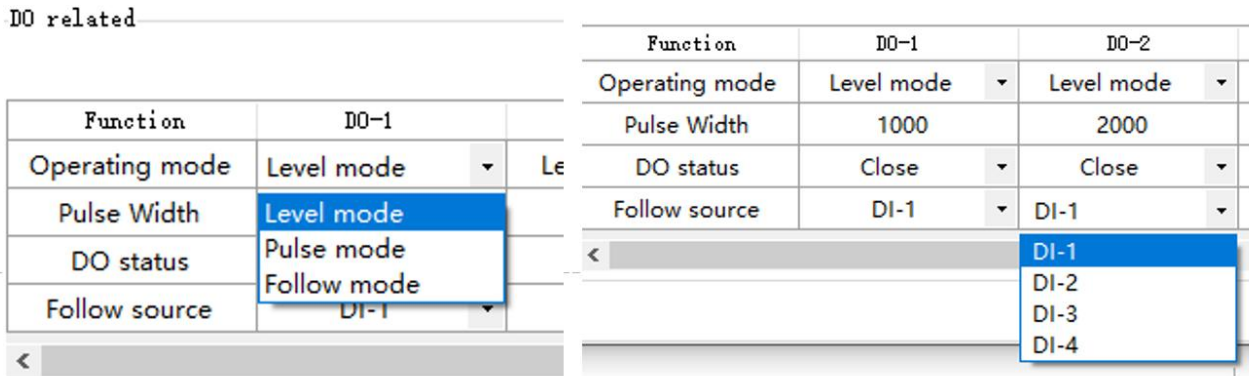

Figure 6-2-11 "DO-related" interface

6.2.3 Advanced Settings Interface

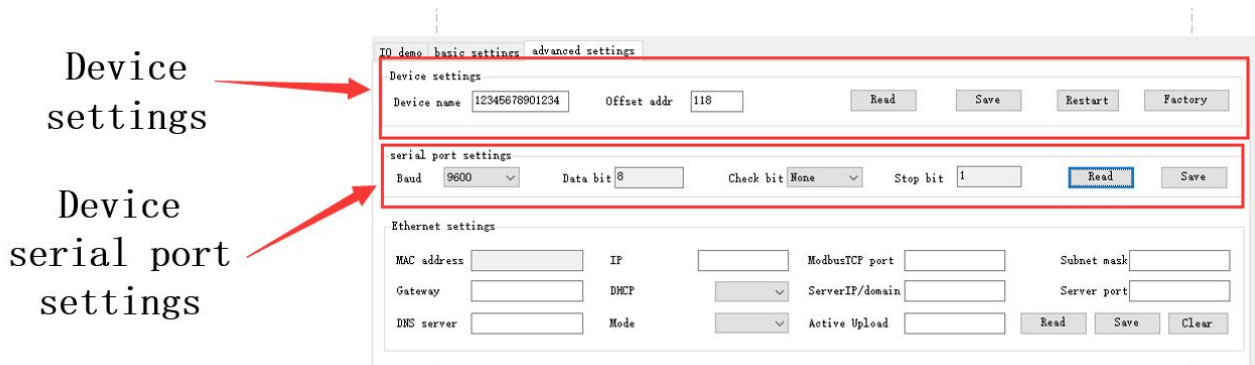

Figure 6-2-12 Advanced Settings Interface

(1) Device settings

Advanced setup interface, support for device name settings, offset address (software address), read parameters, turn on write protection, turn off write protection, restart modules, restore factory settings.



Figure 6-2-13 Device Settings Interface

(2)Device serial settings

Supports setting Baud Rate(1200,2400, 4800,9600,19200,38400,57600,115200)by default 115200.

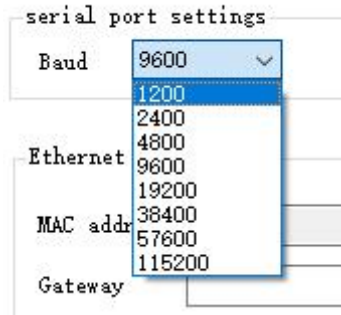

Figure 6-2-14 Baud Rate Settings Interface

Supports setting check bits, which can be set (none, parity, parity), and no checks by default.

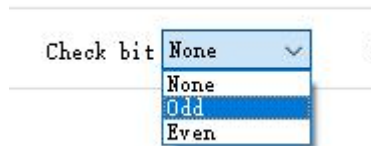

Figure 6-2-16 Check bit settings interface

6.3 Device status query

The configuration software supports device status queries, and once the device is connected, the device status can be queried through the Refresh All Data menu.

Example: The configuration software is connected to 2 devices, try to query select one of the devices, click on the "Refresh all data" menu, complete the device status query.

(1)IO demo interface

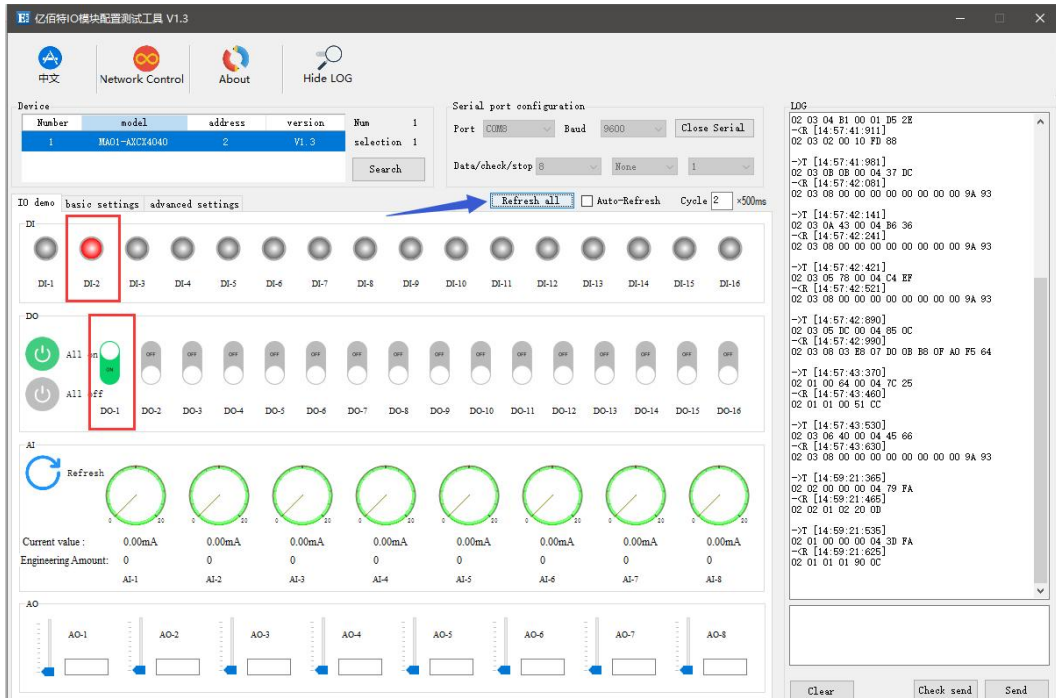

Figure 6-3-1 Device Status Query(IO Demo Interface).

(2)Basic setup interface

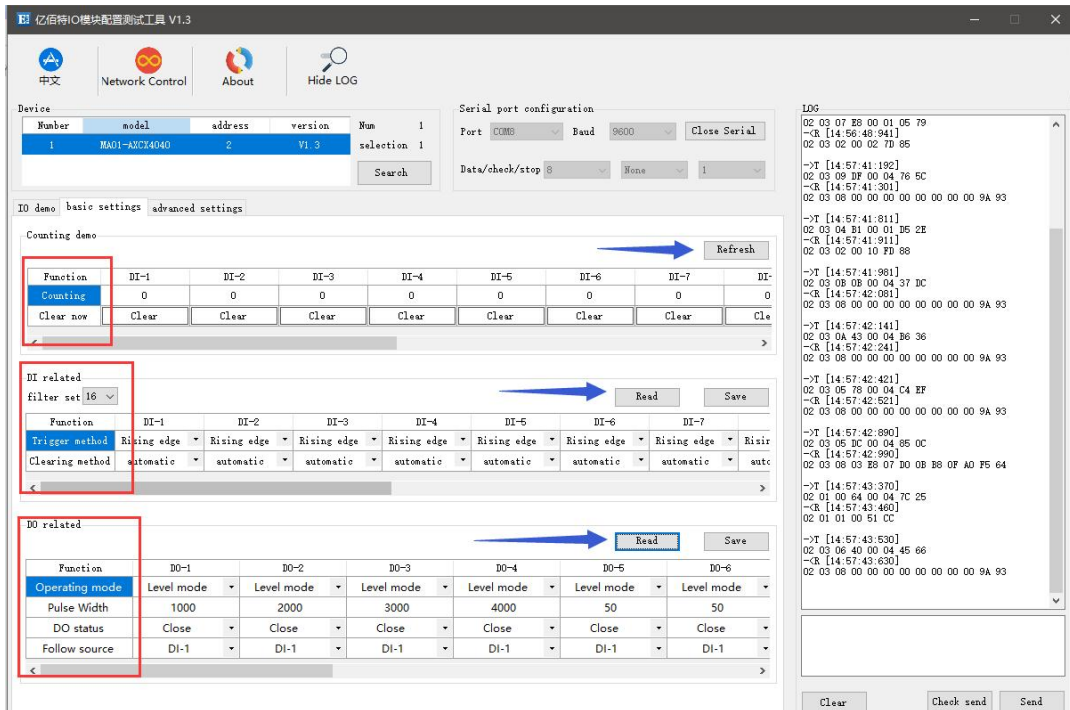

Figure 6-3-2 Device Status Query (Basic Settings Interface).

(3)Advanced settings interface

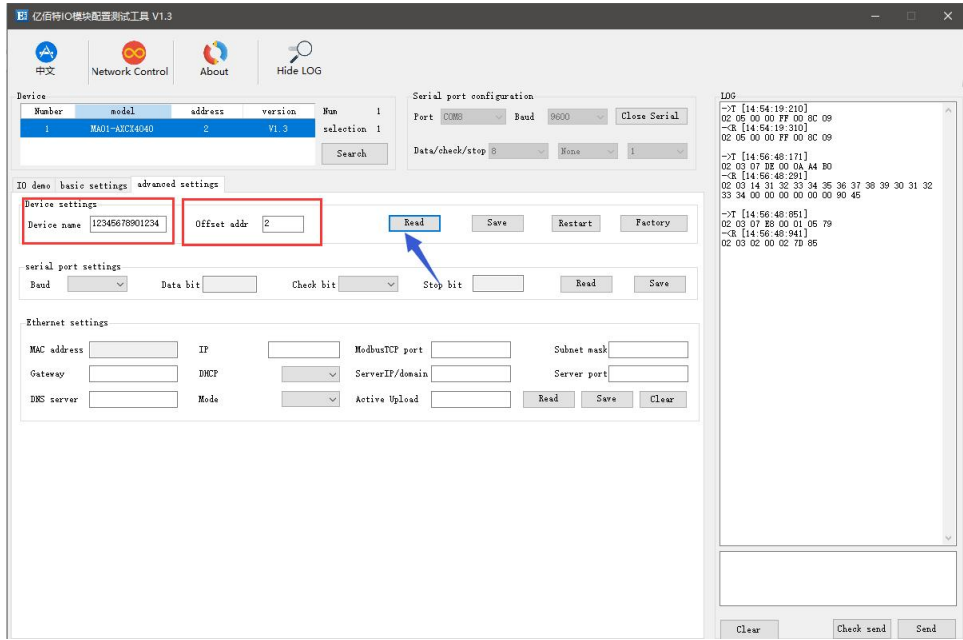

Figure 6-3-3 Device Status Query (Advanced Settings Interface).

6.4 Device status control

Device status control, device support for Modbus standard command control. Configuration software graphical control is also supported.

Example: Control the device and turn on the DO-1 output port.

Method 1: Software graphical operation, click on the menu button control.

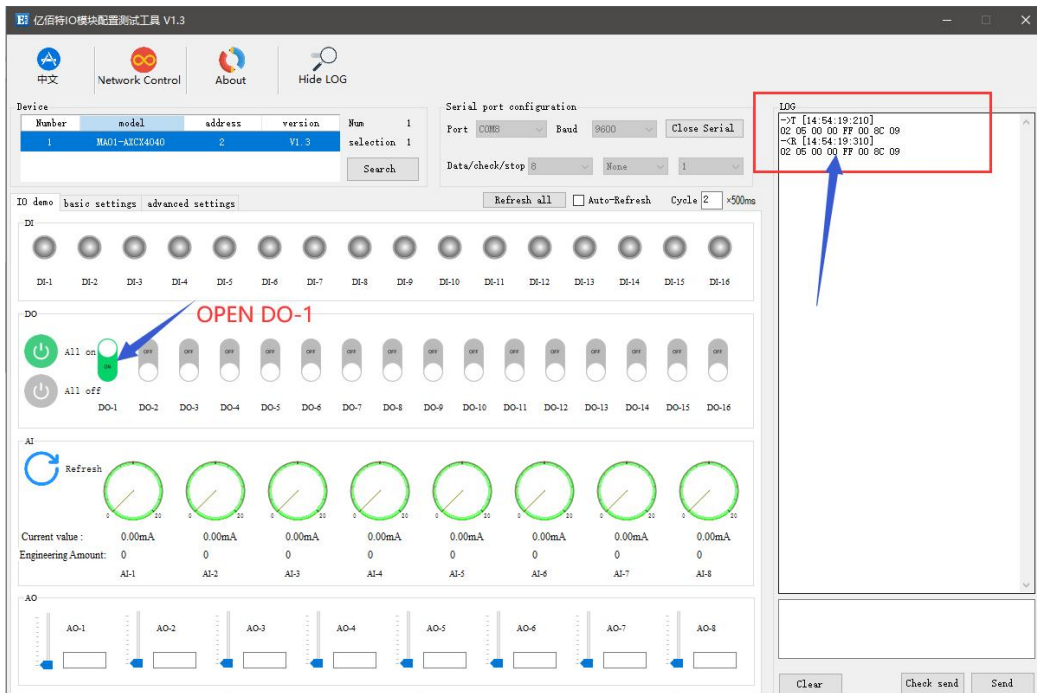

Figure 6-4-1 Software Graphic Operation

Method 2: Enter instruction control.

Device address:1

Function: Turn on the DO-1 output

Send:01 05 00 00 FF 00 8C 3A (with CRC check bit).

Return:01 05 00 00 FF 00 8C 3A (with CRC check bit).

7. Modbus Uses

7.1 Register List

Table 7-1-1 Register List

Register address	Number	The contents of the register	state	The range of data	The applicable function code
(00000)0x0000	4	Do status	RW	0x00-0xFF, write changes the current DO state, and read gets the current DO state.	0x01、0x05、0x0F
(00100)0x0064	4	The status of the DO when it is powered on	RW	0x00-0xFF, set the power-on state of the DO, write, and the next time you restart, the state of the DO is the state of the setting.	0x01、0x05、0x0F
(10000)0x0000	4	BY 值	RW	0x00-0xFF, which represents the current level signal for DI.	0x02
(41204)0x04B4	4	Di count value	RW	0x0001-0x0008, writes to represent the initial value of the set count, and read out the value that has been read out.	0x03、0x06、0x10
(41400)0x0578	4	DO mode of operation	RW	0x0000-0x0002, 0x0000 level mode (default mode), 0x0001 pulse mode, 0x0002 follow mode.	0x03、0x06、0x10
(41500)0x05DC	4	DO pulse width	RW	0x32-0xFFF (50-65535), duration of pulse, in ms.	0x03、0x06、0x10
(41318)0x0526	4	Di counting method	RW	0x0000-0x0002, 0x0000 represents the rising edge count, 0x0001 the falling edge count, 0x0002 the level count.	0x03、0x06、0x10
(41304)0x0518	4	How the DI count value is zeroed	RW	0x0000-0x0001, 0x0000 automatic zeroing and manual zeroing 0x0001.	0x03、0x06、0x10
(41311)0x051F	4	Set the zeroing method	RW	0x0001-0x00FF。	0x03、0x06、0x10
(41600)0x0640	4	Set the DO to follow the channel	RW	0x0001-0x0008, 0x0001 represents the first input.	0x03、0x06、0x10
(42000)0x07D0	7	Module model	R	See model definition table.	0x03
(42012)0x07DC	2	The firmware version	R	Firmware version number.	0x03
(42014)0x07DE	10	The name of the module	RW	The name is up to 20 bytes long, including ""	0x03、0x06、0x10
(42027)0X07E8	1	Module Software Address	RW	0x01-0xE0。	0x03、0x06、0x10
(42025)0X07E9	1	Restore the default parameters	RW	Write 5BB5 and the set parameters revert to the default parameters.	0x03、0x06、0x10
(42026)0x07EA	1	The device restarts	RW	Write 5BB5 and the device restarts immediately	0x03、0x06、0x10
(42100)0x0834	1	Baud rate code	RW	The default is 0x0003, or 9600. 0x0000, i.e. 1200; 0x0001, or 2400; 0x0002, or 4800;	0x03、0x06、0x10

				0x0003, or 9600; 0x0004, i.e. 19200; 0x0005, or 38400; 0x0006, or 57600; 0x0007, or 115200;	
(42102)0x0836	1	The way to check	RW	The default value is 0x0000, which is no check. 0x0000, i.e. no checks; 0x0001, i.e. odd check; 0x0002, i.e. parity;	0x03、0x06、0x10

7.2 List of AI-related registers

Table 7-2-1 List of AI-related registers

Register address	Number	The contents of the register	state	The range of data	The applicable function code
(30000)0x0000	4	The original value of the AI	R	0-4095	0x04
(30100)0x0064	4	AI engineering value	R	0-25000	0x04
(40400)0x0190	4	AI High Point Calibration value	RW	0-4095	0x03、0x06、0x10
(40600)0x0258	4	AI Low Calibration Value	RW	0-4095	0x03、0x06、0x10
(41200)0x04B0	1	All AI channel filter parameters	RW	1-16	0x03、0x06、0x10
(41202)0x04B2	1	All AI channel sampling ranges	RW	0x0000-0x0001, 0x0000 for 0-20mA and 0x0001 for 4-20mA.	0x03、0x06、0x10

7.3 Instruction format (partial).

7.3.1 Read DO output coil status

Use the 01 function code to read the output coil status, for example, read the two output coil states

20	01	00 00	00 02	XX XX
Device Modbus address	The function code	Register start address	The number of output coils read	CRC check code

When the above command is sent to the device via the 485 bus, the device returns the following values:

20	01	01	02	XX XX
Device Modbus address	The function code	The number of bytes of the data	The status data returned	CRC check code

The status data returned above 02 indicates that the output DO2 on .

7.3.2 Read Hold Register

Use the 03 function code to read one or more register values, for example, read DO1 operating mode.

20	03	05 78	00 01	XX XX
Device Modbus address	The function code	Register start address	The register to read quantity	CRC check code

When the above command is sent to the device via the 485 bus, the device returns the following values:

20	03	02	00 00	XX XX
Device Modbus address	The function code	The number of bytes of the data	The data returned	CRC check code

The above 00 00 indicates that DO1 is level mode.

7.3.3 Write a single hold register

Write a single hold register using the 06 function code, for example, set the operating mode of DO1 to pulse mode

20	06	05 78	00 01	XX XX
Device Modbus address	The function code	Register address	Write the value	CRC check code

When the above command is sent to the device via the 485 bus, the device returns the following values:

20	06	05 78	00 01	XX XX
Device Modbus address	The function code	Register address	Write the value	CRC check code

If the modification is successful, the 0x0578 register data is 0x0001.

7.3.4 Write multiple hold registers

Write multiple hold register commands using 10 function codes, for example, set the do1-DO4 operating mode at the sametime.

20	10	05 78	00 04	08	0001 0002	XX XX
Device Modbus address	The function code	Register start address	The number of registers	The number of bytes written to the data	The data written	CRC check code

When the above command is sent to the device via the 485 bus, the device returns the following values:

20	10	05 78	00 04	XX XX
Device Modbus address	The function code	Register address	The number of registers	CRC check code

If the modification is successful, the values of the four consecutive registers with 0x 0578 as the starting address are 0x0001, 0x0002, 0x0003, 0x0000.

7.3.5 Write a single DO coil status

Use the 05 command to write a single command, for example, to set do1 to pulse mode

20	05	00 00	FF 00	XX XX
Device Modbus address	The function code	Register address	Write the value Coil action: On	CRC check code

When the above command is sent to the device via the 485 bus, the device returns the following values:

20	05	00 00	FF 00	XX XX
Device Modbus address	The function code	Register address	Write the value	CRC check code

DO1 coil on.

7.3.6 Write multiple DO coil states

Use the 0F function code to write a single command, for example, set do1 to pulse mode

20	0F	00 00	00 04	01	06	XX XX
Device Modbus address	The function code	The starting address	The number of coils	The number of bytes of the data	Control the data for the coil (bit operation)	CRC check code

When the above command is sent to the device via the 485 bus, the device returns the following values:

20	0F	00 00	00 04	XX XX
Device Modbus address	The function code	Register address	The number of coils	CRC check code

DO2, DO3 coil on.

7.3.7 Read the input register

For example, the original value of the four AI channels is captured, and the original value of the four AI channels is read using the 04 function code.

20	04	00 00	00 04	XX XX
Device Modbus address	The function code	The starting address	The number of AI channels is 4	CRC check code

When the above command is sent to the device via the 485 bus, the device returns the following values:

20	04	08	00 00 00 00 00 00 00 00	XX XX
Device Modbus address	The function code	The data word The number of sections	4 AI channel raw value data, Each 2 bytes of data represents an AI channel data, where the original values for each channel are 0, 0, 0, 0	CRC check code

The final interpretation is owned by Chengdu Yiyit Electronic Technology Co., Ltd.

Revised history

version	The revision date	Revised description	Maintainer
1.0	2021-08-30	The initial version	LC
1.1	2022-06-27	Content revision	XXN

About us

Technical support: support@cdebyte.com

Documents and RF Setting download link: www.ebyte.com

Thank you for using Ebyte products! Please contact us with any questions or suggestions: info@cdebyte.com

Phone: +86 028-61399028

Web: www.ebyte.com

Address: B5 Mould Park, 199# Xiqu Ave, High-tech District, Sichuan, China

 **Chengdu Ebyte Electronic Technology Co.,Ltd.**