



## DC BRUSHLESS FAN

AF7D4012B 40\*40\*12mm

Motor:DC Brushless  
 Bearing:Ball、sleeve、Hydraulic  
 Shell frame: PBT UL94V-0  
 Fan blade: PBT UL94V-0  
 Insulation:Class B  
 Wire:AWG#26UL1007 (optional)  
 PIN1:BLACK WIRE----(-)  
 PIN2:RED WIRE----(+)



**DIMENSIONS DRAWING(unit:mm)**

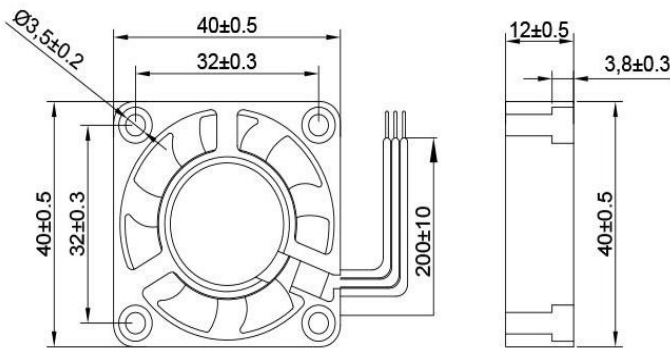

**P@Q CURVE(AT RATEDVOLTAGE)**

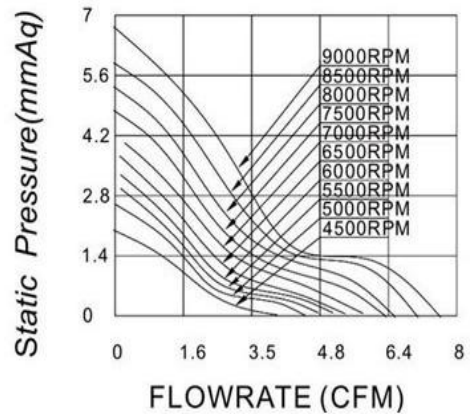

Model	Bearing Mode①	Rate d	Operating	Rated	Rated	Speed	Maximum		Maximum		Noise
		Volt	voltage	current	input		air Flow	Air	pressure	pressure	
PART. NO.		VDC	range	Amp	Walt	R. P. M	M3/min	CFM	mmH20	lnH20	dB-A
AF7D4012B05L	B=Ball S=Sleeve H=Hydraulic	5	1.8~3.6	0.072	0.36	4500	0.111	3.93	2.09	0.082	24.6
AF7D4012B05LV		5	1.8~3.6	0.096	0.48	5000	0.128	4.51	2.65	0.104	28.5
AF7D4012B05LM		5	1.8~3.6	0.12	0.60	5500	0.137	4.83	3.03	0.119	30.0
AF7D4012B05M		5	1.8~3.6	0.144	0.72	6000	0.146	5.16	3.43	0.135	31.0
AF7D4012B05ML		5	1.8~3.6	0.168	0.84	6500	0.152	5.35	3.81	0.15	33.4
AF7D4012B05H		5	1.8~3.6	0.19	0.96	7000	0.165	5.84	4.19	0.165	35.3
AF7D4012B05HL		5	1.8~3.6	0.22	1.08	7500	0.178	6.30	4.72	0.186	37.1

AF7D4012B05HH	B=Ball S=Sleeve H=Hydraulic	5	1.8~3.6	0.24	1.20	8000	0.184	6.51	5.26	0.207	38.0
AF7D4012B05VH		5	1.8~3.6	0.26	1.32	8500	0.199	7.02	5.92	0.233	39.5
AF7D4012B12L		12	8.5~13.5	0.03	0.36	4500	0.111	3.93	2.09	0.082	24.6
AF7D4012B12LV		12	8.5~13.5	0.04	0.48	5000	0.128	4.51	2.65	0.104	28.5
AF7D4012B12LM		12	8.5~13.5	0.05	0.60	5500	0.137	4.83	3.03	0.119	30.0
AF7D4012B12M		12	8.5~13.5	0.06	0.72	6000	0.146	5.16	3.43	0.135	31.0
AF7D4012B12ML		12	8.5~13.5	0.07	0.84	6500	0.152	5.35	3.81	0.15	33.4
AF7D4012B12H		12	8.5~13.5	0.08	0.96	7000	0.165	5.84	4.19	0.165	35.3
AF7D4012B12HL		12	8.5~13.5	0.09	1.08	7500	0.178	6.30	4.72	0.186	37.1
AF7D4012B12HH		12	8.5~13.5	0.1	1.20	8000	0.184	6.51	5.26	0.207	38.0
AF7D4012B12VH		12	8.5~13.5	0.11	1.32	8500	0.199	7.02	5.92	0.233	39.5

①Bearing Mode:Ball/ Sleeve/Hydraulic/Ball (UL)/Sleeve (UL)Hydraulic (UL)

②X=Function: FG RD RDL LD PWM TP VC RC CS RP SS AS CL IPX5

③A=Plug

④C=Customized by customers: Air volume, Air duct, Movement, Service life, Temperature, Noise, Material, Mold.etc.

导引: 编码规则Code Rule

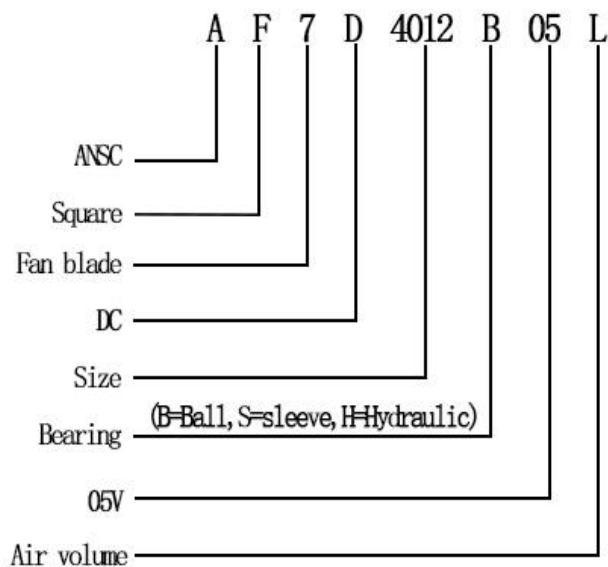

\*PROPRIETARY AND CONFIDENTIAL , THE INFORMATION CONTAINED IN THIS DRAWING IS THE SOLE PROPERTY OF <ALL NEW SEMI>. ANY REPRODUCTION IN PART OR AS A WHOLE WITHOUT THE WRITTEN PERMISSION OF <ALL NEW SEMI> IS PROHIBITED.

<https://allnewsemi.com>  
<https://allnewsemi.shop>