



DC BRUSHLESS FAN

AF9D4010B 40*40*10mm

Motor:DC Brushless
 Bearing:Ball、sleeve、Hydraulic
 Shell frame: PBT UL94V-0
 Fan blade: PBT UL94V-0
 Insulation:Class B
 Wire:AWG#26UL1007 (optional)
 PIN1:BLACK WIRE---(-)
 PIN2:RED WIRE---(+)



DIMENSIONS DRAWING(unit:mm)

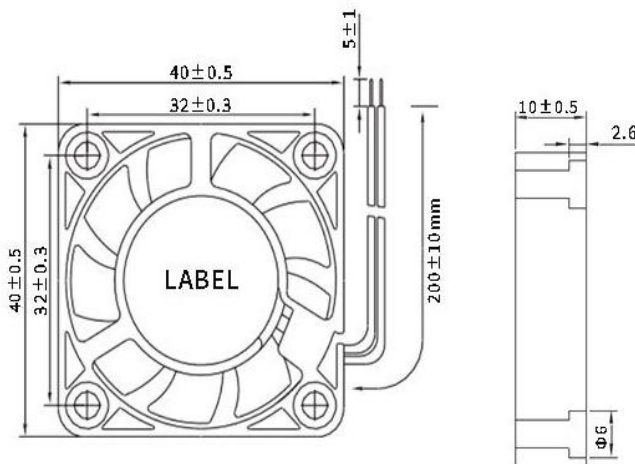

P@Q CURVE(AT RATED VOLTAGE)

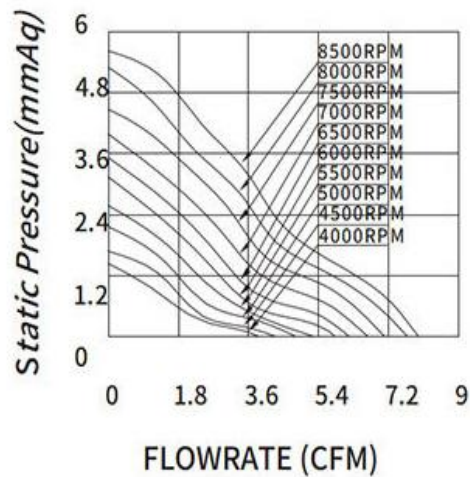

Model	Bearing Mode①	Rate d	Operating	Rated	Rated	Speed	Maximum		Maximum		Noise
		Volt	voltage	current	input		air Flow	Air	pressure	pressure	
PART. NO.		VDC	range	Amp	Watt	R. P. M	M3/min	CFM	mmH2O	InH2O	dB-A
AF9D4010B05L	B=Ball S=Sleeve H=Hydraulic	5	1.8~3.6	0.072	0.36	4500	0.122	4.31	1.71	0.067	24.2
AF9D4010B05LV		5	1.8~3.6	0.096	0.48	5000	0.136	4.81	2.21	0.087	27.3
AF9D4010B05LM		5	1.8~3.6	0.12	0.60	5500	0.148	5.23	2.54	0.1	29.2
AF9D4010B05M		5	1.8~3.6	0.144	0.72	6000	0.164	5.80	3.06	0.12	31.1
AF9D4010B05ML		5	1.8~3.6	0.168	0.84	6500	0.177	6.24	3.50	0.138	33.4
AF9D4010B05H		5	1.8~3.6	0.19	0.96	7000	0.187	6.59	3.91	0.154	35.1
AF9D4010B05HL		5	1.8~3.6	0.22	1.08	7500	0.201	7.10	4.51	0.178	37.1

AF9D4010B05HH	B=Ball S=Sleeve H=Hydraulic	5	1.8~3.6	0.24	1.20	8000	0.219	7.73	5.22	0.206	39.1
AF9D4010B05VH		5	1.8~3.6	0.26	1.32	8500	0.227	8.02	5.57	0.219	40.2
AF9D4010B12L		12	8.5~13.5	0.03	0.36	4500	0.122	4.31	1.71	0.067	24.2
AF9D4010B12LV		12	8.5~13.5	0.04	0.48	5000	0.136	4.81	2.21	0.087	27.3
AF9D4010B12LM		12	8.5~13.5	0.05	0.60	5500	0.148	5.23	2.54	0.1	29.2
AF9D4010B12M		12	8.5~13.5	0.06	0.72	6000	0.164	5.80	3.06	0.12	31.1
AF9D4010B12ML		12	8.5~13.5	0.07	0.84	6500	0.177	6.24	3.50	0.138	33.4
AF9D4010B12H		12	8.5~13.5	0.08	0.96	7000	0.187	6.59	3.91	0.154	35.1
AF9D4010B12HL		12	8.5~13.5	0.09	1.08	7500	0.201	7.10	4.51	0.178	37.1
AF9D4010B12HH		12	8.5~13.5	0.1	1.20	8000	0.219	7.73	5.22	0.206	39.1
AF9D4010B12VH		12	8.5~13.5	0.11	1.32	8500	0.227	8.02	5.57	0.219	40.2

①Bearing Mode:Ball/ Sleeve/Hydraulic/Ball (UL)/Sleeve (UL)Hydraulic (UL)

②X=Function: FG RD RDL LD PWM TP VC RC CS RP SS AS CL IPX5

③A=Plug

④C=Customized by customers: Air volume, Air duct, Movement, Service life, Temperature, Noise, Material, Mold.etc.

导引: 编码规则Code Rule

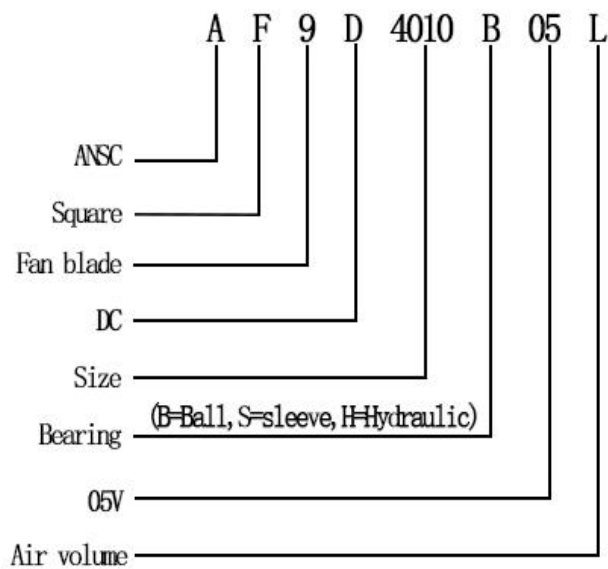

*PROPRIETARY AND CONFIDENTIAL , THE INFORMATION CONTAINED IN THIS DRAWING IS THE SOLE PROPERTY OF <ALL NEW SEMI>. ANY REPRODUCTION IN PART OR AS A WHOLE WITHOUT THE WRITTEN PERMISSION OF <ALL NEW SEMI> IS PROHIBITED.

<https://allnewsemi.com>
<https://allnewsemi.shop>