



## EC Brushless FAN

AF5E15050B 150\*150\*50MM

Motor: EC Brushless  
 Bearing: Ball, sleeve, Hydraulic  
 Shell frame: PBT UL94V\_0  
 Fan blade: PBT UL94V\_0  
 Insulation: Class B  
 Wire: AWG#26UL1007 (optional)  
 PIN1: BLACK WIRE---(-)  
 PIN2: RED WIRE---(+)



DIMENSIONS DRAWING(unit:mm)

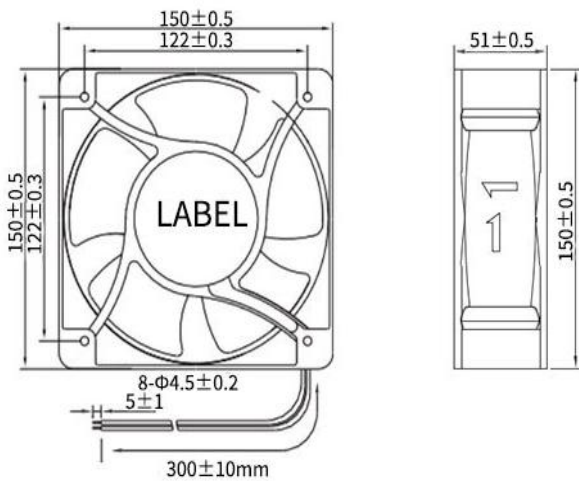

P@Q CURVE(AT RATED VOLTAGE)

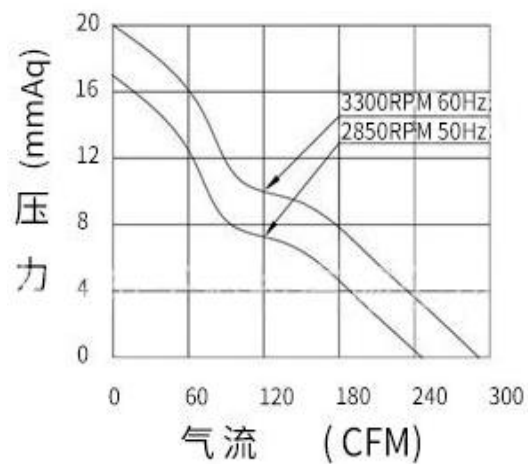

| Model          | Bearing Mode①                     | Rated Vol | Frequency | Rated current | Rated input power | Speed   | Maximum air Flow |        | Maximum Air pressure |       | Noise |
|----------------|-----------------------------------|-----------|-----------|---------------|-------------------|---------|------------------|--------|----------------------|-------|-------|
|                |                                   | VDC       | VDC       | Amp           | Watt              |         | R. P. M          | M3/min | CFM                  | mmH2O |       |
| PART. NO.      |                                   | VDC       | VDC       | Amp           | Watt              | R. P. M | M3/min           | CFM    | mmH2O                | InH2O | dB-A  |
| AF5E15050B220L | B=Ball<br>S=Sleeve<br>H=Hydraulic | 220       | 80~230    | 0.1           | 22                | 2500    | 4.877            | 172.21 | 10.92                | 0.43  | 56.1  |
| AF5E15050B220M |                                   | 220       | 80~230    | 0.14          | 30.8              | 3000    | 5.93             | 209.4  | 15.33                | 0.604 | 58.3  |
| AF5E15050B220H |                                   | 220       | 80~230    | 0.18          | 39.6              | 3500    | 7.026            | 248.09 | 21.33                | 0.84  | 62.5  |
| AF5E15050B220H |                                   | 220       | 80~230    | 0.22          | 48.4              | 4000    | 8.015            | 283    | 27.36                | 1.077 | 65.5  |
| AF5E15050B220V |                                   | 220       | 80~230    | 0.3           | 66                | 4500    | 9.22             | 325.57 | 37.57                | 1.479 | 68.2  |
| AF5E15050B220H |                                   | 220       | 80~230    | 0.35          | 77                | 5000    | 10.243           | 361.69 | 45.36                | 1.876 | 71.4  |

① Bearing Mode: Ball/ Sleeve/ Hydraulic/ Ball (UL) / Sleeve (UL) Hydraulic (UL)

② X=Function: FG RD RDL LD PWM TP VC RC CS RP SS AS CL IPX5

③ A=Plug

④ C=Customized by customers: Air volume, Air duct, Movement, Service life, Temperature, Noise, Material, Mold. etc.

导引: 编码规则 Code Rule

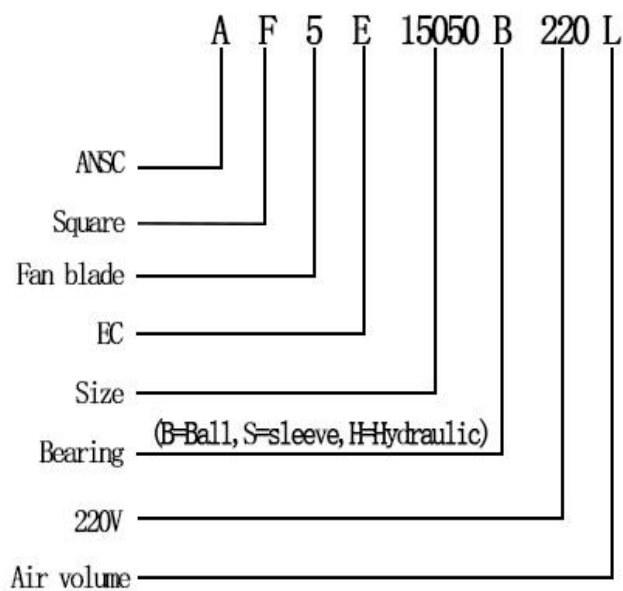

\*PROPRIETARY AND CONFIDENTIAL , THE INFORMATION CONTAINED IN THIS DRAWING IS THE SOLE PROPERTY OF <ALL NEW SEMI>.

ANY REPRODUCTION IN PART OR AS A WHOLE WITHOUT THE WRITTEN PERMISSION OF <ALL NEW SEMI> IS PROHIBITED.

<https://allnewsemi.com>  
<https://allnewsemi.shop>