



DC BLOWER FAN

AG5010B 50*50*10mm

Motor:DC Blower
 Bearing:Ball、Sleeve、Hydraulic
 Shell frame: PBT UL94V_0
 Fan blade: PBT UL94V_0
 Insulation:Class B
 Wire:AWG#26UL1007 (optional)
 PIN1:BLACK WIRE---(-)
 PIN2:RED WIRE---(+)



DIMENSIONS DRAWING(unit:mm)

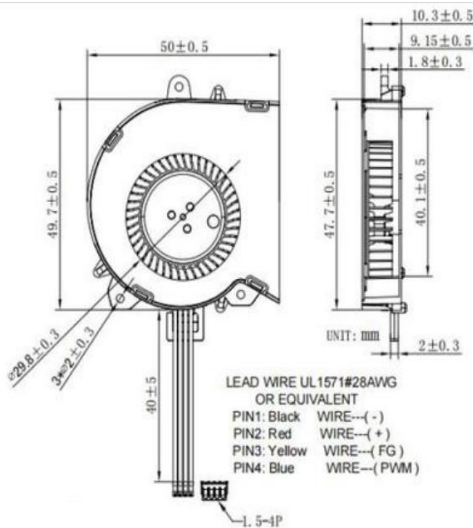

P@Q CURVE(AT RATED VOLTAGE)

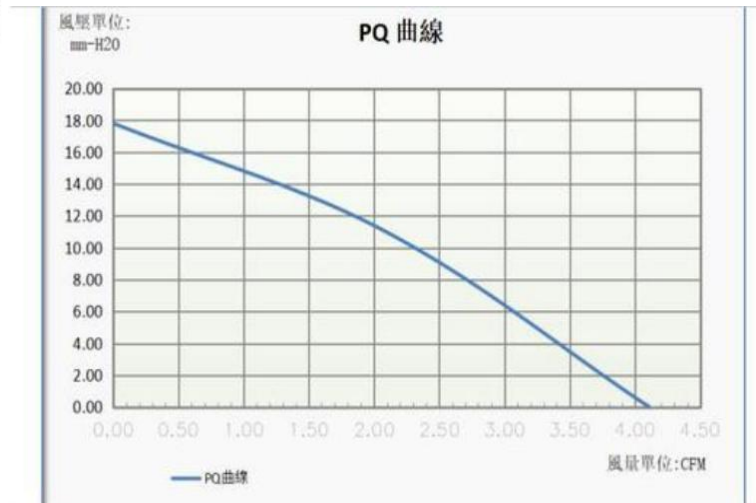

Model	Bearing Mode①	Rated Voltage	Operating voltage range	Rated current	Rated input power	Speed	Maximum air Flow		Maximum Air pressure		Noise
PART. NO.		VDC	VDC	Amp	Watt	R. P. M	m ³ /min	CFM	mmH2O	InH2O	dB-A
AG5010B05H	B=Ball S=Sleeve H=Hydraulic	5	3.6~6	0.25	1.25	5300	0.09	3.31	6.66	0.26	33.3
AG5010B05HH		5	3.6~6	0.36	1.8	7000	0.12	4.11	17.81	0.70	38.8
AG5010B12H		12	9~15	0.12	1.25	5300	0.09	3.31	6.66	0.26	33.3
AG5010B12HH		12	9~15	0.15	1.8	7000	0.12	4.11	17.81	0.70	38.8

①Bearing Mode:Ball/ Sleeve/Hydraulic/Ball (UL)/Sleeve(UL)Hydraulic (UL)

②X=Function: FG RD RDL LD PWM TP VC RC CS RP SS AS CL IPX5

③A=Plug

④C=Customized by customers: Air volume, Air duct, Movement, Service life, Temperature, Noise, Material, Mold. etc.

导引： 编码规则Code Rule

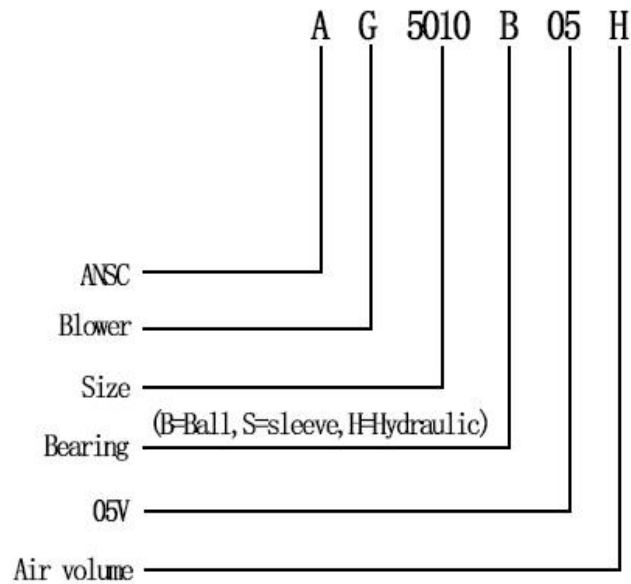

*PROPRIETARY AND CONFIDENTIAL , THE INFORMATION CONTAINED IN THIS DRAWING IS THE SOLE PROPERTY OF <ALL NEW SEMI>.
ANY REPRODUCTION IN PART OR AS A WHOLE WITHOUT THE WRITTEN PERMISSION OF <ALL NEW SEMI> IS PROHIBITED.

<https://allnewsemi.com>
<https://allnewsemi.shop>