



Chengdu Ebyte Electronic Technology Co.,Ltd

Wireless Modem

User Manual



All rights to interpret and modify this manual belong to
Chengdu Ebyte Electronic Technology Co., Ltd.

Contents

1. Product Overview.....	3
1.1 Introduction.....	3
2. Parameter.....	3
2.1 General parameter.....	3
2.2 Wireless parameter.....	4
2.3 Dimension and pin definition.....	5
2.4 Connection method.....	6
3 Product function.....	7
3.1 Basic function.....	7
3.1.1 SOCKET.....	7
3.1.2 TCP Client.....	7
3.1.3 TCP Server.....	7
3.1.4 UDP Client.....	8
3.1.5 UDP Server.....	9
3.1.6 WOR role.....	9
3.1.7 Fixed point transmission.....	9
3.1.8 Broadcasting and Monitoring.....	10
3.1.9 Communication key.....	10
3.1.10 Enable repeater.....	10
3.1.11 Enable LBT.....	10
3.1.12 Enable RSSI byte.....	10
3.1.13 Enable RSSI environment noise.....	10
3.2 Featured function.....	11
3.2.1 web page configuration.....	11
3.2.2 Heartbeat function.....	11
3.2.3 Registration package function.....	12
3.2.5 Short connection function.....	12
3.2.6 KeepAlive function.....	13
3.2.7 Timeout restart function.....	13
3.2.8 Clearing the cache function.....	13
3.2.9 Link/ data transmission indication.....	13
3.2.10 Restore to factory setting.....	14
4 Quick Start.....	14
4.1 Default parameter.....	14
4.2 SOCKET instruction.....	15
4.3 TCP Client guidance.....	15
4.4 TCP Server guidance.....	16
4.5 UDP Client guidance.....	18
4.6 UDP Server guidance.....	19
4.7 WEB introduction.....	21
Revision history.....	23
About us.....	23

1. Product Overview

1.1 Introduction

The E90-DTU (900SL22-ETH) supports adaptive network speed (up to 100M full-duplex) and provides four working modes: TCP Server, TPC Client, UDP Server, and UDP Client. It also supports two-way SOCKET work. The wireless communication adopts LoRa direct sequence spread spectrum technology, which will bring longer communication distance and has the advantages of concentrated power density and strong anti-interference ability. It has a software FEC forward error correction algorithm, which has high coding efficiency and strong error correction capability. In the case of sudden interference, it can actively correct the interfered data packets, greatly improving reliability and transmission distance, and helping users to efficiently Complete transparent transmission of long-distance data. Users can configure it through the WEB webpage.

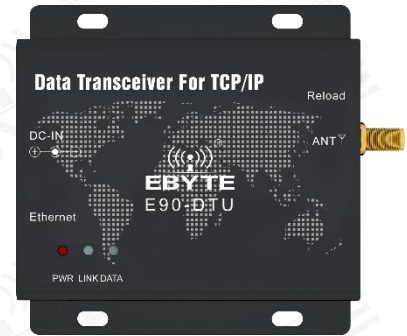

2. Parameter

2.1 General parameter

No	Item	Specification
1	Power supply	8V~28VDC, will burn over 28V, 12V or 24V is recommended
2	Ethernet specification	RJ45, support 10/100Mbps
3	Network protocol	IP、 TCP/UDP、 ARP、 ICMP、 IPV4
4	Simple transparent transmission	TCP Server、 TCP Client、 UDP Server、 UDP Client
5	TCP Server connection	Max of 6 channel TCP connection
6	IP acquisition method	Static IP、 DHCP
7	DNS	Available
8	Configured by user	Web page configuration
9	Antenna interface	SMA
10	Operating temperature	-40 ~ +85°C
11	Operating humidity	10% ~ 90%, Relative humidity, no condensation
12	Size	84mm*82mm*25mm
13	Average weight	130g
15	Storage temperature	-40~+125°C

2.2 Wireless parameter

Main parameter		Performance			Remark
		Min.	Typ.	Max.	
Blocking power (dBm)		-	-	10	Chances of burn is slim when modules are used in short distance
Frequency (MHz)		850.125		930.125	ISM band
Power consumption	TX current (mA)		142.9mA@12V		Instant power consumption
	RX current (mA)		70.4mA@12V		
Max tx power (dBm)		21.5	22.0	22.5	
Receiving sensitivity (dBm)		-147	-148	-149	Air data rate 0.3 kbps
Air data rate (bps)		0.3k	2.4k	62.5k	Configured by user
Distance		5000m			In open and clear air, antenna gain 5dBi, at height of 2.5 m, air data rate 2.4 kbps
Transmission length		240 Byte			Can be set as 32/64/128/240 bytes each packet
Receiving length		1000 Byte			—
Modulation method		New generation LoRa			—

2.3 Dimension and pin definition

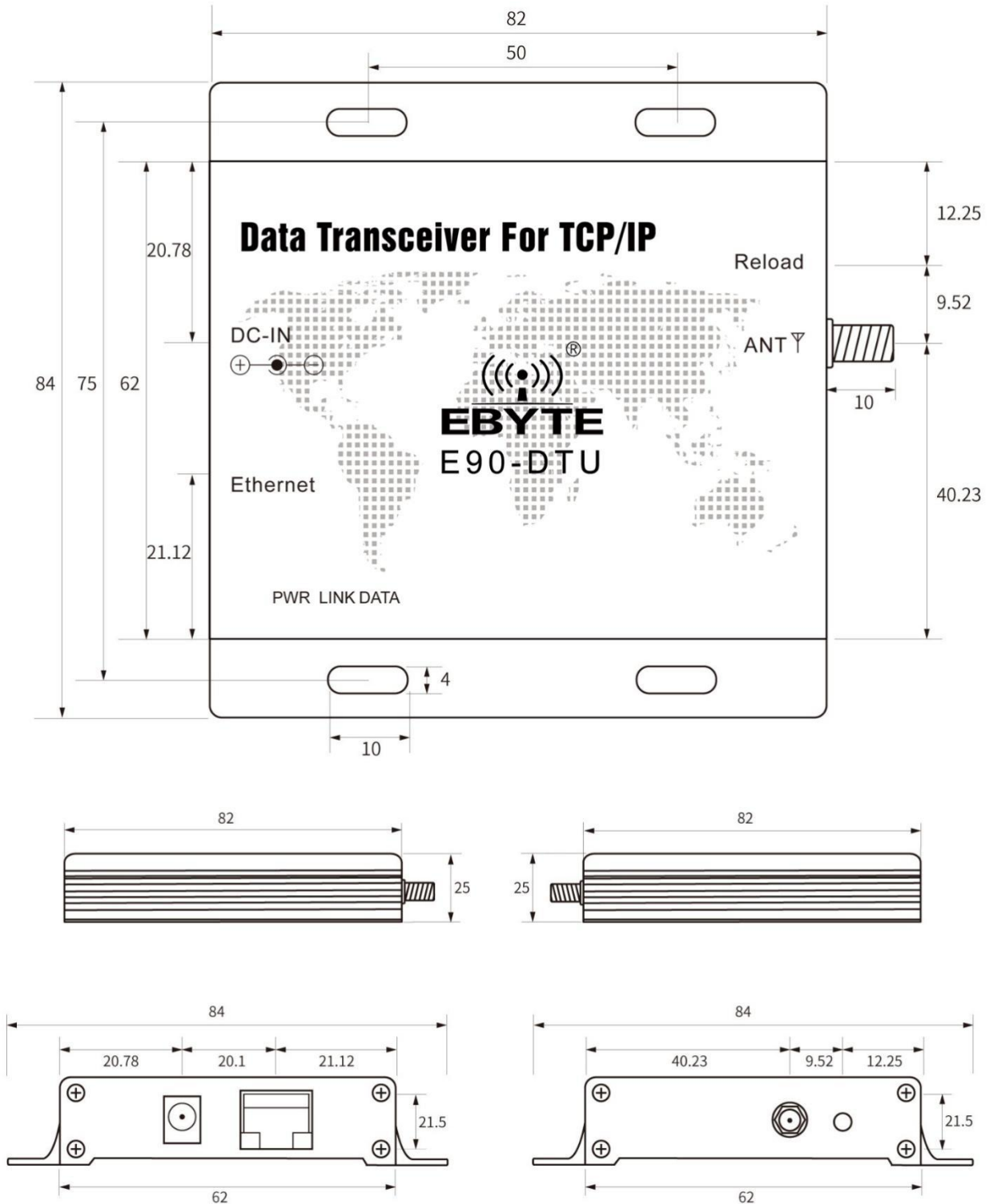

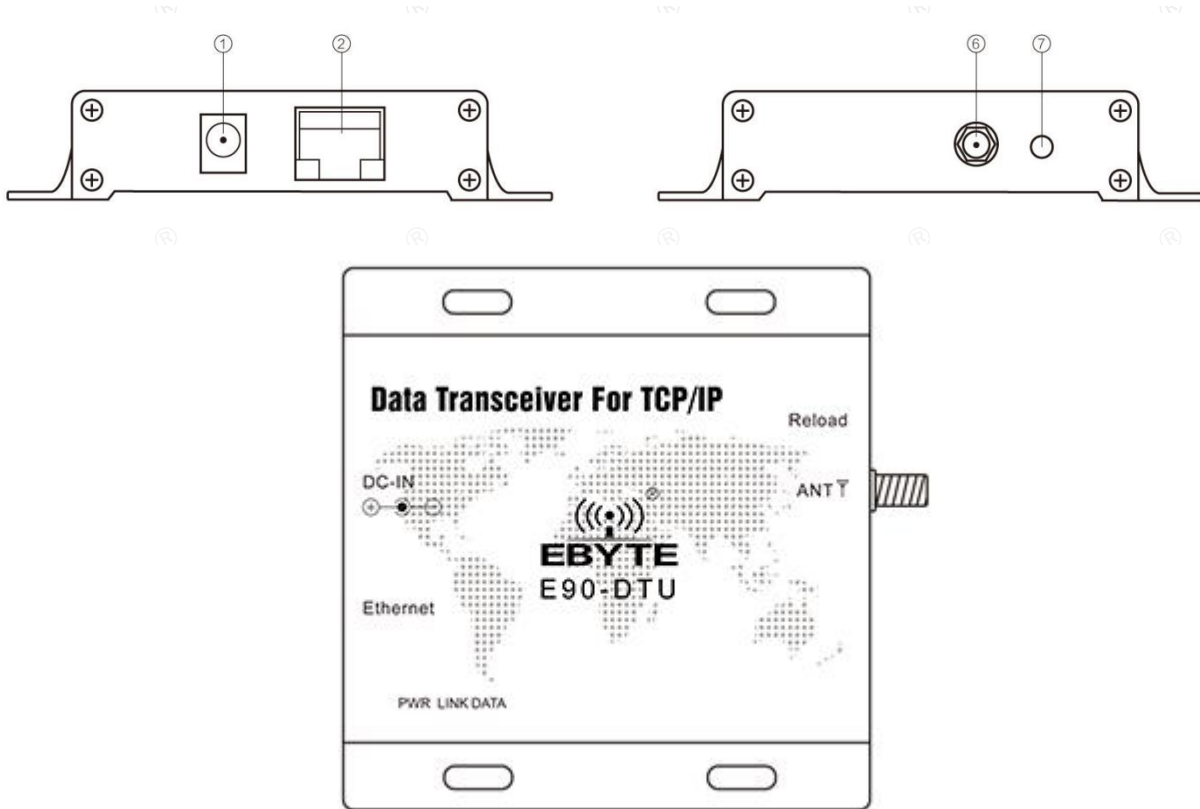

No.	Name	Specification
1	DC-IN	Power supply , default 8-28V (5V can be customized) , recommend 12V/24V
2	ETHERNET	RJ45 , to connect to PC or other device
3	PWR	Power indicator
4	LINK	Connection indicator
5	DATA	Serial port TX and RX indicator
6	Reload	Restore to factory setting
7	ANT	SMA

2.4 Connection method

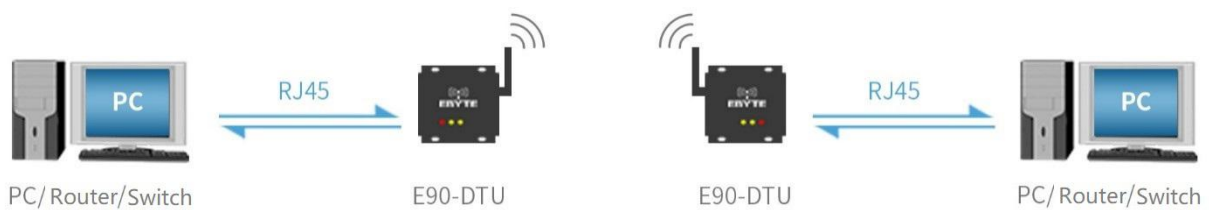

3 Product function

3.1 Basic function

→Ethernet

3.1.1 SOCKET

E90-DTU-(900SL22-ETH) can establish two Sockets, namely Socket A1 and Socket B1. Among them, Socket A1 supports TCP Client, TCP Server, UDP Client, and UDP Server. Socket B1 only supports TCP Client, UDP Client, and UDP Server.

Two Sockets run simultaneously. It can be connected to different networks at the same time for data transmission.

3.1.2 TCP Client

(1) The TCP Client provides a client connection for the TCP network service. Proactively initiate a connection request to the server and establish a connection for interaction between the wireless data and the server data. According to the relevant provisions of the TCP protocol, the TCP Client has the difference of connection and disconnection, thereby ensuring reliable exchange of data. It is commonly used for data interaction between devices and servers and is the most commonly used method of networked communication.

(2) E90-DTU-(900SL22-ETH) When attempting to connect to the server in TCP Client mode and the local port is 0, the connection is initiated with a random port each time.

(3) E90-DTU-(900SL22-ETH) supports short connection function.

(4) Under the same LAN, if E90-DTU-(900SL22-ETH) is set to static IP, please keep the IP and gateway of E90-DTU-(900SL22-ETH) on the same network segment, and set the gateway IP correctly, otherwise Will not communicate properly.



3.1.3 TCP Server

(1) TCP Server is a TCP server. In TCP Server mode, E90-DTU-(900SL22-ETH) listens to the local port, accepts and establishes connection for data communication when the connection request is sent. When E90-DTU-(900SL22-ETH) receives the data, it will be Send data to all client devices that are connected to the E90-DTU-(900SL22-ETH.)

(2) Usually used for communication with TCP clients in the LAN. It is suitable for scenarios where there is no server in the LAN and there are multiple computers or mobile phones requesting data from the server. As with TCP Client, there is a difference between

connection and disconnection to ensure reliable exchange of data.

(3) When E90-DTU-(900SL22-ETH) is used as TCP Server, it can accept up to 6 Client connections (the number of connections can be customized). The local port number is a fixed value and cannot be set to 0.

(4) TCP Server can set the maximum number of connections. When the maximum number of connections is reached, you can choose to kick off the old connection or disable the new connection function according to the command configuration.

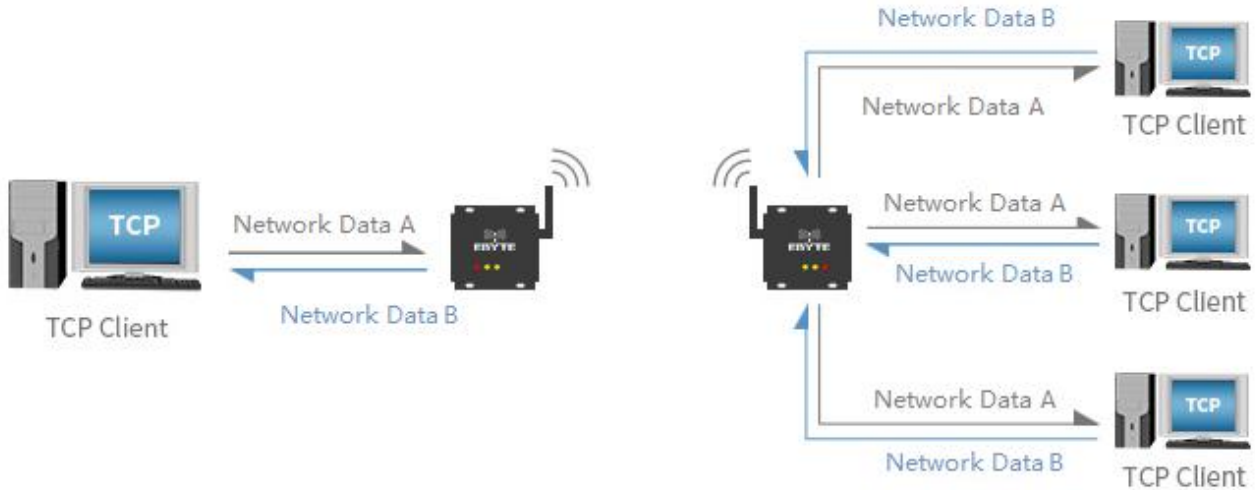

3.1.4 UDP Client

(1) UDP Client A connectionless transmission protocol that provides a transaction-oriented simple and unreliable information transmission service. Without the establishment and disconnection of a connection, only the IP and port need to be established to send data to the other party. It is usually used for data transmission scenarios where the packet loss rate is not required, the data packet is small and the transmission frequency is fast, and the data is transmitted to the specified IP.

(2) In UDP Client mode, E90-DTU-(900SL22-ETH) will only communicate with the target port of the target IP. If the data is not from this channel, the data will not be received by E90-DTU-(900SL22-ETH).

(3) In the UDP client mode, the destination address is set to 255.255.255.255, which can achieve the effect of UDP full network segment broadcast, and can also receive broadcast data. The E90-DTU-(900SL22-ETH) module supports the support network segment Broadcast, such as xxx.xxx.xxx.255 broadcast mode.

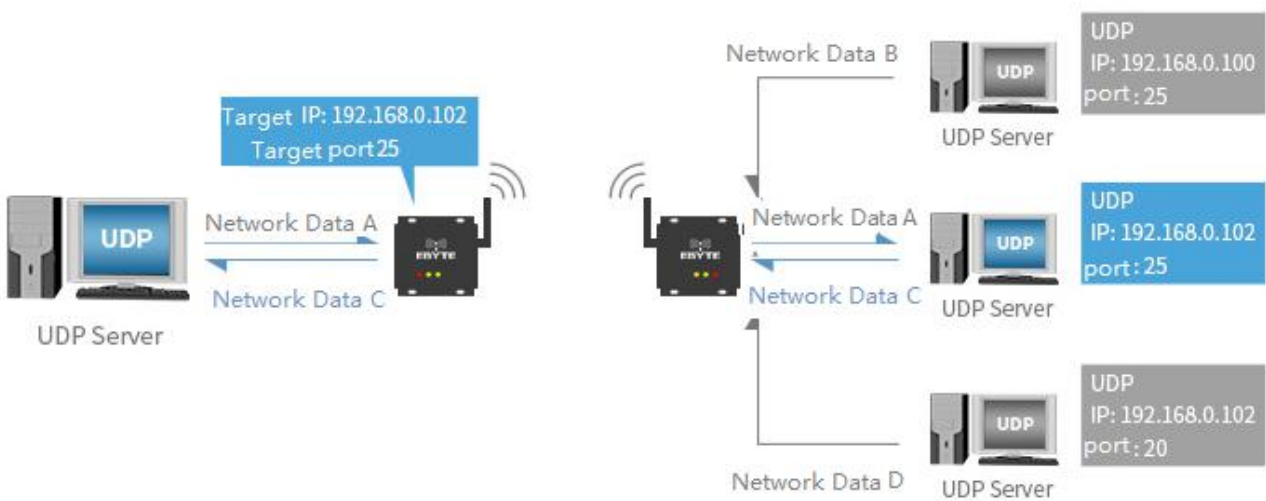

3.1.5 UDP Server

(1) UDP Server means that the source IP address is not verified on the basis of ordinary UDP. After receiving a UDP packet, the target IP is changed to the data source IP and port number. When the data is sent, the latest communication is sent. That IP and port number.

(2) This mode is usually used for data transmission scenarios where multiple network devices need to communicate with the module and do not want to use TCP due to faster speed.

Note: UDP Server cannot send data actively, and can only send data to the IP and port that has recently performed data interaction after receiving the data.

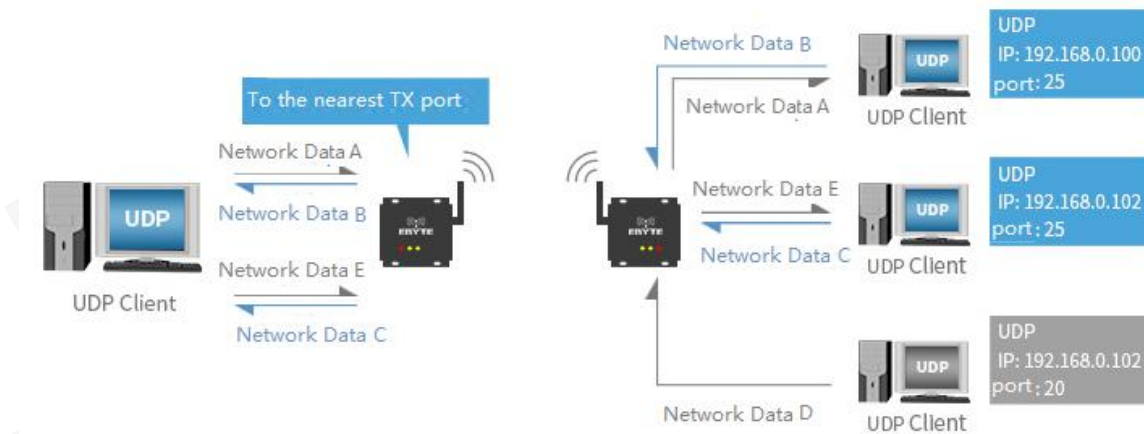

→Wireless

3.1.6 WOR role

(1) WOR is closed. The DTU works in the transmission mode, and the data input by the user through the Ethernet, the DTU will initiate wireless transmission. The wireless receiving function is turned on, and the wireless data is received and output through the Ethernet.

(2) WOR transmitter. The DTU is sent and received, and when the data is transmitted, a wake-up code is added for a certain period of time.

(3) WOR receiver. The DTU cannot transmit data, works in the WOR listening mode, and the listening period is selected on the web side. The longer the WOR listening interval period,

The lower the average power consumption, but the greater the data delay, the two sides must be consistent (very important).

3.1.7 Fixed point transmission

It supports address function, the master can transmit data to any address, any channel module, to achieve networking, relay and other application methods: for example: module A needs to send data to module B (address is 0x00 01, channel is 0x80) AA BB CC The communication format is: 00 01 80 AA BB CC, where 00 01 is the module B address and 80 is the module B channel, then module B can receive the AA BB CC (other modules do not receive data).

3.1.8 Broadcasting and Monitoring

Set the DTU radio address to 0xFFFF: It can monitor the data transmission of the module on the same channel; the transmitted data can be received by the module at any address on the same channel, thus playing the role of broadcasting and monitoring.

3.1.9 Communication key

Only write is allowed, the web end always displays 0x0000, and the communication key is used for user encryption to avoid intercepting airborne wireless data by similar modules. The DTU internally uses these two bytes as a calculation factor to transform and encrypt the over-the-air wireless signal.

3.1.10 Enable repeater

After the repeater is enabled, if the target address is not the module itself, the module will initiate a forward. In order to prevent data backhaul, it is recommended to use it in conjunction with the fixed point mode. That is: the destination address is different from the source address.

3.1.11 Enable LBT

The DTU has a Listen before talk (LBT) function. When this function is enabled, the channel environment noise will be actively monitored before the wireless data is transmitted. If the noise exceeds the threshold, the transmission will be delayed. This function can greatly improve the communication success rate of the DTU in harsh environments. It can be used for network transmission, anti-collision processing, but may bring data delay, LBT maximum dwell time 2 seconds

3.1.12 Enable RSSI byte

It is the signal strength indication function. When enabled, the STU wirelessly receives the data and will follow an RSSI strength byte. It can be used to evaluate signal quality, improve communication networks, and range, and can be used to manually implement LBT functions.

3.1.13 Enable RSSI environment noise

When enabled, the C0 C1 C2 C3 instruction can be used to read the register in transfer mode or WOR transmit mode.

- Register 0x00 : current rssi of environment noise
- Register 0x01 : rssi for receiving data last time (current channel noise is: $\text{dBm} = -\text{RSSI}/2$)
- Command format: C0 C1 C2 C3 + starting address + read length
- Return: C1 + address address+read length+read valid value; for example: send C0 C1 C2 C3 00 01
- Return C1 00 01 rssi

3.2 Featured function

3.2.1 web page configuration

The DTU can be accessed through a browser to configure the web page. The access terminal and the module are in the same local area network when users visit the web. After entering 192.168.4.101, the user name and password, the web configuration page is entered.



Ebyte IOT
-www.ebyte.com-

Ebyte IOT application specialist

Current State	Parameter	Helpful Tips
IP Setting	Type: E90-DTU(900SL30-ETH)	<ul style="list-style-type: none"> SN code: SN code refers to the serial number of the device when the module is registered on Ebyte cloud platform. Connection status: Connection status refers to the real-time identification of whether the current SOCKET A/B is connected in the network.
Parameter Setting	Version: V1.1	
Advanced Setting	Current IP Address: 192.168.4.101	
Management	Mac Address: B2:F7:E2:EF:F4:1B	
	SN Code: 190829161127D8AF	
	Socket A connection: Disconnect	
	Socket B connection: Disconnect	

Copyright ? 2018 Chengdu Ebyte Electronic Technology Co., Ltd. All Right Reserved official website: www.ebyte.com

3.2.2 Heartbeat function

In the network transparent transmission mode, heartbeat packet can be sent by E90-DTU-(900SL22-ETH). The heartbeat packet can be sent to the web server. The main purpose is to maintain a connection with the server, which only takes effect in the TCP Client and UDP Client modes. The E90-DTU-(s) module supports up to 40 bytes of custom heartbeat packets.

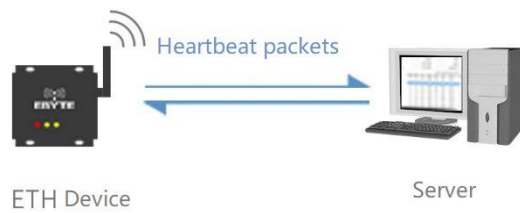

3.2.3 Registration package function

In network transparent transmission mode, the user can use the DTU to send a registration packet to the server. The registration package is for the server to recognize the data source device or to obtain a password for the server function authorization. The registration packet can be sent when the DTU establishes a connection with the server, or it can be spliced into the registration packet data at the forefront of each packet as a data packet. The data of the registration package can be a MAC address or a custom registration data, wherein the custom registration package setting content is up to 40 bytes.

Establishing a connection by sending a registration package is mainly used to connect servers that need to be registered.

Data carrying registration package: The sending data accesses the registration package at the front end of the data, and is mainly used for protocol transmission.

The registration package mechanism is only available for TCP Client and UDP Client, not valid under TCP Server and UDP Server.

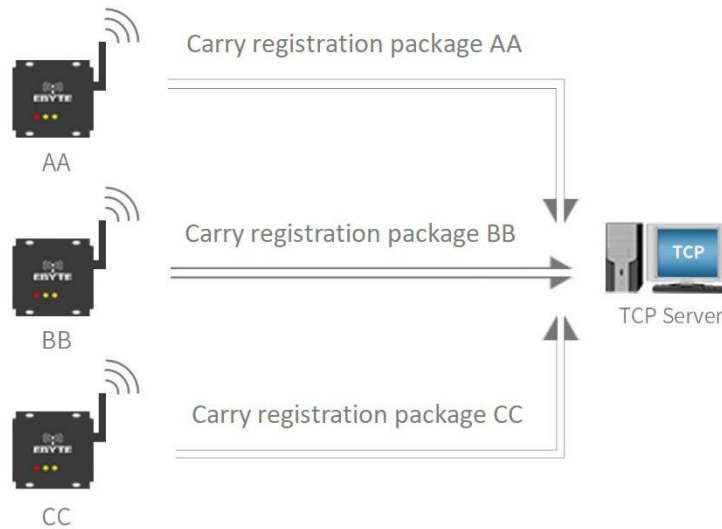

3.2.5 Short connection function

The use of TCP short connections is mainly to save server resources, and is generally applied to a multi-point scenario. With short connections, you can ensure that the existing connections are useful connections and do not require additional controls for filtering.

The TCP short connection function is applied to the TCP Client mode. After the short connection function is enabled, the message is sent. If there is no data reception in the serial port or network port within the set time, the connection will be automatically disconnected. The short connection function is turned off by default, and the disconnection time can be set after the function is turned on. The setting range is 2~255S.

3.2.6 KeepAlive function

Keep-Alive is the mechanism for detecting dead connections in a TCP connection. When the user does not send any data, the "Keep-Alive" information is periodically sent on the TCP link to maintain the idle link, avoiding dead connections and consuming unnecessary system resources. This setting is valid under TCP. Users can customize the Keep-Alive switch and other parameters.

keepalive parameter introduction:

- time:** How many seconds after the TCP link does not receive data packet transmission to start the probe packet;
- intv:** Time interval between the previous probe packet and the next probe packet;
- probes:** The maximum number of probe failures. When the sniffing fails to this number, the TCP connection will be disconnected.

3.2.7 Timeout restart function

The timeout restart (no data restart) function is mainly used to ensure that the E90-DTU-(900SL22-ETH) works stably for a long time. When the network port does not receive data for a long time, or the network does not receive data for a long time, E90-DTU-(The 900SL22-ETH) will restart after the set time has elapsed to avoid anomalies affecting communication. The timeout timeout can be set through the webpage. The normal working time of this function is set to 60~65535S, and the default value is 3600S. 0 is off, when the setting is out of range, it returns to the default value.

3.2.8 Clearing the cache function

When the TCP connection is not established, the data received by the DTU will be placed in the buffer area. The E90-DTU-(900SL22-ETH) receive buffer is 2Kbyte. When the TCP connection is established, the network cache data can be set or not according to customer requirements.

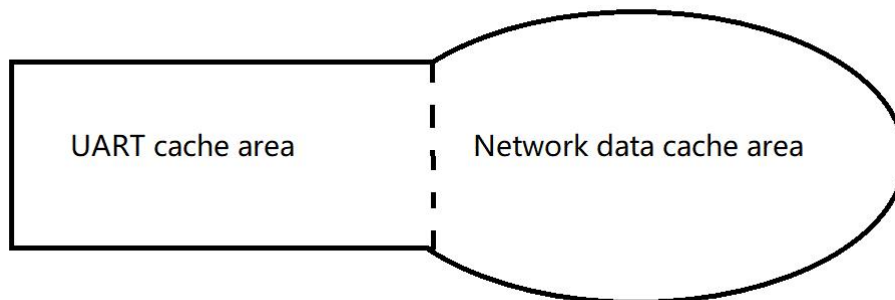

The device has two buffer areas, which are the serial data buffer and the network data buffer. When the SOCKET clear cache function is enabled, only the cache data of the relevant SOCKET link will be cleared, and the serial cache data will not be cleared.

3.2.9 Link/ data transmission indication

Link indicates the status of the network connection. In TCP mode, when the network is not connected, the Link is off, and when the connection is established, the Link is always on. The Link indicator is always on in UDP mode.

The other one is the data transmission indication, showing the transmission status of the DTU. When there is no data transmission on the DTU, the data transmission indicator is off. When there is data transmission on the DTU, the flashing indicates that the period is

60ms and the indicator is on for 10ms.

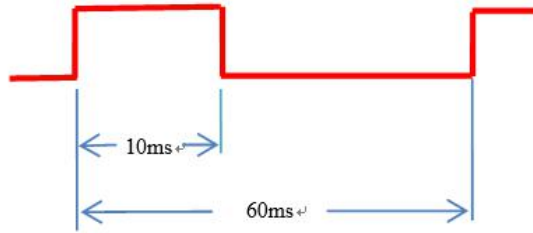

3.2.10 Restore to factory setting

The DTU is restored to the factory settings either by software or by button.

4 Quick Start

4.1 Default parameter

IP acquisition type	STATIC
IP address	192.168.4.101
Subnet mask	255.255.255.0
Gateway	192.168.4.1
DNS	61.139.2.69
Spared NDS	192.168.4.1
Socket A1 basic parameter	TCPS,192.168.4.101,8886
Socket A1 heartbeat package mode	NET
Socket A1 heartbeat package content	0 (s) , turn off heartbeat
Socket A1 register package mode	heartbeat msg
Socket A1 register package time	Turn off
Socket A1 register package content	regist msg
Socket A1 short connection time	0 (s) , turn off short connection
Socket A1 keepalive parameter	time/inteval/probes = 10 (s) /5 (s) /30 (times)
Socket A1 clear the cache	OFF
Socket B1 basic parameter	TCPC,192.168.4.100,8887
Socket B1 heartbeat mode	NET
Socket B1 heartbeat package time	0 (s) , turn off heartbeat
Socket B1 heartbeat package content	heartbeat msg
Socket B1 register package mode	Turn off
Socket B1 register package content	regist msg
Socket B1 short connection time	0 (s) , turn off short connection

Socket B1 keepalive parameter	time/inteval/probes = 10 (s) /5 (s) /30 (times)
Socket B1 clear the cache	OFF
Tcp server max connection number	6 (number)
Intranet discovery port	1901
Intranet discovery command	www.cdebyte.comwww.cdebyte.com
Web page port	80
Web login user name/password	admin/admin
Overtime resetting time	3600 (s)

4.2 SOCKET instruction

Preparation:

1. Set the IP address of the PC to the same network segment as E90-DTU (SL), and the subnet mask is the same. For example, the IP of the PC is 192.168.4.100, and the IP of the module is 192.168.4.101.;

4.3 TCP Client guidance

1. Open “Network Debugging Assistant” on Computer A and Computer B, set the protocol type to TCP Server, and set the local IP and port to 192.168.4.100 and 8886 respectively.

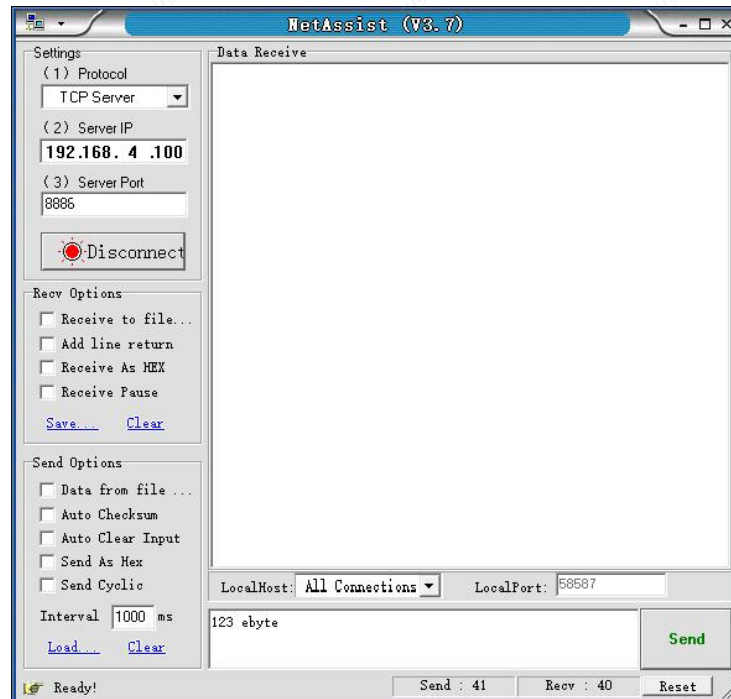

2. Set the SOCKET A1 network type of device A and device B to TCP Client, the destination IP address is 192.168.4.100, the local port 0 (random port), and the destination port 8886. Click Save to restart the module.

Socket A	Parameter
Work mode:	TCP Client
Remote server address or domain name:	192.168.4.100
Local/remote port:	0 8886 (0~65535)
Clear cache function:	<input type="checkbox"/>
Short link break time:	0 (0 close,2~65535)s
Heartbeat packet type:	network heartbeat packet
Heartbeat packet content:	heartbeat msg
	HEX: <input type="checkbox"/> ASCII: <input checked="" type="checkbox"/>
Heartbeat packet time:	0 (0 close,2~65535)s
Registered package type:	registration packet closure
Keep alive connections:	<input checked="" type="checkbox"/>
Detection time:	10 (0 close,2~7200)s
Detection of interval:	5 (2~7200) s
Number of detection:	30 (2~255)times

3、 The DTU is connected via Network Debugging Assistant for communication test as shown below.

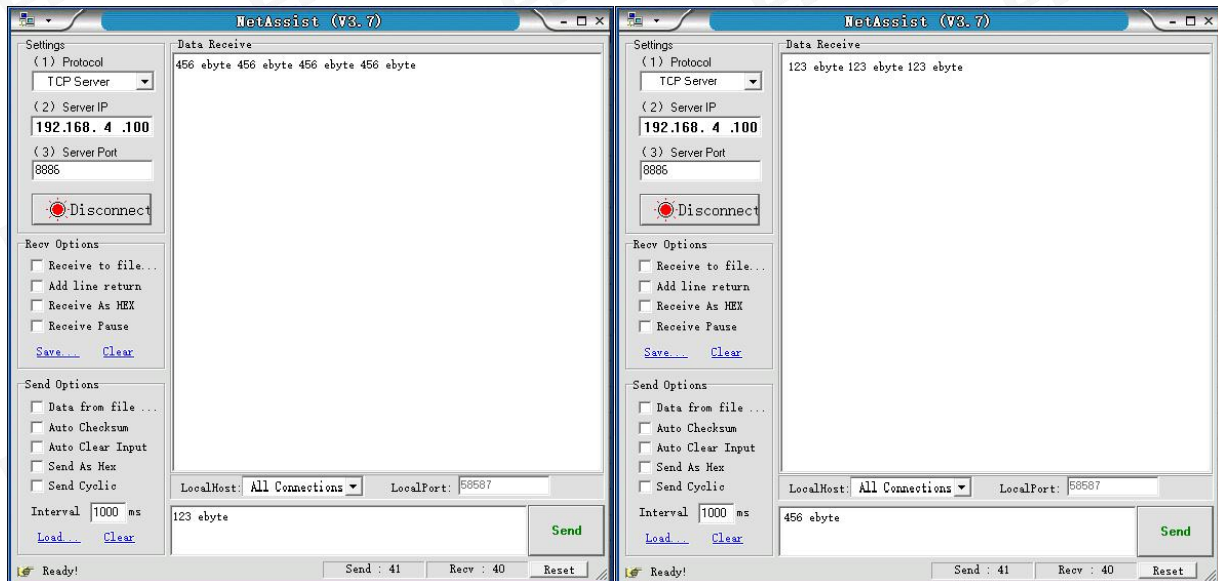

4.4TCP Server guidance

1. Set the" network debugging assistants " on computer A and computer B as TCP Client, the remote host IP is set to 192.168.4.101, and the remote host port number is set to 8886.

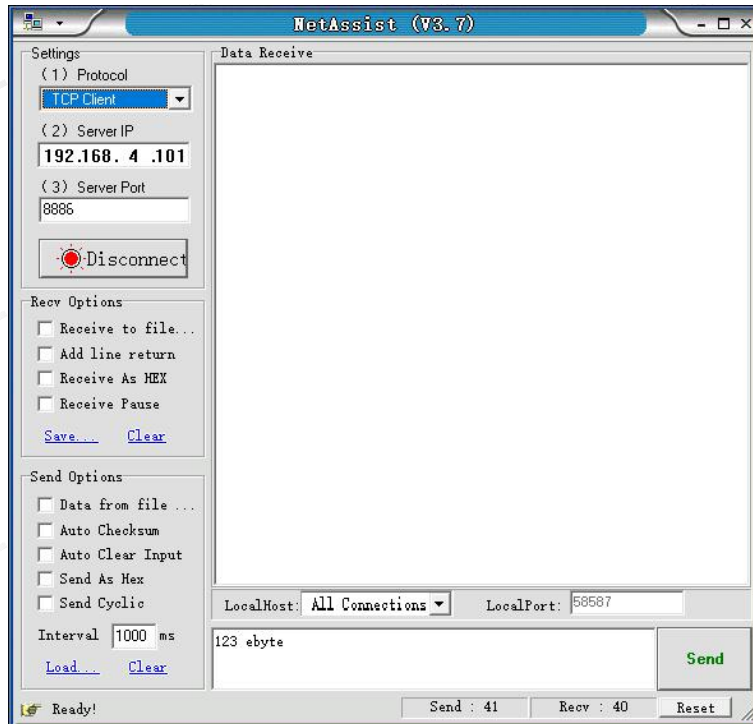

2、 Set the SOCKET A1 network type of Device A and Device B to TCP Server and local port 8886. Click Save to restart the module..

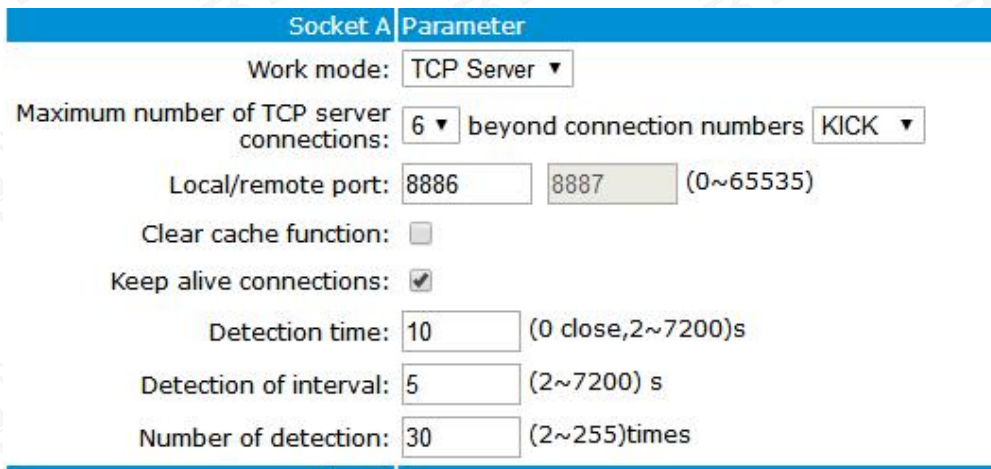

3、 The DTU is connected via Network Debugging Assistant for communication test as shown below.

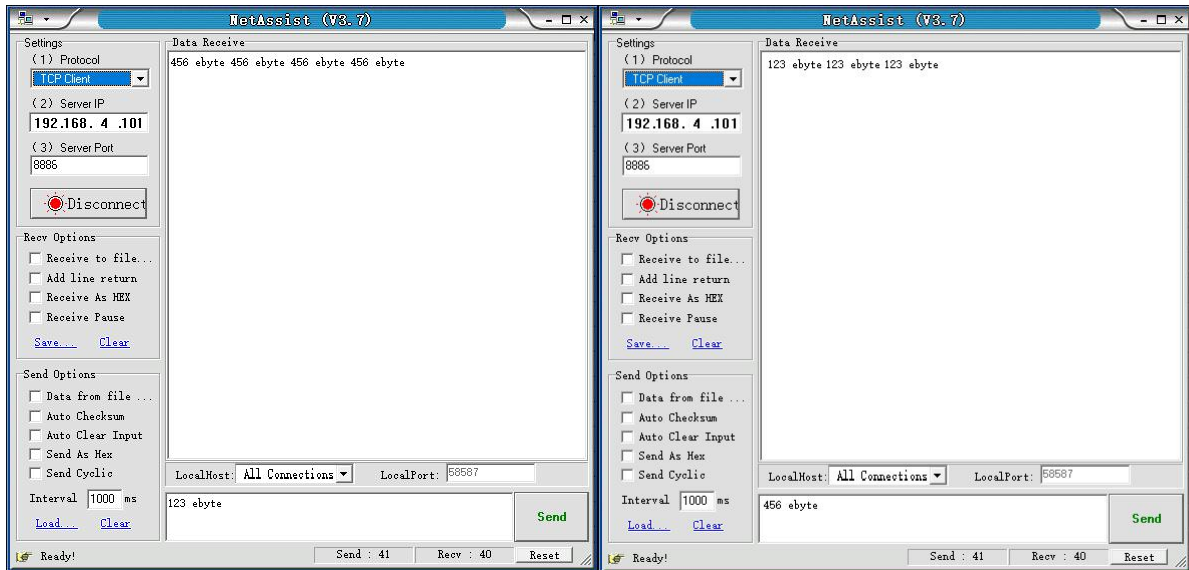

4.5 UDP Client guidance

1、Set “Network Debugging Assistant”as UDP (no need to tell UDP Client and UDP Server), set IP of master as 192.168.4.100, local port number as 8887, remote master as 192.168.4.101:8886.

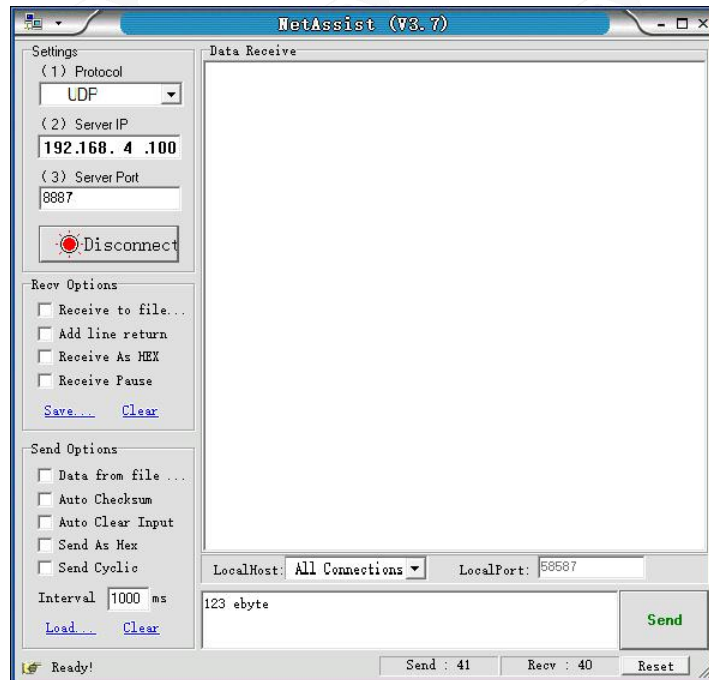

2. Set the SOCKET A1 network type of device A and device B to UDP Client, the target IP address is 192.168.4.100, and the destination port is 8887. Click Save to restart the module.

Socket A Parameter	
Work mode:	UDP Client
Remote server address or domain name:	192.168.4.100
Local/remote port:	8886 8887 (0~65535)
Clear cache function:	<input type="checkbox"/>
Heartbeat packet type:	network heartbeat packet
Heartbeat packet content:	heartbeat msg
HEX:	<input type="checkbox"/>
ASCII:	<input checked="" type="checkbox"/>
Heartbeat packet time:	0 (0 close,2~65535)s
Registered package type:	registration packet closure

3、 The DTU is connected via Network Debugging Assistant for communication test as shown below.

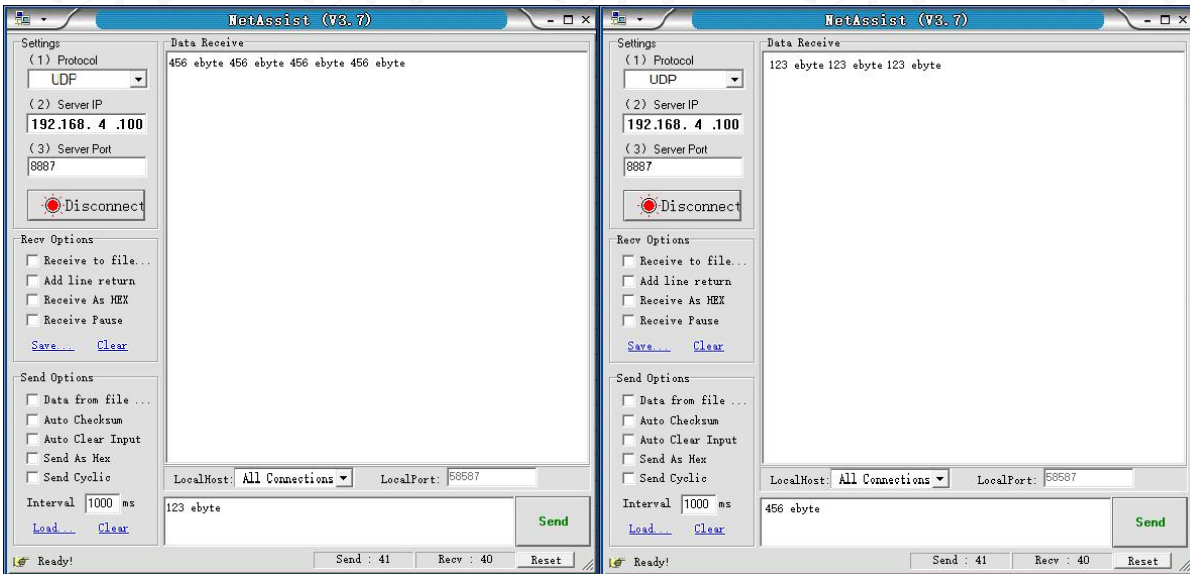

4.6UDP Server guidance

1、 Set “Network Debugging Assistant”: as UDP (no need to tell UDP Client and UDP Server), set local host IP as 192.168.4.101, local port as 8886, remote host as 192.168.4.101:8887.

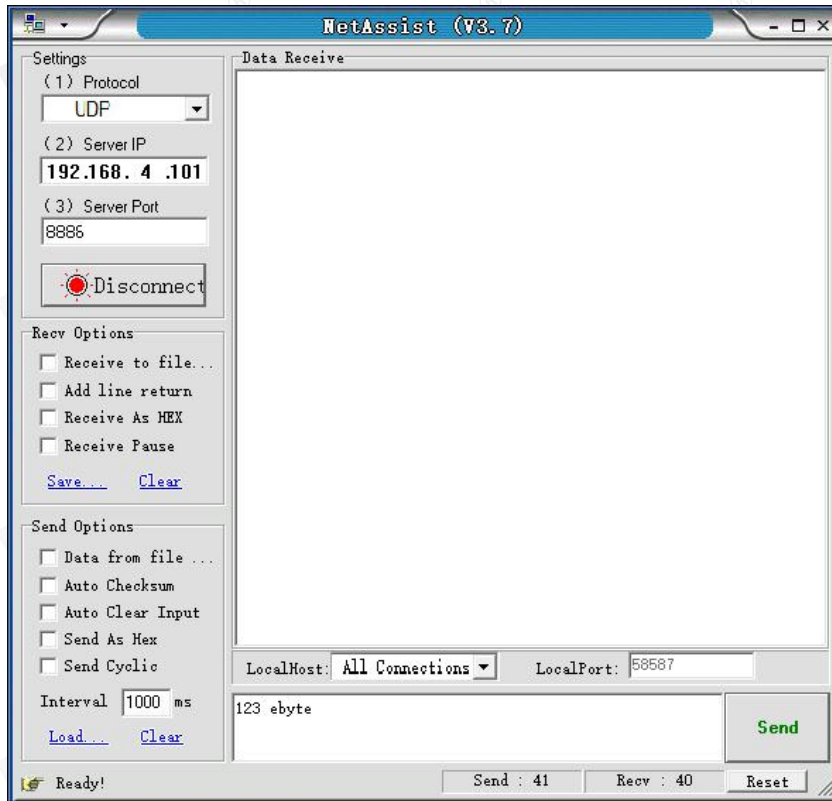

2、 Set the SOCKET A1 network type of device A and device B to UDPS (UDP Server) and local port 8887. Click Save to restart the module.

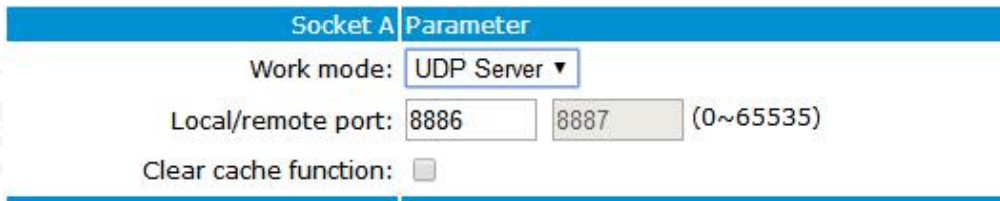

3、 The DTU is connected via Network Debugging Assistant for communication test as shown below.

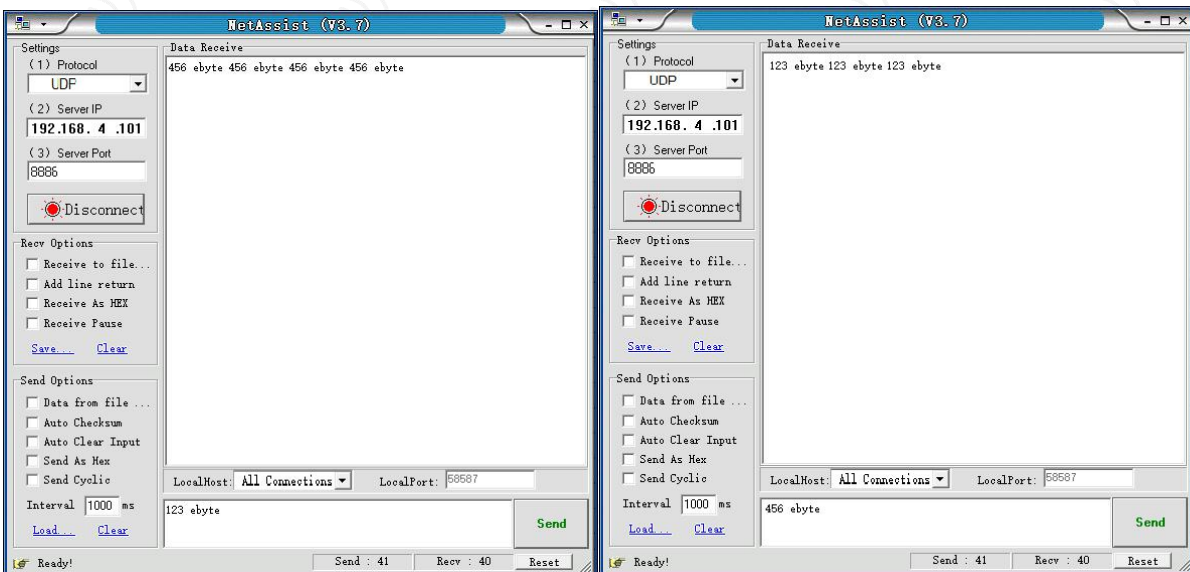

4.7 WEB introduction

The module supports web page configuration. The user can input the module IP address and port (the default port of the browser is 80) through any browser. After the login is successful, the web page is entered, as the picture shows:



Ebyte IOT
-www.ebyte.com-

Ebyte IOT application specialist

Current State	Parameter	Helpful Tips
IP Setting	Type: E90-DTU(900SL30-ETH)	<ul style="list-style-type: none"> SN code: SN code refers to the serial number of the device when the module is registered on Ebyte cloud platform. Connection status: Connection status refers to the real-time identification of whether the current SOCKET A/B is connected in the network.
Parameter Setting	Version: V1.1	
Advanced Setting	Current IP Address: 192.168.4.101	
Management	Mac Address: B2:F7:E2:EF:F4:1B	
	SN Code: 190829161127D8AF	
	Socket A connection: Disconnect	
	Socket B connection: Disconnect	

Copyright ? 2018 Chengdu Ebyte Electronic Technology Co., Ltd. All Right Reserved official website: www.ebyte.com

Select one or more pages for parameter browsing and configuration according to specific needs (take LoRa settings as an example).

LoRa Parameter(E22-900T30S)

WOR role: ▼

WOR cycle: ▼

Module address: range(0~65535)

Network address: range(0~255)

Module channel: range (0~80)

Transmitting power: ▼ dBm

Air data rate: ▼ bps

The length of sub-package: ▼ bytes

Transmission mode: ▼

Communication key: Four-digit hexadecimal system

Relay function:

LBT function:

RSSI byte start:

RSSI ambient noise

After entering parameter, click “Save setting”

Socket B	Parameter
Work mode:	<input type="text" value="TCP Client"/> ▼
Remote server address or domain name:	<input type="text" value="192.168.4.100"/>
Local/remote port:	<input type="text" value="0"/> <input type="text" value="8887"/> (0~65535)
Clear cache function:	<input type="checkbox"/>
Short link break time:	<input type="text" value="0"/> (0 close,2~65535)s
Heartbeat packet type:	<input type="text" value="network heartbeat packet"/> ▼
Heartbeat packet content:	<input type="text" value="heartbeat msg"/>
	HEX: <input type="checkbox"/> ASCII: <input checked="" type="checkbox"/>
Heartbeat packet time:	<input type="text" value="0"/> (0 close,2~65535)s
Registered package type:	<input type="text" value="registration packet closure"/> ▼
Keep alive connections:	<input checked="" type="checkbox"/>
Detection time:	<input type="text" value="10"/> (0 close,2~7200)s
Detection of interval:	<input type="text" value="5"/> (2~7200) s
Number of detection:	<input type="text" value="30"/> (2~255)times

The page will automatically jump to the module management page. After restarting the module, the module will restart and the set parameters will take effect.



Ebyte IOT
-www.ebyte.com-

Ebyte IOT application specialist

Current State	Parameter management	Helpful Tips
IP Setting	Restart module <input type="button" value="Restart module"/>	<ul style="list-style-type: none"> Restart module Restart the module for your configuration to take effect. Factory data reset After the factory settings are restored, the equipment will be restarted automatically.
Parameter Setting	factory data reset <input type="button" value="Factory data reset"/>	
Advanced Setting		
Management		

Revision history

Version	date	Specification	Issued by
1.0	2019-3-5	Initial version	All
1.1	2019-11-29	Version	Blue
1.2	2019-12-25	Version	Blue
1.3	2020-10-20	Version	LY
1.4	2021-01-26	Version	ken

About us

Technical support: support@cdebyte.com

Documents and RF Setting download link: www.cdebyte.com/en/

Tel: +86-28-61399028

Fax: 028-64146160

Web: www.cdebyte.com/en/

Address: B5 Mould Park, 199# Xiqu Ave, High-tech District, Sichuan, China



Chengdu Ebyte Electronic Technology Co.,Ltd.