



DC BRUSHLESS FAN

AF3D9232B 92*92*32mm

Motor:DC Brushless
 Bearing:Two Ball、Sleeve、Hydraulic
 Shell frame: PBT UL94V-0
 Fan blade: PBT UL94V-0
 Insulation:Class B
 Wire:AWG#26UL1007 (optional)
 PIN1:BLACK WIRE---(-)
 PIN2:RED WIRE---(+)



DIMENSIONS DRAWING(unit:mm)

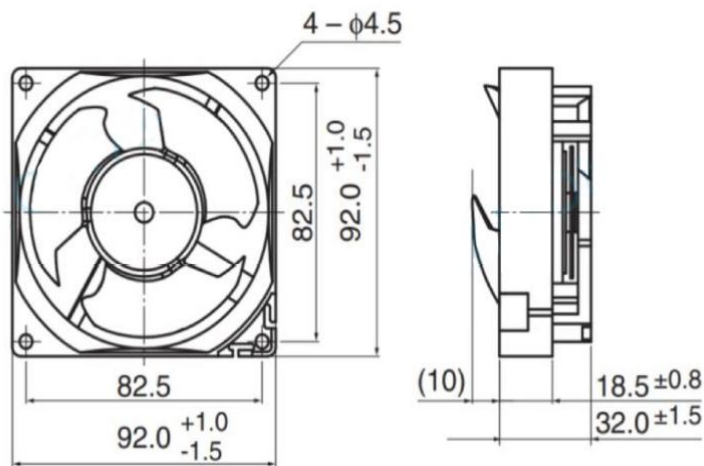

P@Q CURVE(AT RATED VOLTAGE)

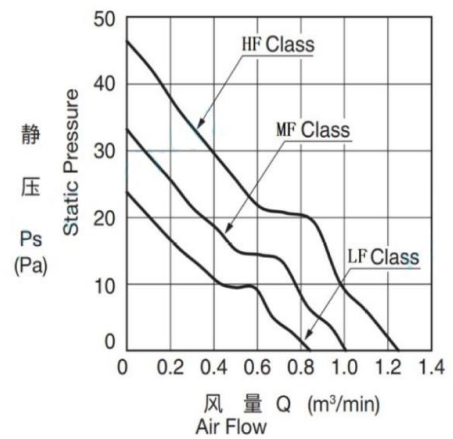

Model	Bearing Mode①	Rated Voltage	Operating voltage range	Rated current	Rated input power	Speed	Maximum air Flow		Maximum Air pressure		Noise
		VDC	VDC	Amp	Watt		R. P. M	M3/min	CFM	mmH2O	
PART. NO.											
AF3D9232B12L	B=Ball S=Sleeve H=Hydraulic	12	6.5~14	0.06	0.72	2400	0.84	29.7	23.6	0.09	25.5
AF3D9232B12M		12	6.5~14	0.08	0.96	2800	1.00	35.3	33.0	0.13	29.5
AF3D9232B12H		12	6.5~14	0.13	1.56	3350	1.24	43.8	46.3	0.19	34.5

①Bearing Mode:Ball/ Sleeve/Hydraulic/Ball (UL)/Sleeve (UL)Hydraulic (UL)

②X=Function: FG RD RDL LD PWM TP VC RC CS RP SS AS CL IPX5

③A=Plug

④C=Customized by customers: Air volume, Air duct, Movement, Service life, Temperature, Noise, Material, Mold. etc.

导引： 编码规则Code Rule

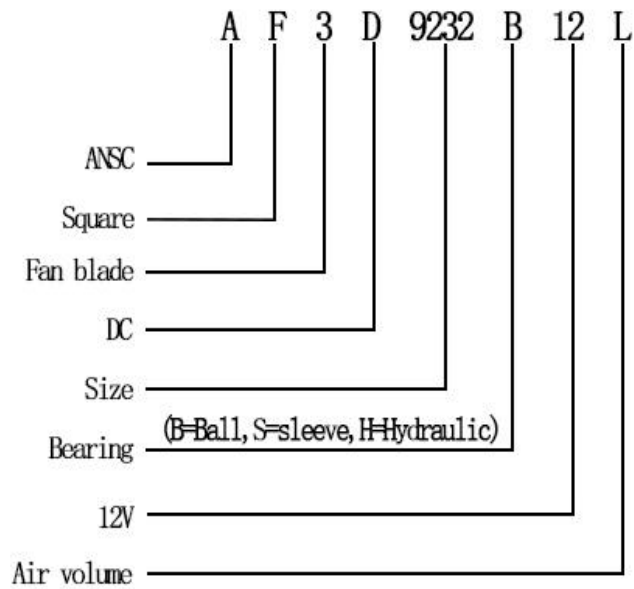

*PROPRIETARY AND CONFIDENTIAL , THE INFORMATION CONTAINED IN THIS DRAWING IS THE SOLE PROPERTY OF <ALL NEW SEMI>.
ANY REPRODUCTION IN PART OR AS A WHOLE WITHOUT THE WRITTEN PERMISSION OF <ALL NEW SEMI> IS PROHIBITED.

<https://allnewsemi.com>
<https://allnewsemi.shop>