

***Rockchip
RK3126C
Datasheet***

**Revision 1.0
May. 2017**

Revision History

Date	Revision	Description
2017-05-09	1.0	Initial Release

Rockchip Confidential

Table of Content

Table of Content	3
Figure Index	5
Table Index.....	6
Warranty Disclaimer.....	7
Chapter 1 Introduction	8
1.1 Features.....	8
1.1.1 Microprocessor.....	8
1.1.2 Memory Organization.....	8
1.1.3 Internal Memory	8
1.1.4 External Memory or Storage device.....	8
1.1.5 System Component	9
1.1.6 Video CODEC.....	11
1.1.7 JPEG CODEC.....	12
1.1.8 Image Enhancement (IEP module).....	12
1.1.9 Graphics Engine	12
1.1.10 Video IN/OUT.....	13
1.1.11 MIPI Interface.....	14
1.1.12 LVDS	14
1.1.13 Audio Interface.....	14
1.1.14 Connectivity.....	15
1.1.15 Others	16
1.2 Block Diagram	17
Chapter 2 Package information	18
2.1 Ordering information	18
2.2 Top Marking.....	18
2.3 LQFP176 Dimension.....	18
2.3.1 Pin Map.....	20
2.4 Pin Description.....	22
2.4.1 RK3126C power/ground IO descriptions.....	22
2.4.2 RK3126C function IO descriptions.....	23
2.4.3 IO pin name descriptions.....	29
2.4.4 RK3126C IO Type.....	32
Chapter 3 Electrical Specification	34
3.1 Absolute Maximum Ratings.....	34
3.2 Recommended Operating Conditions.....	34
3.3 DC Characteristics	35
3.4 Recommended Operating Frequency	36
3.5 Electrical Characteristics for General IO.....	39
3.6 Electrical Characteristics for PLL	39
3.7 Electrical Characteristics for SAR-ADC	40
3.8 Electrical Characteristics for USB OTG/Host2.0 Interface	41
3.9 Electrical Characteristics for DDR IO	41
3.10 Electrical Characteristics for LVDS.....	42
3.11 Electrical Characteristics for eFuse	42
3.12 Hardware Guideline	43

3.12.1 Reference design for RK3126C oscillator PCB connection 43
3.12.2 Reference design for PLL PCB connection 43
3.12.3 Reference design for USB OTG/Host2.0 connection 44
3.12.4 Reference design for Audio Codec connection..... 45
3.12.5 RK3126C Power on reset descriptions 45
Chapter 4 Thermal Management 47
 4.1 Overview.....47
 4.2 Package Thermal Characteristics47

Rockchip Confidential

Figure Index

Fig.1-1 RK3126C Block Diagram17
 Fig.2-1 RK3126C LQFP176 Package Top View.....19
 Fig.2-2 RK3126C LQFP176 Package Side View19
 Fig.2-3 RK3126C LQFP176 Package Dimension19
 Fig.2-4 RK3126C LQFP176 Pin Map21
 Fig.3-1 External Reference Circuit for 24MHzOscillators.....43
 Fig.3-2 RK3126C USB OTG/Host2.0 differential lines requirement.....44
 Fig.3-3 RK3126C USB OTG/Host2.0 ground plane guide.....44
 Fig.3-4 RK3126C USB OTG/Host2.0 component placement.....45
 Fig.3-5 RK3126C Audio Codec interface reference connection45
 Fig.3-6 RK3126C reset signals sequence46

Rockchip Confidential

Table Index

Table 2-1 RK3126C Power/Ground IO information22

Table 2-2 RK3126C IO descriptions23

Table 2-3 RK3126C IO function description list.....29

Table 2-4 RK3126C IO Type List.....32

Table 3-1 RK3126C absolute maximum ratings34

Table 3-2 RK3126C recommended operating conditions.....34

Table 3-3 RK3126C DC Characteristics35

Table 3-4 Recommended operating frequency for PLL and oscillator domain36

Table 3-5 Recommended operating frequency for CPU core.....37

Table 3-6 Recommended operating frequency for PD_CPU domain37

Table 3-7 Recommended operating frequency for PD_PERI domain37

Table 3-8 Recommended operating frequency for PD_VIO domain38

Table 3-9 Recommended operating frequency PD_GPU domain.....39

Table 3-10 Recommended operating frequency for PD_VIDEO domain39

Table 3-11 RK3126C Electrical Characteristics for Digital General IO.....39

Table 3-12 RK3126C Electrical Characteristics for PLL.....39

Table 3-13 RK3126C Electrical Characteristics for SAR-ADC.....40

Table 3-14 RK3126C Electrical Characteristics for USB OTG/Host2.0 Interface41

Table 3-15 RK3126C Electrical Characteristics for DDR IO41

Table 3-16 RK3126C Electrical Characteristics for eFuse42

Table 4-1 RK3126C Thermal Resistance Characteristics47

Warranty Disclaimer

Rockchip Electronics Co., Ltd makes no warranty, representation or guarantee (expressed, implied, statutory, or otherwise) by or with respect to anything in this document, and shall not be liable for any implied warranties of non-infringement, merchantability or fitness for a particular purpose or for any indirect, special or consequential damages.

Information furnished is believed to be accurate and reliable. However, Rockchip Electronics Co., Ltd assumes no responsibility for the consequences of use of such information or for any infringement of patents or other rights of third parties that may result from its use.

Rockchip Electronics Co., Ltd's products are not designed, intended, or authorized for using as components in systems intended for surgical implant into the body, or other applications intended to support or sustain life, or for any other application in which the failure of the Rockchip Electronics Co., Ltd's product could create a situation where personal injury or death may occur, should buyer purchase or use Rockchip Electronics Co.,Ltd's products for any such unintended or unauthorized application, buyers shall indemnify and hold Rockchip Electronics Co.,Ltd and its officers, employees, subsidiaries, affiliates, and distributors harmless against all claims, costs, damages, expenses, and reasonable attorney fees arising out of, either directly or indirectly, any claim of personal injury or death that may be associated with such unintended or unauthorized use, even if such claim alleges that Rockchip Electronics Co.,Ltd was negligent regarding the design or manufacture of the part.

Copyright and Patent Right

Information in this document is provided solely to enable system and software implementers to use Rockchip Electronics Co., Ltd's products. There are no expressed or implied copyright licenses granted hereunder to design or fabricate any integrated circuits or integrated circuits based on the information in this document.

Rockchip Electronics Co., Ltd does not convey any license under its patent rights nor the rights of others.

All copyright and patent rights referenced in this document belong to their respective owners and shall be subject to corresponding copyright and patent licensing requirements.

Trademarks

Rockchip and Rockchip™ logo and the name of Rockchip Electronics Co.,Ltd's products are trademarks of Rockchip Electronics Co.,Ltd. and are exclusively owned by Rockchip Electronics Co.,Ltd. References to other companies and their products use trademarks owned by the respective companies and are for reference purpose only.

Confidentiality

The information contained herein (including any attachments) is confidential. The recipient hereby acknowledges the confidentiality of this document, and except for the specific purpose, this document shall not be disclosed to any third party.

Reverse engineering or disassembly is prohibited.

ROCKCHIP ELECTRONICS CO.,LTD. RESERVES THE RIGHT TO MAKE CHANGES IN ITS PRODUCTS OR PRODUCT SPECIFICATIONS WITH THE INTENT TO IMPROVE FUNCTION OR DESIGN AT ANY TIME AND WITHOUT NOTICE AND IS NOT REQUIRED TO UNDATE THIS DOCUMENTATION TO REFLECT SUCH CHANGES.

Copyright © 2017 Rockchip Electronics Co., Ltd.

All rights reserved. No part of this publication may be reproduced, stored in a retrieval system, or transmitted in any form or by any means, electric or mechanical, by photocopying, recording, or otherwise, without the prior written consent of Rockchip Electronics Co., Ltd.

Chapter 1 Introduction

RK3126C is a high performance Quad-core application processor for tablet. It is a high-integration and cost efficient SOC.

Quad-core Cortex-A7 is integrated with separately Neon and FPU, and shared 256KB L2 Cache. Mali400 MP2 GPU is embedded to support smoothly high-resolution display and mainstream game. Lots of high-performance interface to get very flexible solution, 16bits DDR3 provides high memory bandwidths for high-performance.

1.1 Features

The features listed below which may or may not be present in actual product, may be subject to the third party licensing requirements. Please contact with Rockchip for actual product feature configurations and licensing requirements.

1.1.1 Microprocessor

- Quad-core ARM Cortex-A7MPCore processor, a high-performance, low-power and cached application processor
- Full implementation of the ARM architecture v7-A instruction set, ARM Neon Advanced SIMD (single instruction, multiple data) support for accelerated media and signal processing computation
- Separately Integrated Neon and FPU per CPU
- 32KB/32KB L1 ICache/DCache per CPU
- Unified 256KB L2 Cache

1.1.2 Memory Organization

- Internal on-chip memory
 - BootRom
 - Internal SRAM
- External off-chip memory
 - DDR3/ DDR3L
 - Async/Toggle/Sync Nand Flash(include LBA Nand)

1.1.3 Internal Memory

- Internal BootRom
 - Size : 16KB
 - Support system boot from the following device :
 - ◆ 8bits Async Nand Flash
 - ◆ 8bits toggle Nand Flash
 - ◆ SPI interface
 - ◆ eMMC interface
 - ◆ SDMMC interface
 - Support system code download by the following interface:
 - ◆ USB OTG interface
- Internal SRAM
 - Size : 8KB
 - Support security and non-security access
 - Security or non-security space is software programmable

1.1.4 External Memory or Storage device

- Dynamic Memory Interface (DDR3/DDR3L)
 - Compatible with JEDEC standard DDR3/DDR3L SDRAM
 - Supports DDR3-800/DDR3L-800
 - Supports 16Bits data width totally 2GB (max) address space.
 - 7 host ports with 64bits/128bits AXI bus interface for system access, AXI bus clock is asynchronous with DDR clock
 - Programmable timing parameters to support DDR3/DDR3L SDRAM from various

- vendor
 - Advanced command reordering and scheduling to maximize bus utilization
 - Low power modes, such as power-down and self-refresh for DDR3/DDR3L SDRAM; Compensation for board delays and variable latencies through programmable pipelines
 - Programmable output and ODT impedance with dynamic PVT compensation
- Nand Flash Interface
 - Support 8bits async/toggle/sync nandflash, up to 4 banks
 - Support LBA nandflash
 - 16bits, 24bits, 40bits, 60bits hardware ECC
 - For DDR nandflash, support DLL bypass and 1/4 or 1/8 clock adjust, maximum clock rate is 66.5MHz
 - For async/toggle nandflash, support configurable interface timing , maximum data rate is 16bit/cycle
 - Embedded AHB master interface to do data transfer by DMA method
 - Also support data transfer by AHB slave interface together with external DMAC
- eMMC Interface
 - Compatible with standard iNAND interface
 - Support MMC4.41 protocol
 - Provide eMMC boot sequence to receive boot data from external eMMC device
 - Support FIFO over-run and under-run prevention by stopping card clock automatically
 - Support CRC generation and error detection
 - Embedded clock frequency division control to provide programmable baud rate
 - Support block size from 1 to 65535Bytes
 - 8bits data bus width
- SD/MMC Interface
 - Compatible with SD2.0, MMC ver4.41
 - Support FIFO over-run and under-run prevention by stopping card clock automatically
 - Support CRC generation and error detection
 - Embedded clock frequency division control to provide programmable baud rate
 - Support block size from 1 to 65535Bytes
 - Data bus width is 4bits

1.1.5 System Component

- CRU (clock & reset unit)
 - Support clock gating control for individual components inside RK3126C
 - One oscillator with 24MHz clock input and 4 embedded PLLs
 - Support global soft-reset control for whole SOC, also individual soft-reset for every components
- PMU(power management unit)
 - Multiple configurable work modes to save power by different frequency or automatically clock gating control or power domain on/off control
 - Lots of wakeup sources in different mode
 - 2 separate voltage domains
 - 3 separate power domains, which can be power up/down by software based on different application scenes
- Timer
 - 6 general Timers and 2 secure timers in SoC with interrupt-based operation
 - Provide two operation modes: free-running and user-defined count
 - Support timer work state checkable

- Fixed 24MHz clock input
- PWM
 - Four on-chip PWMs with interrupt-based operation
 - Programmable pre-scaled operation to bus clock and then further scaled
 - Embedded 32-bit timer/counter facility
 - Support capture mode
 - Support continuous mode or one-shot mode
 - Provides reference mode and output various duty-cycle waveform
- WatchDog
 - 32 bits watchdog counter width
 - Counter clock is from APB bus clock
 - Counter counts down from a preset value to 0 to indicate the occurrence of a timeout
 - WDT can perform two types of operations when timeout occurs:
 - ◆ Generate a system reset
 - ◆ First generate an interrupt and if this is not cleared by the service routine by the time a second timeout occurs then generate a system reset
 - Programmable reset pulse length
 - Totally 16 defined-ranges of main timeout period
- Bus Architecture
 - 128bit/64-bit/32-bit multi-layer AXI/AHB/APB composite bus architecture
 - 5 embedded AXI interconnect
 - ◆ CPU interconnect with four 64-bits AXI masters, one 64-bits AXI slaves, one 32-bits AHB master and lots of 32-bits AHB/APB slaves
 - ◆ PERI interconnect with two 64-bits AXI masters, one 64-bits AXI slave, five 32-bits AHB masters and lots of 32-bits AHB/APB slaves
 - ◆ Display interconnect with three 128-bits AXI master, four 64-bits AXI masters and one 32-bits AHB slave
 - ◆ GPU interconnect with one 128-bits AXI master with point-to-point AXI-lite architecture and 32-bits APB slave
 - ◆ VCODEC interconnect also with two 64-bits AXI master and two 32-bits AHB slave, they are point-to-point AXI-lite architecture
 - Flexible different QoS solution to improve the utility of bus bandwidth
- Interrupt Controller
 - Support 3 PPI interrupt source and 74 SPI interrupt sources input from different components inside RK3126C
 - Support 16 software-triggered interrupts
 - Input interrupt level is fixed , only high-level sensitive
 - Two interrupt outputs (nFIQ and nIRQ) separately for each Cortex-A7, both are low-level sensitive
 - Support different interrupt priority for each interrupt source, and they are always software-programmable
- DMAC
 - Micro-code programming based DMA
 - The specific instruction set provides flexibility for programming DMA transfers
 - Linked list DMA function is supported to complete scatter-gather transfer
 - Support internal instruction cache
 - Embedded DMA manager thread
 - Support data transfer types with memory-to-memory, memory-to-peripheral, peripheral-to-memory
 - Signals the occurrence of various DMA events using the interrupt output signals
 - Mapping relationship between each channel and different interrupt outputs is

- software-programmable
 - One embedded DMA controller PERI_DMAL for peripheral system
 - PERI_DMAL features:
 - ◆ 8 channels totally
 - ◆ 16 hardware request from peripherals
 - ◆ 2 interrupt output
- Security system
 - Support trustzone technology for the following components
 - ◆ Cortex-A7, support security and non-security mode, switch by software
 - ◆ 512bit eFuse, only accessed by Cortex-A7 in security mode
 - ◆ Internal memory , part of space is addressed only in security mode, detailed size is software-programmable together with TZMA(trustzone memory adapter) and TZPC(trustzone protection controller)

1.1.6 Video CODEC

- Shared internal memory and bus interface for video decoder and encoder
- Embedded memory management unit(MMU)
- Video Decoder
 - Real-time video decoder of MPEG-1, MPEG-2, MPEG-4,H.263, H.264,VC-1, VP8, MVC
 - MMU Embedded
 - Supports frame timeout interrupt , frame finish interrupt and bit stream error interrupt
 - Error detection and concealment support for all video formats
 - Output data format is YUV420 semi-planar, and YUV400(monochrome) is also supported for H.264
 - H.264 up to HP level 4.2 : 1080p@30fps
 - MPEG-4 up to ASP level 5 : 1080p@30fps
 - MPEG-2 up to MP : 1080p@30fps
 - MPEG-1 up to MP : 1080p@30fps
 - H.263 : 576p@60fps
 - VC-1 up to AP level 3 : 1080p@30fps
 - VP8 : 1080p@30fps
 - MVC : 1080p@30fps
 - For H.264, image cropping not supported
 - For MPEG-4,GMC(global motion compensation)not supported
 - For VC-1, up-scaling and range mapping are supported in image post-processor
 - For MPEG-4 SP/H.263/Sorenson spark, using a modified H.264 in-loop filter to implement deblocking filter in post-processor unit
- Video Encoder
 - Support video encoder for H.264 UP to HP@level4.1, MVC and VP8
 - Only support I and P slices, not B slices
 - Support error resilience based on constrained intra prediction and slices
 - Input data format:
 - ◆ YCbCr 4:2:0 planar
 - ◆ YCbCr 4:2:0 semi-planar
 - ◆ YCbYCr 4:2:2
 - ◆ CbYCrY 4:2:2 interleaved
 - ◆ RGB444 and BGR444
 - ◆ RGB555 and BGR555
 - ◆ RGB565 and BGR565
 - ◆ RGB888 and BRG888
 - ◆ RGB101010 and BRG101010
 - Image size is from 96x96 to 1920x1088(Full HD)
 - Maximum frame rate is up to 30fps@1280*720

- Bit rate supported is from 10Kbps to 20Mbps

1.1.7 JPEG CODEC

- JPEG decoder
 - Input JPEG file : YCbCr 4:0:0, 4:2:0, 4:2:2, 4:4:0, 4:1:1 and 4:4:4 sampling formats
 - Output raw image : YCbCr 4:0:0, 4:2:0, 4:2:2, 4:4:0, 4:1:1 and 4:4:4 semi-planar
 - Decoder size is from 48x48 to 8176x8176(66.8Mpixels)
 - Support JPEG ROI(region of image) decode
 - Maximum data rate is up to 76million pixels per second
 - Embedded memory management unit(MMU)
- JPEG encoder
 - Input raw image :
 - ◆ YCbCr 4:2:0 planar
 - ◆ YCbCr 4:2:0 semi-planar
 - ◆ YCbYCr 4:2:2
 - ◆ CbYCrY 4:2:2 interleaved
 - ◆ RGB444 and BGR444
 - ◆ RGB555 and BGR555
 - ◆ RGB565 and BGR565
 - ◆ RGB888 and BRG888
 - ◆ RGB101010 and BRG101010
 - Output JPEG file : JFIF file format 1.02 or Non-progressive JPEG
 - Encoder image size up to 8192x8192(64million pixels) from 96x32
 - Maximum data rate up to 90million pixels per second
 - Embedded memory management unit(MMU)

1.1.8 Image Enhancement (IEP module)

- Image format support
 - Input data: YUV420/YUV422
 - Output data: YUV420/YUV422
 - YUV swap
 - UV SP/P
 - YUV up/down sampling
 - Max source image resolution: 1920x1080
- YUV enhancement
 - Hue, Saturation, Brightness, Contrast adjustment
- De-interlace
 - Source width up to 1920
 - Configured high frequency de-interlace
 - I2O1B/I2O1T mode
- Interface
 - 32bit AHB bus slave
 - 64bit AXI bus master
 - Combined interrupt output

1.1.9 Graphics Engine

- 3D Graphics Engine :
 - High performance OpenGL ES1.1 and 2.0, OpenVG1.1 etc.
 - Embedded 4shader cores with shared hierarchical tiler
 - Separate vertex(geometry) and fragment(pixel) processing for maximum parallel throughput
 - Provide MMU and L2 Cache with 32KB size
 - Triangle rate : 30M triangles/s
 - Pixel rate: 300 pixels/s @ 150MHz
- 2D Graphics Engine(RGA module) :

- Pixel rate: 300M pixel/s without scale, 150M pixel/s with bilinear scale, 66.5M pixel/s with bicubic scale.
- Bit Blit with Strength Blit, Simple Blit and Filter Blit
- Color fill with gradient fill, and pattern fill
- Line drawing with anti-aliasing and specified width
- High-performance stretch and shrink
- Monochrome expansion for text rendering
- ROP2, ROP3, ROP4 full alpha blending and transparency
- Alpha blending modes including Java 2 Porter-Duff compositing blending rules , chroma key, and pattern mask
- 8K x 8K raster 2D coordinate system
- Arbitrary degrees rotation with anti-aliasing on every 2D primitive
- Programmable bicubic filter to support image scaling
- Blending, scaling and rotation are supported in one pass for stretch blit
- Source formats :
 - ◆ ABGR8888, XBGR888, ARGB8888, XRGB888
 - ◆ RGB888, RGB565
 - ◆ RGBA5551, RGBA4444
 - ◆ YUV420 planar, YUV420 semi-planar
 - ◆ YUV422 planar, YUV422 semi-planar
 - ◆ BPP8, BPP4, BPP2, BPP1
- Destination formats :
 - ◆ ABGR8888, XBGR888, ARGB8888, XRGB888
 - ◆ RGB888, RGB565
 - ◆ RGBA5551, RGBA4444
 - ◆ YUV420 planar, YUV420 semi-planar only in filter and pre-scale mode
 - ◆ YUV422 planar, YUV422 semi-planar only in filter and pre-scale mode

1.1.10 Video IN/OUT

- Camera Interface
 - Support up to 5M pixels
 - 8bits CCIR656(PAL/NTSC) interface
 - 8bits parallel interface
 - YUV422 data input format with adjustable YUV sequence
 - YUV422, YUV420 output format with separately Y and UV space
 - Support picture in picture (PIP)
 - Support image crop with arbitrary windows
- Display Interface
 - Support LCD or TFT interfaces up to 1920x1080
 - Parallel RGB LCD Interface :
 - RGB888 (24bits), RGB666 (18bits) , RGB565 (15bits)
 - Serial RGB LCD Interface: 2x12-bit, 3x8-bit(RGB delta support), 3x8-bit + dummy
 - MCU LCD interface: i-8080(up to 24-bit RGB), Hold/Auto/Bypass modes
 - 4 display layers :
 - ◆ One background layer with programmable 24bits color
 - ◆ One video layer (win0)
 - RGB888, ARGB888, RGB565, YCbCr422, YCbCr420, YCbCr444
 - maximum resolution is 1920x1080, support virtual display
 - 1/8 to 8 scaling up/down engine with arbitrary non-integer ratio
 - 256 level alpha blending(pre-multiplied alpha support)
 - Support transparency color key
 - De-flicker support for interlace output
 - Direct path support
 - YCbCr2RGB(rec601-mpeg/rec601-jpeg/rec709)
 - RGB2YCbCr(BT601/BT709)
 - ◆ One video layer (win1)
 - RGB888, ARGB888, RGB565

- Support virtual display
- 256 level alpha blending (pre-multiplied alpha support)
- Support transparency color key
- Direct path support
- RGB2YCbCr(BT601/BT709)
- ◆ Hardware cursor(win3)
 - 8BPP (ARGB888 LUT)
 - Support two size: 32x32 and 64x64
 - 256 level alpha blending
 - Support HWC over panel at right and below side
- Win0 and Win1 layer overlay exchangeable
- 3 x 256 x 8 bits display LUTs
- Support replication(16bits to 24bits) and dithering(24bits to 16bits/ 18bits) operation
- Blank and blank display
- Scaler
 - ◆ Output for LVDS/RGB (max up to 1024x768)

1.1.11 MIPI Interface

- Embedded 1 MIPI DPHY for TX
- Support 4 data lane
- Support 1080p @ 60fps output

1.1.12 LVDS

- 135MHz clock support
- 28:4 data sub channel compression at data rates up to 945 Mbps per channel
- Support VGA,SVGA,XGA and single pixel SXGA
- PLL requires no external components
- Comply with the Standard TIA/EIA-644-A LVDS standard
- Support alternative LVDS output or LVTTTL output

1.1.13 Audio Interface

- I2S/PCM with 2ch
 - Up to 2 channels (2xTX, 2xRX)
 - Audio resolution from 16bits to 32bits
 - Sample rate up to 192KHz
 - Provides master and slave work mode, software configurable
 - Support 3 I2S formats (normal , left-justified , right-justified)
 - Support 4 PCM formats(early , late1 , late2 , late3)
 - I2S and PCM cannot be used at the same time
- Audio Codec
 - 18 to 24 bit High Order Sigma-Delta modulation for DAC for >93 dB SNR configurable
 - 16 to 18 bit High Order Sigma-Delta modulation for ADC for >90 dB SNR configurable
 - Digital interpolation and decimation filter integrated
 - Line-in, Microphone in and Speaker out Interface
 - On-Chip Analog Post Filter and digital filters
 - Single-ended or differential Input and Output
 - Sampling Rate of 8kHz/12kHz/16kHz/ 24kHz/32kHz /48kHz/44.1K/96KHz
 - Support 16ohm to 32ohm Head Phone and Speaker Phone Output
 - Mono, Stereo channel supported
 - Optional Fractional PLL available that support 6Mhz to 20Mhz clock input to any clock output that meets 8kHz/12kHz/16kHz/ 24kHz/32kHz /48kHz/44.1K/96KHz and 128 time oversampling ratio.

1.1.14 Connectivity

- SDIO interface
 - Compatible with SDIO 3.0 protocol
 - 4bits data bus widths
- SPI Controller
 - 1 on-chip SPI controller
 - Support serial-master and serial-slave mode, software-configurable
 - DMA-based or interrupt-based operation
 - Embedded two 32x16bits FIFO for TX and RX operation respectively
 - Support 2 chip-selects output in serial-master mode
- UART Controller
 - 2 on-chip uart controller inside RK3126C
 - DMA-based or interrupt-based operation
 - UART1/UART2 Embedded two 32Bytes FIFO for TX and RX operation respectively
 - Support 5bit,6bit,7bit,8bit serial data transmit or receive
 - Standard asynchronous communication bits such as start,stop and parity
 - Support different input clock for uart operation to get up to 4Mbps or other special baud rate
 - Support non-integer clock divides for baud clock generation
 - Support auto flow control mode
- I2C controller
 - 3 on-chip I2C controller in RK3126C
 - Multi-master I2C operation
 - Support 7bits and 10bits address mode
 - Software programmable clock frequency and transfer rate up to 400Kbit/s in the fast mode
 - Serial 8bits oriented and bidirectional data transfers can be made at up to 100Kbit/s in the standard mode
- GPIO
 - 4 groups of GPIO (GPIO0~GPIO3) , 32 GPIOs per group in GPIO0~GPIO3, totally have 128 GPIOs
 - All of GPIOs can be used to generate interrupt to Cortex-A7
 - All of pull-up GPIOs are software-programmable for pull-up resistor or not
 - All of pull-down GPIOs are software-programmable for pull-down resistor or not
 - All of GPIOs are always in input direction in default after power-on-reset
- USB Host2.0
 - Embedded 1 USB Host2.0 interfaces
 - Compatible with USB Host2.0 specification
 - Supports high-speed(480Mbps), full-speed(12Mbps) and low-speed(1.5Mbps) mode
 - Provides 16 host mode channels
 - Support periodic out channel in host mode
- USB OTG2.0
 - Compatible with USB OTG2.0 specification
 - Supports high-speed(480Mbps), full-speed(12Mbps) and low-speed(1.5Mbps) mode
 - Support up to 9 device mode endpoints in addition to control endpoint 0
 - Support up to 6 device mode IN endpoints including control endpoint 0
 - Endpoints 1/3/5/7 can be used only as data IN endpoint
 - Endpoints 2/4/6 can be used only as data OUT endpoint
 - Endpoints 8/9 can be used as data OUT and IN endpoint
 - Provides 9 host mode channels

1.1.15 Others

- SAR-ADC(Successive Approximation Register)
 - 3-channel single-ended 10-bit SAR analog-to-digital converter
 - Sample rate F_s is 200KHz
 - SAR-ADC clock must be large than $11 \cdot F_s$, recommend is $11 \cdot F_s$
 - DNL is less than ± 1 LSB , INL is less than ± 2.0 LSB
 - Power supply is 3.3V ($\pm 10\%$) for analog interface, power dissipation is less than 900uW

- eFuse
 - Two 512bit high-density electrical Fuse is integrated, and one of them is secure access only
 - Support standby mode
 - Programming condition : VP must be 2.5V($\pm 10\%$)
 - Provide inactive mode, VP must be 0V or Floating in this mode.

1.2 Block Diagram

The following diagram shows the basic block diagram.

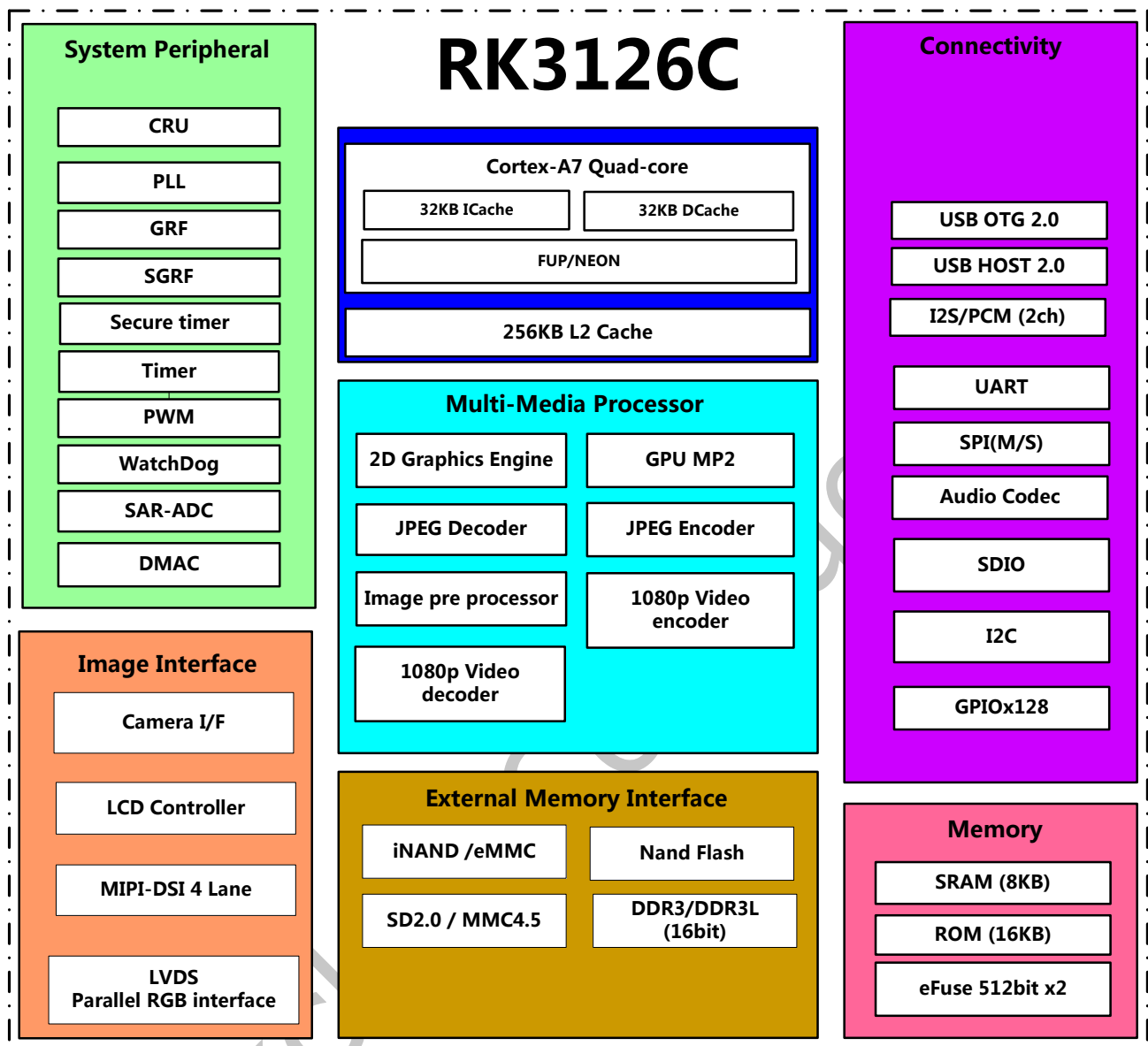

Fig. 1-1 RK3126C Block Diagram

Chapter 2 Package information

2.1 Ordering information

Orderable Device	RoHS status	Package	Package Qty	Device special feature
RK3126C	RoHS	LQFP176	600	Quad core A7 AP

2.2 Top Marking

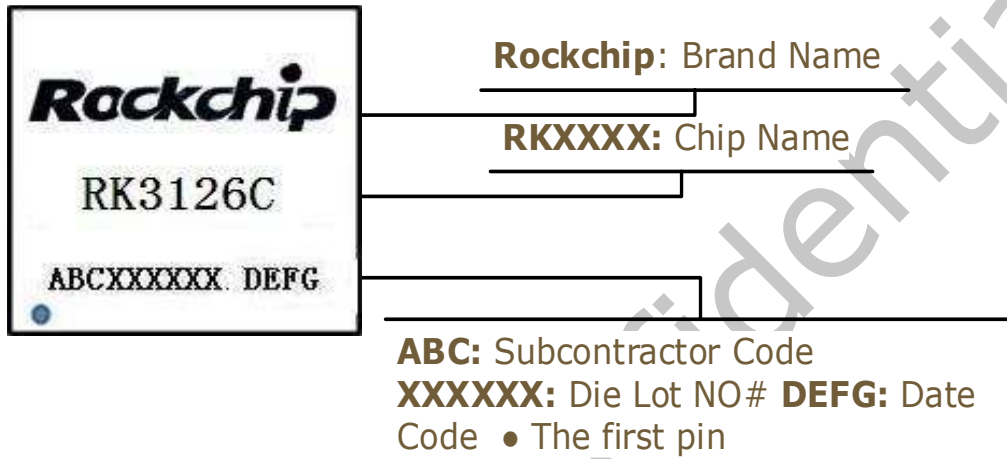

2.3 LQFP176 Dimension

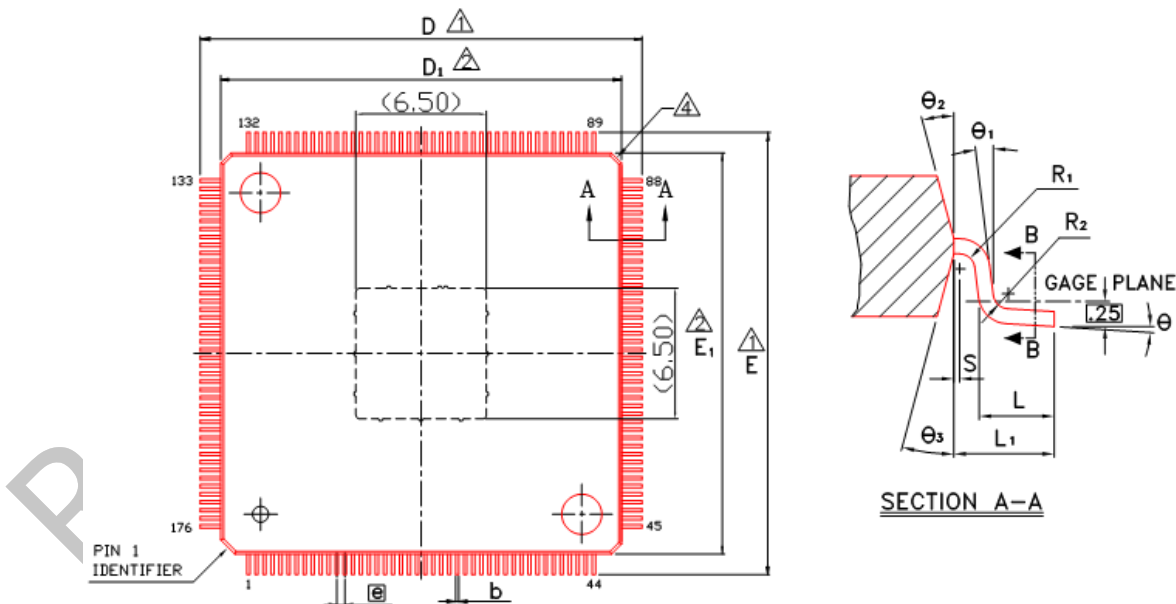

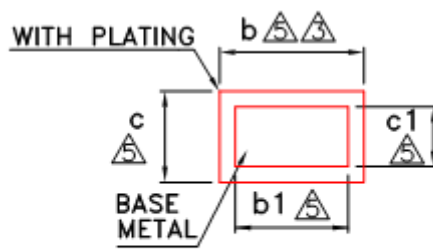

SECTION B-B

Fig.2-1 RK3126C LQFP176 Package Top View



Fig.2-2 RK3126C LQFP176 Package Side View

Symbol	Dimension in mm			Dimension in inch		
	Min	Nom	Max	Min	Nom	Max
A	—	—	1.60	—	—	0.063
A ₁	0.05	—	0.15	0.002	—	0.006
A ₂	1.35	1.40	1.45	0.053	0.055	0.057
b	0.13	0.18	0.23	0.005	0.007	0.009
b ₁	0.13	0.16	0.19	0.005	0.006	0.007
c	0.09	—	0.20	0.004	—	0.008
c ₁	0.09	0.12	0.16	0.004	0.005	0.006
D	21.60	22.00	22.40	0.850	0.866	0.882
D ₁	—	20.00	—	—	0.787	—
E	21.60	22.00	22.40	0.850	0.866	0.882
E ₁	—	20.00	—	—	0.787	—
e	0.40 BSC			0.016 BSC		
L	0.45	0.60	0.75	0.018	0.024	0.030
L ₁	1.00 REF			0.039 REF		
R ₁	0.08	—	—	0.003	—	—
R ₂	0.08	—	—	0.003	—	—
S	0.20	—	—	0.008	—	—
θ	0°	3.5°	7°	0°	3.5°	7°
θ ₁	0°	—	—	0°	—	—
θ ₂	11°	12°	13°	11°	12°	13°
θ ₃	11°	12°	13°	11°	12°	13°
ccc	0.08			0.003		

Fig.2-3 RK3126C LQFP176 Package Dimension

2.3.1 Pin Map

Pin Number	Pin Name	Pin Number	Pin Name
176	DDR_VDD	176	DDR_VDD
175	DDR_A3	175	DDR_A3
174	DDR_BA2	174	DDR_BA2
173	DDR_WEN	173	DDR_WEN
172	DDR_CSN0	172	DDR_CSN0
171	DDR_CSN1	171	DDR_CSN1
170	DDR_CASN	170	DDR_CASN
169	DDR_RASN	169	DDR_RASN
168	DDR_VDD	168	DDR_VDD
167	DDR_CLK	167	DDR_CLK
166	DDR_CLK_N	166	DDR_CLK_N
165	DDR_ODT0	165	DDR_ODT0
164	DDR_CKE	164	DDR_CKE
163	DDR_A10	163	DDR_A10
162	DDR_BA0	162	DDR_BA0
161	DDR_BA1	161	DDR_BA1
160	CVDD	160	CVDD
159	DDR_A12	159	DDR_A12
158	DDR_A4	158	DDR_A4
157	DDR_A1	157	DDR_A1
156	DDR_A11	156	DDR_A11
155	DDR_A15	155	DDR_A15
154	DDR_A14	154	DDR_A14
153	DDR_A6	153	DDR_A6
152	DDR_A8	152	DDR_A8
151	DDR_DQ3	151	DDR_DQ3
150	DDR_DM0	150	DDR_DM0
149	DDR_DQ1	149	DDR_DQ1
148	DDR_VDD	148	DDR_VDD
147	DDR_DQ8	147	DDR_DQ8
146	DDR_DQ7	146	DDR_DQ7
145	DDR_DQ4	145	DDR_DQ4
144	DDR_DQ6	144	DDR_DQ6
143	CVDD	143	CVDD
142	DDR_DQS0_N	142	DDR_DQS0_N
141	DDR_DQS0	141	DDR_DQS0
140	DDR_VDD	140	DDR_VDD
139	DDR_DQ0	139	DDR_DQ0
138	DDR_DQ2	138	DDR_DQ2
137	CODEC_AOR	137	CODEC_AOR
136	CODEC_AVDD	136	CODEC_AVDD
135	CODEC_AOL	135	CODEC_AOL
134	CODEC_MICR	134	CODEC_MICR
133	CODEC_VCM	133	CODEC_VCM
1	DDR_A0		CVDD
2	DDR_A2		I2C0_SCL/GPIO0_A0
3	DDR_A5		I2C0_SDA/GPIO0_A1
4	DDR_A9		I2C1_SCL/GPIO0_A2
5	DDR_A13		I2C1_SDA/GPIO0_A3
6	DDR_A7		SDMMC0_CMD/GPIO1_B7
7	DDR_ODT1		VCCIO
8	DDR_DQ10		I2S_MCLK/GPIO1_A0
9	DDR_DQ8		I2S_SCLK/GPIO1_A1
10	DDR_VDD		I2S_LRCK_RX/GPS_CLK/GPIO1_A2
11	DDR_DQS1		I2S_SDO/GPS_MAG/GPIO1_A4
12	DDR_DQS1_N		I2S_SDI/GPS_SIGN/GPIO1_A5
13	CVDD		SPL_CLK/UART1_CTSN/GPIO1_B0
14	DDR_DQ14		SPL_TXD/UART1_TX/GPIO1_B1
15	DDR_DQ12		SPL_RXD/UART1_RX/GPIO1_B2
16	DDR_DQ15		SPL_CSN0/UART1_RTSN/GPIO1_B3
17	DDR_DQ13		SDMMC0_CLK0/GPIO1_C0
18	DDR_VDD		VCCIO
19	DDR_DQ9		SDMMC0_DET/GPIO1_C1
20	DDR_DM1		SDMMC0_D0/GPIO1_C2
21	DDR_DQ11		SDMMC0_D1/GPIO1_C3
22	C/DPLL_DVDD12		SDMMC0_D2/GPIO1_C4

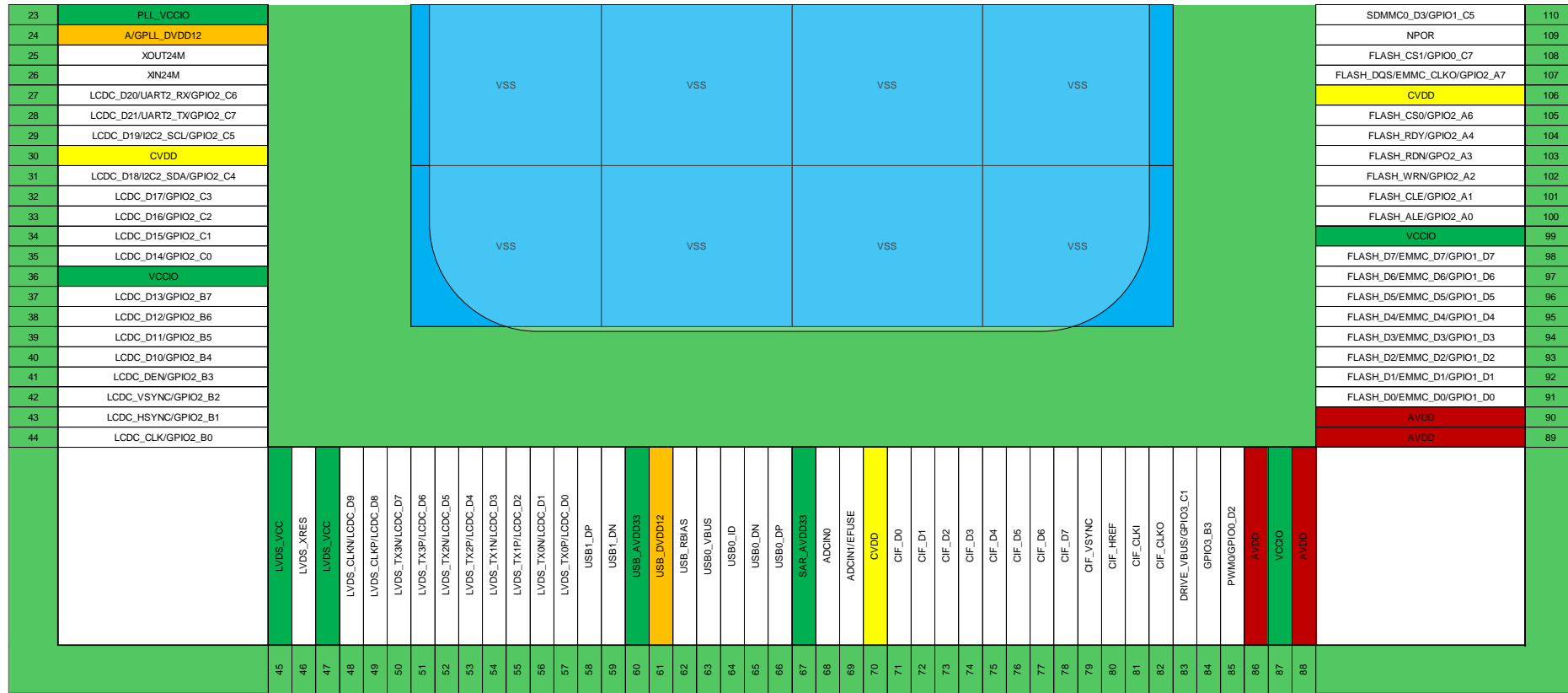

Fig.2-4 RK3126C LQFP176 Pin Map

2.4 Pin Description

In this chapter, the pin description will be divided into two parts, one is all power/ground descriptions in Table 1-1, include analog power/ground, another is all the function signals descriptions in Table 1-2, also include analog power/ground.

2.4.1 RK3126C power/ground IO descriptions

Table 2-1 RK3126C Power/Ground IO information

Pin Name	Pin No.	Descriptions
GND	ePAD	Internal Core Ground and Digital IO Ground
AVDD	86,88,89,90,91	Internal CPU Power
CVDD	13,29,69,108,126,161	Core digital Power Supply
VCCIO	35,87,100,115	IO Power Supply
DDR_VDD	10,18,142,150,169	DDR Power Supply
DDR_VSS	139	DDR Power Ground
XVSS	27	PLL Power Ground
C/DPLL_DVDD11	22	CODEC/DDR PLL Digital Power
A/GPLL_DVDD11	24	ARM/GENERAL PLL Digital Power
PLL_VCC33	23	PLL Analog Supply
SAR_AVDD33	66	SAR-ADC Analog Power Supply
USB_DVDD11	60	USB Digital Power Supply
USB_AVDD33	59	USB Analog Power Supply
CODEC_AVDD	137	Audio Codec Analog Power Supply
CODEC_AVSS	134,138	Audio Codec Ground
LVDS_VCC	44,46	LCD/LVDS Analog Supply

2.4.2 RK3126C function IO descriptions

Table 2-2 RK3126C IO descriptions

Pin No.	Pin Name	func1	func2	pad ^① type	driving ^②	Pull up /down	Reset State ③
1	DDR_A0			O	N/A	N/A	O
2	DDR_A2			O	N/A	N/A	O
3	DDR_A5			O	N/A	N/A	O
4	DDR_A9			O	N/A	N/A	O
5	DDR_A13			O	N/A	N/A	O
6	DDR_A7			O	N/A	N/A	O
7	DDR_ODT1			O	N/A	N/A	O
8	DDR_DQ10			I/O	N/A	N/A	I
9	DDR_DQ8			I/O	N/A	N/A	I
11	DDR_DQS1			I/O	N/A	N/A	I
12	DDR_DQS1_N			I/O	N/A	N/A	I
14	DDR_DQ14			I/O	N/A	N/A	I
15	DDR_DQ12			I/O	N/A	N/A	I
16	DDR_DQ15			I/O	N/A	N/A	I
17	DDR_DQ13			I/O	N/A	N/A	I
19	DDR_DQ9			I/O	N/A	N/A	I
20	DDR_DM1			I/O	N/A	N/A	I
21	DDR_DQ11			I/O	N/A	N/A	I
25	XOUT24M			O	N/A	N/A	O
26	XIN24M			I	N/A	N/A	I
28	GPIO2_C5/LCDC_D19/EBC_SDSHR/I2C2_SCL			I/O	8	down	I
30	GPIO2_C4/LCDC_D18/EBC_GDRL/I2C2_SDA			I/O	8	down	I
31	GPIO2_C3/LCDC_D17/EBC_GDPWR0			I/O	8	down	I
32	GPIO2_C2/LCDC_D16/EBC_GDSP			I/O	8	down	I
33	GPIO2_C1/LCDC_D15/EBC_GDOE			I/O	8	down	I
	GPIO2_C0/LCDC_D14/EBC_VCOM			I/O	8	down	I
36	GPIO2_B7/LCDC_D13/EBC_SDCE5			I/O	8	down	I
37	GPIO2_B6/LCDC_D12/EBC_SDCE4			I/O	8	down	I
38	GPIO2_B5/LCDC_D11/EBC_SDCE3			I/O	8	down	I

Pin No.	Pin Name	func1	func2	pad ^① type	driving ^②	Pull up /down	Reset State ③
39	GPIO2_B4/LCDC_D10/EBC_SDCE2			I/O	8	down	I
40	GPIO2_B3/LCD_DEN/EBC_GDCLK			I/O	8	down	I
41	GPIO2_B2/LCD_VSYNC/EBC_SDOE			I/O	8	down	I
42	GPIO2_B1/LCDC_HSYNC/EBC_SDLE			I/O	8	down	I
43	GPIO2_B0/LCDC_CLK/EBC_SDCLK			I/O	12	down	I
45	LVDS_EXTR			A	N/A	N/A	N/A
47	LCDC_D9/LVDS_CLKN/EBC_SDCE1/MI PI_CLKN			A	N/A	N/A	N/A
48	LCDC_D8/LVDS_CLKP/EBC_SDCE0/MI PI_CLKP			A	N/A	N/A	N/A
49	LCDC_D7/LVDS_TX3N/EBC_SDDO7/MI PI_D3N			A	N/A	N/A	N/A
50	LCDC_D6/LVDS_TX3P/EBC_SDDO6/MI PI_D3P			A	N/A	N/A	N/A
51	LCDC_D5/LVDS_TX2N/EBC_SDDO5/MI PI_D2N			A	N/A	N/A	N/A
52	LCDC_D4/LVDS_TX2P/EBC_SDDO4/MI PI_D2P			A	N/A	N/A	N/A
53	LCDC_D3/LVDS_TX1N/EBC_SDDO3/MI PI_D1N			A	N/A	N/A	N/A
54	LCDC_D2/LVDS_TX1P/EBC_SDDO2/MI PI_D1P			A	N/A	N/A	N/A
55	LCDC_D1/LVDS_TX0N/EBC_SDDO1/MI PI_D0N			A	N/A	N/A	N/A
56	LCDC_D0/LVDS_TX0P/EBC_SDDO0/MI PI_D0P			A	N/A	N/A	N/A
57	HOST_DP			A	N/A	N/A	N/A
58	HOST_DM			A	N/A	N/A	N/A
61	USB_EXTR			A	N/A	N/A	N/A
62	OTG_VBUS			A	N/A	N/A	N/A
63	OTG_ID			A	N/A	N/A	N/A
64	OTG_DM			A	N/A	N/A	N/A
65	OTG_DP			A	N/A	N/A	N/A
67	ADCIN0			A	N/A	N/A	N/A
68	ADCIN3/EFUSE			A	N/A	N/A	N/A

Pin No.	Pin Name	func1	func2	pad ^① type	driving ^②	Pull up /down	Reset State ③
70	CIF_D0/TS_D0			I	N/A	down	I
71	CIF_D1/TS_D1			I	N/A	down	I
72	CIF_D2/TS_D2			I	N/A	down	I
73	CIF_D3/TS_D3			I	N/A	down	I
74	CIF_D4/TS_D4			I	N/A	down	I
75	CIF_D5/TS_D5			I	N/A	down	I
76	CIF_D6/TS_D6			I	N/A	down	I
77	CIF_D7/TS_D7			I	N/A	down	I
78	CIF_VSYNC/TS_SYNC			I	N/A	down	I
79	CIF_HREF/TS_FAIL			I	N/A	down	I
80	CIF_CLKI/TS_VALID			I	N/A	down	I
81	CIF_CLKO/TS_CLKO			I/O	4	down	I
82	GPIO3_C1/DRIVE_VBUS/PMIC_SLEEP			I/O	4	down	I
83	GPIO3_B3/CIF_PDN			I/O	4	up	I
84	GPIO0_D2/PWM0			I/O	4	down	I
85	GPIO0_D3/PWM1			I/O	4	down	I
92	GPIO1_C6/FLASH_CS2/EMMC_CMD			I/O	4	up	I
93	GPIO1_D0/FLASH_D0/EMMC_D0/SFC_SIO0			I/O	8	up	I
94	GPIO1_D1/FLASH_D1/EMMC_D1/SFC_SIO1			I/O	8	up	I
95	GPIO1_D2/FLASH_D2/EMMC_D2/SFC_SIO2			I/O	8	up	I
96	GPIO1_D3/FLASH_D3/EMMC_D3/SFC_SIO3			I/O	8	up	I
97	GPIO1_D4/FLASH_D4/EMMC_D4/SPI_RXD			I/O	8	up	I
98	GPIO1_D5/FLASH_D5/EMMC_D5/SPI_TXD			I/O	8	up	I
99	GPIO1_D6/FLASH_D6/EMMC_D6/SPI_CSN0			I/O	8	up	I
100	GPIO1_D7/FLASH_D7/EMMC_D7/SPI_CSN1			I/O	8	up	I
102	GPIO2_A0/FLASH_ALE/SPI_CLK			I/O	8	down	I
103	GPIO2_A1/FLASH_CLE			I/O	8	down	I

Pin No.	Pin Name	func1	func2	pad ^① type	driving ^②	Pull up /down	Reset State ③
104	GPIO2_A2/FLASH_WRN/SFC_CSN0			I/O	8	up	I
105	GPIO2_A3/FLASH_RDN/SFC_CSN1			I/O	8	up	I
106	GPIO2_A4/FLASH_RDY/EMMC_CMD/SF C_CLK			I/O	8	up	I
107	GPIO2_A6/FLASH_CS0			I/O	8	up	I
109	GPIO2_A7/FLASH_DQS/EMMC_CLKO			I/O	8	up	I
110	NPOR			I	N/A	down	I
111	GPIO1_C5/SDMMC0_D3/JTAG_TMS			I/O	4	up	I
112	GPIO1_C4/SDMMC0_D2/JTAG_TCK			I/O	4	up	I
113	GPIO1_C3/SDMMC0_D1/UART2_RX			I/O	4	up	I
114	GPIO1_C2/SDMMC0_D0/UART2_TX			I/O	4	up	I
116	GPIO1_C0/SDMMC0_CLKO			I/O	4	down	I
117	GPIO1_B3/UART1_RTSN/SPI_CSN0			I/O	4	up	I
118	GPIO1_B2/UART1_RX/SPI_RXD			I/O	4	up	I
119	GPIO1_B1/UART1_TX/SPI_TXD			I/O	4	up	I
120	GPIO1_B0/UART1_CTSN/SPI_CLK			I/O	4	up	I
121	GPIO1_A5/I2S_SDI/SDMMC1_D3			I/O	4	down	I
122	GPIO1_A4/I2S_SDO/SDMMC1_D2			I/O	4	down	I
123	GPIO1_A2/I2S_LRCK_RX/SDMMC1_D1 for Version A			I/O	4	up	I
123	GPIO1_A2/I2S_LRCK_RX/SDMMC1_D1 for Version B			I/O	4	down	I
124	GPIO1_A1/I2S_SCLK/SDMMC1_D0			I/O	4	down	I
125	GPIO1_A0/I2S_MCLK/SDMMC1_CLKO/ XIN_32K			I/O	4	down	I
127	GPIO1_B7/SDMMC0_CMD			I/O	4	up	I
128	GPIO0_A3/I2C1_SDA/SDMMC1_CMD			I/O	4	up	I
129	GPIO0_A2/I2C1_SCL			I/O	4	up	I
130	GPIO0_A1/I2C0_SDA			I/O	4	up	I
131	GPIO0_A0/I2C0_SCL			I/O	4	up	I
132	CODEC_VCM			A	N/A	N/A	N/A
133	CODEC_MIC			A	N/A	N/A	N/A
135	CODEC_AOL			A	N/A	N/A	N/A
137	CODEC_AOR			A	N/A	N/A	N/A
140	DDR_DQ2			I/O	N/A	N/A	I

Pin No.	Pin Name	func1	func2	pad ^① type	driving ^②	Pull up /down	Reset State ③
141	DDR_DQ0			I/O	N/A	N/A	I
143	DDR_DQS0			I/O	N/A	N/A	I
144	DDR_DQS0_N			I/O	N/A	N/A	I
145	DDR_DQ6			I/O	N/A	N/A	I
146	DDR_DQ4			I/O	N/A	N/A	I
147	DDR_DQ7			I/O	N/A	N/A	I
148	DDR_DQ5			I/O	N/A	N/A	I
150	DDR_DQ1			I/O	N/A	N/A	I
151	DDR_DM0			I/O	N/A	N/A	I
152	DDR_DQ3			I/O	N/A	N/A	I
153	DDR_A8			O	N/A	N/A	O
154	DDR_A6			O	N/A	N/A	O
155	DDR_A14			O	N/A	N/A	O
156	DDR_A15			O	N/A	N/A	O
157	DDR_A11			O	N/A	N/A	O
158	DDR_A1			O	N/A	N/A	O
159	DDR_A4			O	N/A	N/A	O
160	DDR_A12			O	N/A	N/A	O
162	DDR_BA1			O	N/A	N/A	O
163	DDR_BA0			O	N/A	N/A	O
164	DDR_A10			O	N/A	N/A	O
165	DDR_CKE			O	N/A	N/A	O
166	DDR_ODT0			O	N/A	N/A	O
167	DDR_CLK_N			O	N/A	N/A	O
168	DDR_CLK			O	N/A	N/A	O
170	DDR_RASN			O	N/A	N/A	O
171	DDR_CASN			O	N/A	N/A	O
172	DDR_CSN1			O	N/A	N/A	O
173	DDR_CSN0			O	N/A	N/A	O
174	DDR_WEN			G	N/A	N/A	O
175	DDR_BA2			O	N/A	N/A	O
176	DDR_A3			O	N/A	N/A	O

Notes :

① : Pad types : I = input , O = output , I/O = input/output (bidirectional) ,

AP = Analog Power , AG = Analog Ground, DP = Digital Power , DG = Digital Ground, A = Analog

Ⓜ Output Drive Unit is mA , only Digital IO have drive value

Ⓜ Reset state : I = input without any pull resistor , O = output without any pull resistor ,

Ⓜ It is die location. For examples, "Left side" means that all the related IOs are always in left side of die

Ⓜ Power supply means that all the related IOs is in these IO power domain. If multiple powers is included, they are connected together in one IO power ring

Rockchip Confidential

2.4.3 IO pin name descriptions

This sub-chapter will focus on the detailed function description of every pins based on different interface.

Table 2-3 RK3126C IO function description list

Interface	Pin Name	Direction	Description
Misc	XIN24M	I	Clock input of 24MHz crystal
	XOUT24M	O	Clock output of 24MHz crystal
	NPOR	I	Power on reset for chip

Interface	Pin Name	Direction	Description
Debug	TCK	I	JTAG interface clock input/SWD interface clock input
	TMS	I/O	JTAG interface TMS input/SWD interface data out

Interface	Pin Name	Direction	Description
SD/MMC Host Controller	sdmmc_clkout	O	sdmmc card clock.
	sdmmc_cmd	I/O	sdmmc card command output and reponse input.
	sdmmc_data <i>i</i> (<i>i</i> =0~3)	I/O	sdmmc card data input and output.

Interface	Pin Name	Direction	Description
SDIO Host Controller	sdio_clkout	O	sdio card clock.
	sdio_cmd	I/O	sdio card command output and reponse input.
	sdio_data <i>i</i> (<i>i</i> =0~3)	I/O	sdio card data input and output.

Interface	Pin Name	Direction	Description
eMMC Interface	emmc_clkout	O	emmc card clock.
	emmc_cmd	I/O	emmc card command output and reponse input.
	emmc_data <i>i</i> (<i>i</i> =0~7)	I/O	emmc card data input and output.
	emmc_pwr_en	O	emmc card power-enable control signal
	emmc_rstn_out	O	emmc card reset signal

Interface	Pin Name	Direction	Description
DMC	CLK	O	Active-high clock signal to the memory device.
	CLK_N	O	Active-low clock signal to the memory device.
	CKE	O	Active-high clock enable signal to the memory device
	CSN <i>i</i> (<i>i</i> =0,1)	O	Active-low chip select signal to the memory device. AThere are two chip select.
	RASN	O	Active-low row address strobe to the memory device.

Interface	Pin Name	Direction	Description
	CASN	O	Active-low column address strobe to the memory device.
	WEN	O	Active-low write enable strobe to the memory device.
	BA _i (<i>i</i> =0,1,2)	O	Bank address signal to the memory device.
	A _i (<i>i</i> =0~15)	O	Address signal to the memory device.
	DQ _i (<i>i</i> =0~15)	I/O	Bidirectional data line to the memory device.
	DQS0 DQS1	I/O	Active-high bidirectional data strobes to the memory device.
	DQS0_N DQS1_N	I/O	Active-low bidirectional data strobes to the memory device.
	DM _i (<i>i</i> =0,1)	O	Active-low data mask signal to the memory device.
	ODT _i (<i>i</i> =0,1)	O	On-Die Termination output signal for two chip select.

Interface	Pin Name	Direction	Description
NandC	flash_wp	O	Flash write-protected signal
	flash_ale	O	Flash address latch enable signal
	flash_cle	O	Flash command latch enable signal
	flash_wrn	O	Flash write enable and clock signal
	flash_rdn	O	Flash read enable and write/read signal
	flash_data _i (<i>i</i> =0~7)	I/O	8bits of flash data inputs/outputs signal
	flash_dqs	I/O	Flash data strobe signal
	flash_rdy	I	Flash ready/busy signal
	flash_cs _n (<i>i</i> =0,2)	O	Flash chip enable signal for chip <i>i</i> , <i>i</i> =0,2

Interface	Pin Name	Direction	Description
SPI Controller	spi_clk	I/O	spi serial clock
	spi_cs _n (<i>i</i> =0,1)	I/O	spi chip select signal, low active
	spi_txd	O	spi serial data output
	spi_rxd	I	spi serial data input

Interface	Pin Name	Direction	Description
LCDC	lcdc_dclk	O	LCDC RGB interface display clock out, MCU i80 interface RS signal
	lcdc_vsync	O	LCDC RGB interface vertical sync pulse, MCU i80 interface CSN signal
	lcdc_hsync	O	LCDC RGB interface horizontal sync pulse, MCU i80 interface WEN signal
	lcdc_den	O	LCDC RGB interface data enable, MCU i80 interface REN signal
	lcdc_data <i>i</i> (<i>i</i> =0~19)	I/O	LCDC data output/input

Interface	Pin Name	Direction	Description
Camera IF	cif_clk	I	Camera interface input pixel clock
	cif_clkout	O	Camera interface output work clock
	cif_vsync	I	Camera interface vertical sync signal
	cif_href	I	Camera interface horizontal sync signal
	cif_data <i>i</i> (<i>i</i> =0~7)	I	Camera interface 8-bit input pixel data

Interface	Pin Name	Direction	Description
PWM	pwm1	O	Pulse Width Modulation output
	pwm0	O	Pulse Width Modulation output

Interface	Pin Name	Direction	Description
I2C	i2c0_sda	I/O	I2C0 data
	i2c0_scl	I/O	I2C0 clock
	i2c1_sda	I/O	I2C1 data
	i2c1_scl	I/O	I2C1 clock
	i2c2_sda	I/O	I2C2 data
	i2c2_scl	I/O	I2C2 clock

Interface	Pin Name	Direction	Description
UART	uart1_sin	I	UART1 serial data input
	uart1_sout	O	UART1 serial data output
	uart1_cts_n	O	UART1 clear to send
	uart1_rts_n	I	UART1 request to send
	uart2_sin	I	UART2 serial data input
	uart2_sout	O	UART2 serial data output

Interface	Pin Name	Direction	Description
USB OTG2.0 /HOST 2.0	OTG_DP	I/O	USB OTG 2.0 Data signal DP
	OTG_DM	I/O	USB OTG 2.0 Data signal DM
	OTG_VBUS	N/A	USB OTG 2.0 5V power supply pin
	OTG_ID	I	USB OTG 2.0 ID indicator
	HOST_DP	I/O	USB HOST 2.0 Data signal DP
	HOST_DM	I/O	USB HOST 2.0 Data signal DM
	USB_EXTR	N/A	133 Ohm Reference external resistance

Interface	Pin Name	Direction	Description
-----------	----------	-----------	-------------

Audio Codec	MIC	I	Microphone input
	VCM	I	Decoupling for voltage reference
	AOL	O	Left channel DAC driver amplifier output
	AOR	O	Right channel DAC driver amplifier output

Interface	Pin Name	Direction	Description
LVDS	lvds/mipi_extr	I	Connected to external 12Kohm through bonding pad
	lvds_txp_n	O	Transmit serial data out(Positive), n=1~4
	lvds_txn_n	O	Transmit serial data out(Negative), n=1~4
	lvds_clkp	O	Output clock
	lvds_clkn	O	Output clock(Negative)

Interface	Pin Name	Direction	Description
MIPI	lvds/mipi_extr	I	Connected to external 12Kohm through bonding pad
	mipiDiP (i=0~3)	O	Transmit serial data out(Positive), i=0~3
	mipiDiN (i=0~3)	O	Transmit serial data out(Negative), i=0~3
	mipi_clkp	O	Output clock(Positive)
	mipi_clkn	O	Output clock(Negative)

Interface	Pin Name	Direction	Description
SAR-ADC	Saradc_ain <i>i</i> (i = 0, 2)	N/A	SAR-ADC input signal for 3 channel

Interface	Pin Name	Direction	Description
eFuse	efuse_vp	N/A	eFuse program and sense power

2.4.4 RK3126C IO Type

The following list shows IO type except DDR IO and all of Power/Ground IO .

Table 2-4 RK3126C IO Type List

Type	Diagram	Description	Pin Name
A		Analog IO Cell with IO voltage	EFUSE_VP
B		Dedicated Power supply to Internal Macro with IO voltage	SARADC_AIN[2:0]
C		Crystal Oscillator with internal register	XIN24M/XOUT24M

Type	Diagram	Description	Pin Name
D		<p>CMOS 3-state output pad with controllable input and controllable pulldown</p>	<p>Part of digital GPIO (PBCDxRNC)</p>
E		<p>CMOS 3-state output pad with controllable input and controllable pullup</p>	<p>Part of digital GPIO (PBCUxRNC)</p>
F		<p>controllable input pad with controllable pulldown</p>	<p>Part of digital GPIO (PICDRNC)</p>
G		<p>controllable input pad with controllable pullup</p>	<p>Part of digital GPIO (PICURNC)</p>

Chapter 3 Electrical Specification

3.1 Absolute Maximum Ratings

Table 3-1 RK3126C absolute maximum ratings

Parameters	Related Power Group	Max	Unit
DC supply voltage for Internal digital logic	AVDD,CVDD,	TBD	V
DC supply voltage for Internal digital logic	USB_DVDD11,LVDS_DVDD11	1.2 1	V
DC supply voltage for Digital GPIO (except for SAR-ADC, PLL, USB, DDR IO)	VCCIO	3.6 3	V
DC supply voltage for DDR IO	VCC_DDR	1.9 5	V
DC supply voltage for Analog part of SAR-ADC and PLL	SAR_AVDD33,PLL_VCCIO	3.6 3	V
DC supply voltage for Analog part of PLL	A/GPLL_DVDD11,C/DPLL_DVDD11	1.2 1	V
DC supply voltage for Analog part of USB OTG/Host2.0	USB_AVDD33	3.6 3	V
DC supply voltage for Analog part of Acodec	CODEC_AVDD	3.6 3	V
DC supply voltage for Analog part of LVDS	LVDS_VCC	3.6 3	V
Analog Input voltage for SAR-ADC		2.7 5	V
Analog Input voltage for DP/DM/VBUS of USB OTG/Host2.0		5.2 5	V
Digital input voltage for input buffer of GPIO		3.6 3	V
Digital output voltage for output buffer of GPIO		3.6 3	V
Storage Temperature	Tstg	125	°C
Max Conjunction Temperature	Tj	125	°C

Absolute maximum ratings specify the values beyond which the device may be damaged permanently. Long-term exposure to absolute maximum ratings conditions may affect device reliability.

3.2 Recommended Operating Conditions

Table 3-2 RK3126C recommended operating conditions

Parameters	Symbol	Min	Typ	Max	Units
Internal digital Core Power	AVDD	0.9	TBD	TBD	V
Internal digital logic Power	CVDD,USB_DVDD11,LVDS_DVDD11	0.9	1.1	1.21	V
Digital GPIO Power	VCCIO	2.97	3.3	3.63	V
DDR IO (DDR3 mode) Power	VCC_DDR	1.425	1.5	1.575	V

Parameters	Symbol	Min	Typ	Max	Units
DDR IO (DDR3L mode) Power	VCC_DDR	1.28	1.35	1.45	V
PLL Analog Power	PLL_VCCIO	2.97	3.3	3.63	V
PLL Analog Power	A/GPLL_DVDD11,C/DPLL_DVDD11	0.99	1.1	1.21	V
SAR-ADC Analog Power	SAR_AVDD33	2.97	3.3	3.63	V
USB OTG/Host2.0 Analog Power(3.3V)	USB_AVDD33	2.97	3.3	3.63	V
USB OTG/Host2.0 external resistor	EXTR	122	135	147	Ohm
Acodec Analog Power	CODEC_AVDD	2.97	3.3	3.63	V
EFUSE programming voltage		2.25	2.5	2.75	V
PLL input clock frequency			24		MHz
Ambient Operating Temperature ②	Ta	0	25	80	°C

Notes : ① Symbol name is same as the pin name in the io descriptions

② with the reference software setup, the reference software will limit the chipset temperature about 80 °C

3.3 DC Characteristics

Table 3-3 RK3126C DC Characteristics

Parameters	Symbol	Min	Typ	Max	Units	
Digital GPIO	Input Low Voltage	Vil	-0.3	0	0.8	V
	Input High Voltage	Vih	2	3.3	3.6	V
	Output Low Voltage	Vol		0	0.4	V
	Output High Voltage	Voh	2.4	3.3		V
	Threshold Point	Vt	1.21	1.42	1.64	V
	Schmitt trig Low to High threshold point	Vt+	1.36	1.6	1.86	V
	Schmitt trig High to Low threshold point	Vt-	0.93	1.09	1.3	V
	Pullup Resistor	Rpu	33	41	62	Kohm
	Pulldown Resistor	Rpd	33	42	68	Kohm
DDR IO (Data)	DC Input High Voltage	Vih(DC)	VREF + 0.1		VDDQ+ 0.4	V
	AC Input High Voltage	Vih(AC)	VREF + 0.15		VDDQ+ 0.4	V
	DC Input Low Voltage	Vil(DC)	-0.4		VREF - 0.1	V
	AC Input Low Voltage	Vil(AC)	-0.4		VREF + 0.15	V
	Differential input logic high	Vihdiff	+0.2		VDDQ + 0.4	V
	Differential input logic low	Vildiff	-0.4		-0.2	V
	Output High Voltage	Voh	0.9 * VDDQ	VDDQ		V

Parameters		Symbol	Min	Typ	Max	Units
	Output Low Voltage	Vol		0	0.1 * VDDQ	V
DDR IO (Address and command)	Output High Voltage	Voh	0.9 * VDDQ	VDDQ	VDDQ+0.4	V
	Output Low Voltage	Vol	-0.4	0	0.1 * VDDQ	V
DDR IO (Clock)	DC output voltage	Von	-0.4	VDDQ	VDDQ+0.4	V
	DC output Differential voltage	Vod(DC)	0.4 * VDDQ		VDDQ+0.6	V
	AC output Differential voltage	Vod(AC)	0.6 * VDDQ		VDDQ+0.6	V
	AC differential crossing voltage	Vox	0.4 * VDDQ	0.5*V DDQ	0.6 * VDDQ	V
SAR-ADC	Input Range	2-channel single-ended input	0		SAR_AVD D33	V
PLL	Input High Voltage	Vih_pll	0.8*DVDD_i PLL (i=A,D,CG)	DVDD_iPLL (i=A,D,CG)	DVDD_iPLL (i=A,D,CG)	V
	Input Low Voltage	Vil_pll	0	0	0.2*DVDD_iPLL (i=A,D,CG)	V

3.4 Recommended Operating Frequency

Table 3-4 Recommended operating frequency for PLL and oscillator domain

Parameter	Condition	Symbol	MIN	TYP	MAX	Unit
XIN Oscillator	3.3V , 25 °C	XIN24M		24		MHz
	3.6V , -40 °C			24		
	3.0V , 125 °C			24		
DDR PLL	1.1V , 25 °C	ddr_pll_clk			1390	MHz
	1.21V , -40 °C				1690	
	0.99V , 125 °C				800	
ARM PLL	1.1V , 25 °C	arm_pll_clk			1530	MHz
	1.21V , -40 °C				1960	
	0.99V , 125 °C				800	
CODEC PLL	1.1V , 25 °C	cocec_pll_clk			1030	MHz
	1.21V , -40 °C				1380	
	0.99V , 125 °C				600	

Parameter	Condition	Symbol	MIN	TYP	MAX	Unit
GENERAL PLL	1.1V , 25 °C	general_pll_clk			1010	MHz
	1.21V , -40 °C				1350	
	0.99V , 125 °C				600	

Table 3-5 Recommended operating frequency for CPU core

Parameter	Condition	Symbol	MIN	TYP	MAX	Unit
aCortex-A7	1.1V , 25 °C	CORE_SRC_CLK			1180	MHz
	1.21V , -40 °C				1470	
	0.99V , 125 °C				775	
	1.1V , 25 °C	aclk_core_pre			678	MHz
	1.21V , -40 °C				890	
	0.99V , 125 °C				410	
	1.1V , 25 °C	clk_core_peri			330	MHz
	1.21V , -40 °C				420	
	0.99V , 125 °C				200	

Table 3-6 Recommended operating frequency for PD_CPU domain

Parameter	Condition	Symbol	MIN	TYP	MAX	Unit
CPU AXI interconnect	1.1V , 25 °C	CPU_ACLK			520	MHz
	1.21V , -40 °C				710	
	0.99V , 125 °C				300	
	1.1V , 25 °C	CPU_HCLK			190	MHz
	1.21V , -40 °C				350	
	0.99V , 125 °C				150	
1.1V , 25 °C	CPU_PCLK			170	MHz	
1.21V , -40 °C				250		
0.99V , 125 °C				75		
DMC	1.1V , 25 °C	DDR_PHY1X_CLK			760	MHz
	1.21V , -40 °C				1000	
	0.99V , 125 °C				400	

Table 3-7 Recommended operating frequency for PD_PERI domain

Parameter	Condition	Symbol	MIN	TYP	MAX	Unit
PERI AXI interconnect	1.1V , 25 °C	PERI_ACLK			498	MHz
	1.21V , -40 °C				700	
	0.99V , 125 °C				300	
	1.1V , 25 °C	PERI_HCLK			259	MHz
	1.21V , -40 °C				330	
	0.99V , 125 °C				150	
	1.1V , 25 °C	PERI_PCLK			140	MHz
	1.21V , -40 °C				190	
0.99V , 125 °C				75		
NAND	1.1V , 25 °C	FLASH_HCLK			250	MHz
	1.21V , -40 °C				340	
	0.99V , 125 °C				150	
USB OTG	1.1V , 25 °C	UTMI_CLK_0/			30	MHz

Parameter	Condition	Symbol	MIN	TYP	MAX	Unit
	1.21V , -40 °C	UTMI_CLK_1			30	
	0.99V , 125 °C				30	
UART1	1.1V , 25 °C	UART1_CLK			50	MHz
	1.21V , -40 °C				50	
	0.99V , 125 °C				50	
SDMMC/SDIO	1.1V , 25 °C	MMC0_CLK/ SDIO_CLK			100	MHz
	1.21V , -40 °C				100	
	0.99V , 125 °C				100	
EMMC	1.1V , 25 °C	EMMC_CLK			100	MHz
	1.21V , -40 °C				100	
	0.99V , 125 °C				100	
I2S	1.1V , 25 °C	I2S_CLK			50	MHz
	1.21V , -40 °C				50	
	0.99V , 125 °C				50	
SPI0	1.1V , 25 °C	SPI0_CLK			50	MHz
	1.21V , -40 °C				50	
	0.99V , 125 °C				50	
SAR-ADC	1.1V , 25 °C	SARADC_CLK			12	MHz
	1.21V , -40 °C				12	
	0.99V , 125 °C				12	
Timer0/1	1.1V , 25 °C	TIMER0_CLK/ TIMER1_CLK			24	MHz
	1.21V , -40 °C				24	
	0.99V , 125 °C				24	
	1.1V , 25 °C	TIMER0_PCLK/ TIMER1_PCLK			140	MHz
	1.21V , -40 °C				190	
	0.99V , 125 °C				75	

Table 3-8 Recommended operating frequency for PD_VIO domain

Parameter	Condition	Symbol	MIN	TYP	MAX	Unit
Display AXI interconnection	1.1V , 25 °C	DISP_ACLK			530	MHz
	1.21V , -40 °C				720	
	0.99V , 125 °C				300	
	1.1V , 25 °C	DISP_HCLK			370	MHz
	1.21V , -40 °C				500	
	0.99V , 125 °C				200	
LCDC	1.1V , 25 °C	LCDC_DCLK			179	MHz
	1.21V , -40 °C				190	
	0.99V , 125 °C				160	
	1.1V , 25 °C	LCDC1_DCLK			230	MHz
	1.21V , -40 °C				290	
	0.99V , 125 °C				160	
CIF	1.1V , 25 °C	IO_CIF_CLKIN			100	MHz
	1.21V , -40 °C				100	
	0.99V , 125 °C				100	

Table 3-9 Recommended operating frequency PD_GPU domain

Parameter	Condition	Symbol	MIN	TYP	MAX	Unit
GPU	1.1V , 25 °C	GPU_ACLK			510	MHz
	1.21V , -40 °C				691	
	0.99V , 125 °C				300	

Table 3-10 Recommended operating frequency for PD_VIDEO domain

Parameter	Condition	Symbol	MIN	TYP	MAX	Unit
VIDEO	1.1V , 25 °C	VEPU_ACLK			520	MHz
	1.21V , -40 °C				690	
	0.99V , 125 °C				300	
	1.1V , 25 °C	hclk_vepu			320	MHz
	1.21V , -40 °C				400	
	0.99V , 125 °C				150	
	1.1V , 25 °C	VDPU_ACLK			520	MHz
	1.21V , -40 °C				690	
	0.99V , 125 °C				300	
	1.1V , 25 °C	hclk_vdpu			320	MHz
	1.21V , -40 °C				490	
	0.99V , 125 °C				150	

3.5 Electrical Characteristics for General IO

Table 3-11 RK3126C Electrical Characteristics for Digital General IO

Parameters	Symbol	Test condition	Min	Typ	Max	Units
Input leakage current	I _l	V _{in} = 3.3V or 0V	-10		10	uA
Tri-state output leakage current	I _{oz}	V _{out} = 3.3V or 0V	-10		10	uA

3.6 Electrical Characteristics for PLL

Table 3-12 RK3126C Electrical Characteristics for PLL

Parameters	Symbol	Test condition	Min	Typ	Max	Units
Fractional accuracy				24		bits
Input clock frequency	F _{in}	Normal mode	1		800	MHz
		Fractional mode	10		800	MHz
Output clock frequency	F _{out}	F _{out} = F _{vco} /POSTDIV ^① @3.3V/1.1V	12		2400	MHz
VCO operating range	F _{vco}	F _{vco} = F _{ref} * FBDIV ^① @3.3V/1.1V	600		2400	MHz
Lock time ^②	T _{lt}	F _{REF} =24M,REFDIV=1 @ 3.3V/1.1V,		41.7	66.7	us
AVDD Current consumption ^③		F _{vco} = 1GHz, @3.3V, 27°C		1	1.2	mA
DVDD Power consumption (normal mode)		@3.3V/1.1V, 27°C		1.3	1.56	uA/MHz

Parameters	Symbol	Test condition	Min	Typ	Max	Units
ddsvAVDD Power Down Leakage		@3.3V/1.1V, 27°C		10		nA
DVDD Power Down Leakage		@3.3V/1.1V, 27°C		10		uA
Output Duty Cycle		Even divides @ FOUT=1GHz(falling edge error is ±20ps)	48	50	52	%
		Odd divides @ FOUT=1GHz(falling edge error is ±30ps)	47	50	53	%
		FOUTvco at any frequency	45	50	55	%

Notes :

@REFDIV is the input divider value;

FBDIV is the feedback divider value;

POSTDIV is the output divider value

@Lock Time is 1000cycles of input clocks in typ, and 1500cycles of input clocks in max.

@Current scale as (Fvco/1GHz)^{1.5}

3.7 Electrical Characteristics for SAR-ADC

Table 3-13 RK3126C Electrical Characteristics for SAR-ADC

Parameters	Symbol	Test condition	Min	Typ	Max	Units
ADC resolution				10		bits
Conversion speed	Fs				1	MSPS
Differential Non Linearity	DNL				1	LSB
Integral Non Linearity	INL				1.5	LSB
Input Capacitance	CIN			1		pF
Sampling Clock	SOC				1	MHz
Main Clock Frequency	CLK				11	MHz
Data Latency				10		Clock Cycle
SNR plus Distortion(Up to 5th harmonic)	SINAD	Fin=1.03K Fin=499K		59.56 57.03		dB
Spurious-Free Dynamic Range	SFDR	Fin=1.03K Fin=499K		78.59 65.75		dB
Second-Harmonic Distortion	2HD	Fin=1.03K Fin=499K		- 93.32 - 70.76		dB
Third-Harmonic Distortion	3HD	Fin=1.03K Fin=499K		- 88.16 - 65.75		dB
Effective Number of Bits	ENOB	Fin=1.03K Fin=499K		9.55 9.18		Bits
Analog Supply Current(SARADC_AVDD)				580		uA

Parameters	Symbol	Test condition	Min	Typ	Max	Units
Digital Supply Current				30		uA
Power Down Current				0.5		uA

3.8 Electrical Characteristics for USB OTG/Host2.0 Interface

Table 3-14 RK3126C Electrical Characteristics for USB OTG/Host2.0 Interface

Parameters	Symbol	Test condition	Min	Typ	Max	Units
Output resistance	Rout	Classic mode HS mode	40.5	45	49.5	ohm
Output Capacitance	Cout				3	pF
Differential output signal high	Voh	Classic(LS/FS),Io=0mA	2.97	3.3	3.63	V
		Classic(LS/FS),Io=6mA	2.2	2.7		V
		HS mode,Io=0mA	360	400	440	mV
Differential output signal low	Vol	Classic(LS/FS),Io=0mA	-0.33	0	0.33	V
		Classic(LS/FS),Io=6mA		0.3	0.8	V
		HS mode,Io=0mA	-40	400	40	mV
Output Common Mode Voltage	VM	Classic(LS/FS) mode	1.45	1.65	1.85	V
		HS mode	0.175	0.2	0.225	V
Rise and fall time	Tr/Tf	LS mode	75	87.5	300	ns
		FS mode	4	12	20	ns
		HS mode	0.8	1.0	1.2	ns
Propagation delay(data to D+/D-)		LS mode	30		300	ns
		FS mode	0		12	ns
		HS mode		TBD		ns
Propagation delay(tx_en to D+/D-)	Tpzh/Tpzl	Classic(LS/FS) mode			2	ns
		HS mode			2	ns
Receiver sensitivity	Rsens	Classic(LS/FS) mode		±250		mV
		HS mode		±250		mV
Receiver common mode	RCM	Classic(LS/FS) mode	0.8	1.65	2.5	V
		HS mode(differential and squelch comparator)	0.1	0.2	0.3	V
		HS mode(disconnect comparator)	0.5	0.6	0.7	V
Input capacitance	Cin	Seen at D+ or D-			3	pF
Squelch threshold			100	112	150	mV
Disconnect threshold			570	590	625	mV
High output level	Voh			1.1		V
Low output level	Vol			0		V
Pulldown Resistor on DP/DM	Rpu		14.5	15	16	Kohm
Pullup Resistor on DP/DM	Rpd		2.35	2.4	2.5	Kohm
UID Pullup resistor			160	200	240	Kohm

3.9 Electrical Characteristics for DDR IO

Table 3-15 RK3126C Electrical Characteristics for DDR IO

Parameters		Symbol	Test condition	Min	Typ	Max	Units
DDR IO @DDR3 mode	DDR IO power standby current, ODT OFF		@ 1.5V , 125°C	N/A	N/A	N/A	uA
	Input leakage current, SSTL mode, unterminated		@ 1.5V , 125°C	N/A	N/A	N/A	uA
DDR IO @DDR3L mode	Input leakage current		@ 1.35V , 125°C	N/A	N/A	N/A	uA
	DDR IO power quiescent current		@ 1.35V , 125°C	N/A	N/A	N/A	uA

3.10 Electrical Characteristics for LVDS

Parameters	Symbol	Test condition	Min	Typ	Max	Units
Output voltage low, V_{oa} or V_{ob}	V_{ol}	$R_{load}=100\text{ohm}\pm 1\%$	925		N/A	mV
Output voltage high, V_{oa} or V_{ob}	V_{oh}	$R_{load}=100\text{ohm}\pm 1\%$	N/A		1475	mV
Output differential voltage	$ V_{od} $	$R_{load}=100\text{ohm}\pm 1\%, R_s=0V$	250		450	mV
		$R_{load}=100\text{ohm}\pm 1\%, R_s=V_{DD}$	150		250	mV
Output offset voltage	V_{os}	$R_{load}=100\text{ohm}\pm 1\%$	1125		1375	mV
Change in $ V_{od} $ between '0' and '1'	$ \Delta V_{od} $	$R_{load}=100\text{ohm}\pm 1\%$			50/150	mV
change in V_{os} between '0' and '1'	ΔV_{os}	$R_{load}=100\text{ohm}\pm 1\%$			50	mV
Output current	I_{sa}, I_{sb}	Transmitter shorten to ground			24	mA
Output current	I_{sab}	Transmitter shorten to ground			12	mA
Leakage current	$I_{leakage}$	Power down	-10			uA
Clock in/out frequency	Clk_freq		20		170	MHz
Clock out duty cycle	Clk_dco			57		%
Data(Dn_m) setup to CK_REF	T_{ts}		2			ns
Data(Dn_m) hold to CK_REF	T_{th}		0.5			ns
Serial-Data Skew to $Clkout$ edge	$SDs dew$		-200	0	200	ps

3.11 Electrical Characteristics for eFuse

Table 3-16 RK3126C Electrical Characteristics for eFuse

Parameters	Symbol	Test condition	Min	Typ	Max	Units
Burn voltage	VQPS		2.25	2.5	2.75	V

Parameters	Symbol	Test condition	Min	Typ	Max	Units
Programming voltage	Vpgm			VQPS		V
Active mode	Iactive	STROBE high		2.53		mA
standby mode	Istandby			0.4		uA
Peak program current	Iprog			20.8		mA

3.12 Hardware Guideline

3.12.1 Reference design for RK3126C oscillator PCB connection

RK3126C only use one oscillator, and its typical clock frequency is 24MHz. The oscillator will provide input clock to four on-chip PLLs.

- External reference circuit for oscillators with 24MHz input

In the following diagram ,Rf is used to bias the inverter in the high gain region. The recommend value is 1Mohm.

Rd is used to increase stability, low power consumption, suppress the gain in high frequency region and also reduce -Rd of the oscillator. Thus, proper Rd cannot be too large to cease the loop oscillating.

C1 and C2 are deciding regard to the crystal or resonator CL specification.

the value for Rf,Rd,C1,C2 must be adjusted a little to improve performance of oscillator based on real crystal model .

In RK3126C, the crystal oscillator I/O cells have embedded internal resistor, so we need not add feedback resistor (Rf) as above description.

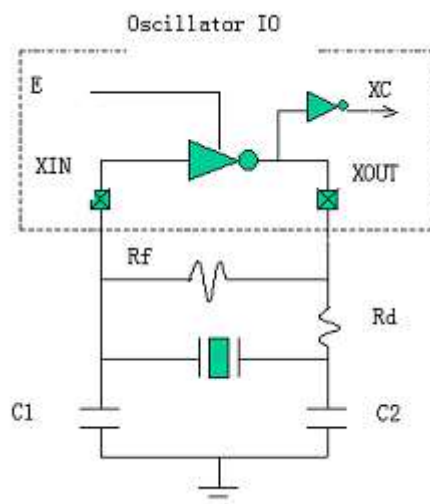

Fig.3-1 External Reference Circuit for 24MHzOscillators

3.12.2 Reference design for PLL PCB connection

The following reference design is suitable for PLL in RK3126C.

For optimal jitter performance it is suggested to place external decoupling capacitors on the board between PLL_DVDD-VSS(XVSS) and PLL_VCCIO-VSS(XVSS) . VDDREF is typically connected to the global chip supply and does not require dedicated decoupling.

It is recommended to use at least one large capacitor (e.g. 4.7uF) capacitor for each separate supply. Additionally, a 100nF and 10nF capacitor may be placed in parallel since the lead inductance of the 4.7uF capacitor may be large.

Capacitors with minimal lead inductance should be selected. Ceramic type capacitors work

well. The capacitors should be placed as close to the package pins as possible. No series impedance should be added anywhere on the board, and impedance to the voltage source should be minimized.

3.12.3 Reference design for USB OTG/Host2.0 connection

In RK3126C there are USB OTG and USB Host2.0 interface, and they share a common PHY.

- Decouple Capacitance

We should include decoupling and bypass capacitors at each power pin in the layout. These are shown schematically in Figure 1-9. Place these components as closely as possible to the power pins.

- Differential Lines

The differential lines should be routed together, minimizing the number of vias through which the signal lines are routed. Layout the differential pairs with controlled impedance of 90 ohm differential.

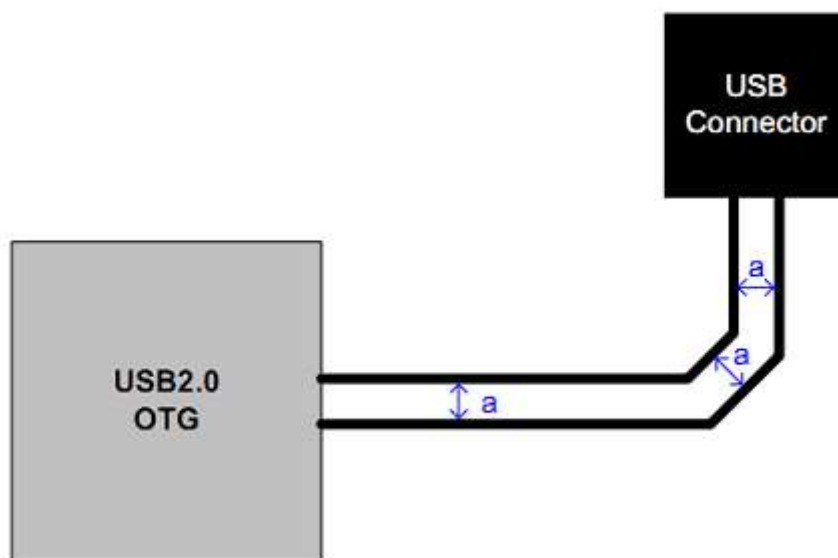

Fig.3-2 RK3126C USB OTG/Host2.0 differential lines requirement.

If high-speed signals are routed on the Top layer, best results will be obtained if the Layer 2 is a Ground plane. Furthermore, there must have only one ground plane under high-speed signals in order to avoid the high-speed signals to cross another ground plane.

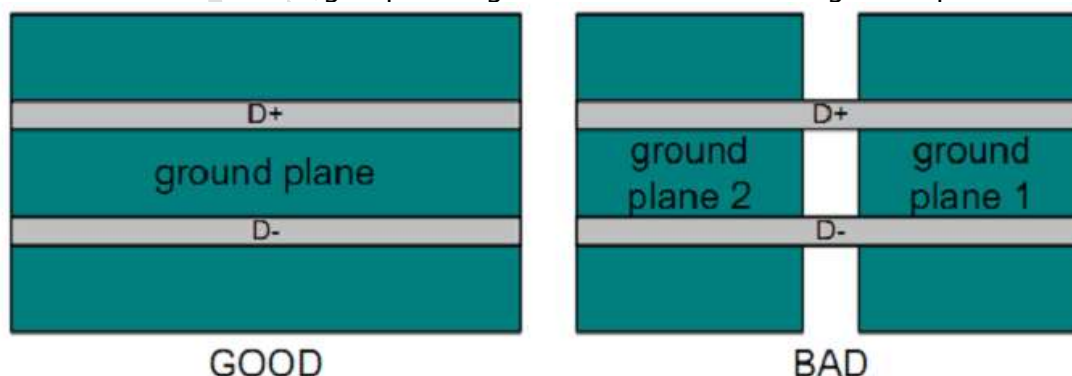

Fig.3-3 RK3126C USB OTG/Host2.0 ground plane guide.

- Component Placement

It is very important to not create stubs on the high-speed lines, to avoid that, the placement of component should be the closed as possible from D+ and D- lines, like shown in the following figure.

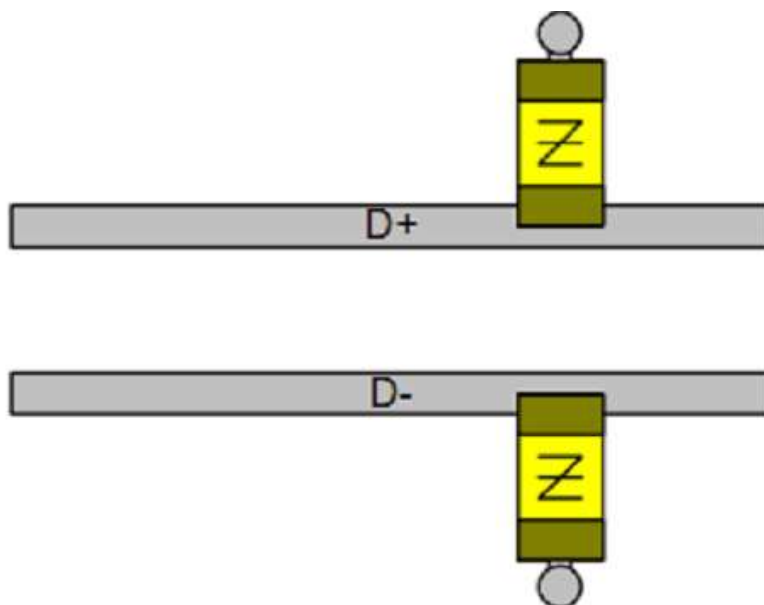

Fig.3-4 RK3126C USB OTG/Host2.0 component placement.

3.12.4 Reference design for Audio Codec connection

In RK3126C, the following diagram shows external PCB reference design for Audio Codec.

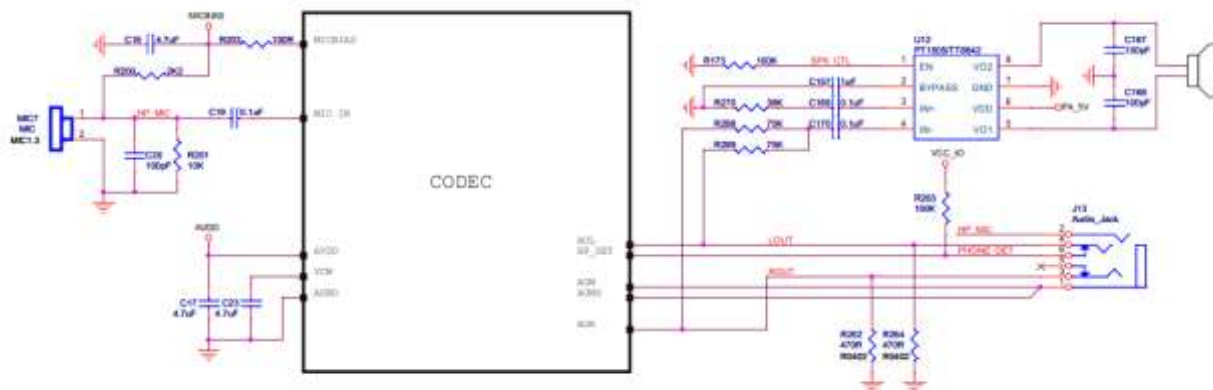

Fig.3-5 RK3126C Audio Codec interface reference connection

As above diagram shows, the MIC_IN connected with a MIC through a 0.1µF CAP. The R203 and C18 are formed a filter for the MIC. The MIC_BIAS is used for bias the MIC through a resistor. The resistor value should be changed according the MIC type. The AVDD should be supplied by 3.3V. The CAP connected with AVDD should be placed as close as possible

The VCM is connected with GND through a 4.7µF CAP. The CAP should be placed as close as possible. The AOUT and AOR could be connected with a speaker or an earphone.

3.12.5 RK3126C Power on reset descriptions

NPOR is hardware reset signal from out-chip, which is filtered glitch to obtain signal sysrstn. To make PLLs work normally, the PLL reset signal (pllrstn) must maintain high for more than 1µs, and PLLs start to lock when pllrstndeassert, and the PLL max lock time is 1500 PLL REFCLK cycles. And then the system will wait about 138µs, and then deactivate reset signal chiprstn. The signal chiprstn is used to generate output clocks in CRU. After CRU start output clocks, the system waits again for 512cycles (21.3µs) to deactivate signal rstn_pre, which is used to generate power on reset of all IP.

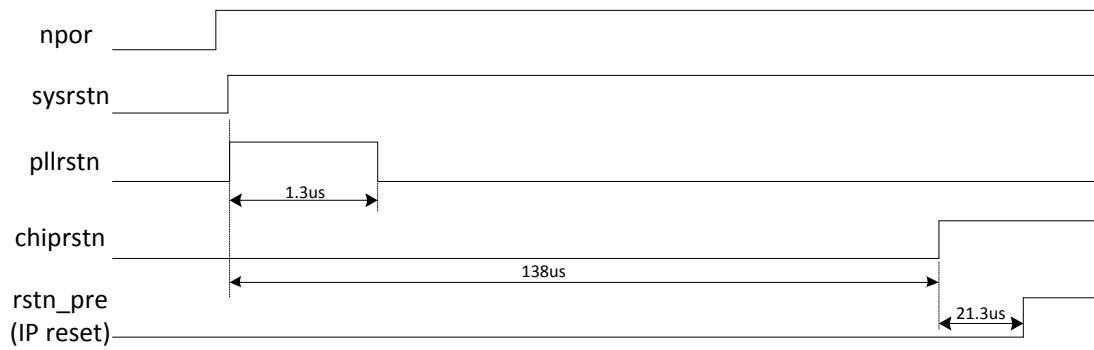

Fig.3-6 RK3126C reset signals sequence

Chapter 4 Thermal Management

4.1 Overview

For reliability and operability concerns, the absolute maximum junction temperature of RK3126C has to be below 125°C.

4.2 Package Thermal Characteristics

Table 4-1 provides the thermal resistance characteristics for the package used on RK3126C. The resulting simulation data for reference only, please prevail in kind test.

Table 4-1 RK3126C Thermal Resistance Characteristics

Package (LQFP)	Power(W)	θ_{JA} (°C/W)	θ_{JB} (°C/W)	θ_{JC} (°C/W)
RK3126C	4.5	15.3	6.70	6.8

Note: The testing PCB is based on 4 layers, 90x90 mm, 1 mm Thickness, ambient temperature is 25 °C,