

Rockchip RK805 Datasheet

**Revision 1.1
Sep.2016**

Revision History

Date	Revision	Description
2016-9-21	1.1	Update
2016-9-9	1.0	Initial release

Table of Content

Table of Content	3
Figure Index	4
Table Index 5	
Warranty Disclaimer	6
Chapter 1 Introduction	7
1.1 Overview	7
1.2 Feature	7
1.3 Typical Application Diagrams	8
Chapter 2 Package information	9
2.1 Ordering information	9
2.2 Top Marking	9
2.3 Dimension	10
2.4 Pin Assignment	11
2.5 Pinout Number Order	11
Chapter 3 Electrical Characteristics	13
3.1 Absolute Maximum Ratings	13
3.2 Recommended Operating Conditions	13
3.3 DC Characteristics	13
Chapter 4 Function Description	15
4.1 State Machine Description	15
4.2 Device Power on Enable Conditions	15
4.3 Device Power on Disable Conditions	15
4.4 Device Sleep Enable Conditions	15
4.5 Power Sequence	15
4.6 Boot Timing Characteristic	17
Chapter 5 Register Description	19
5.1 Register Summary	19
5.2 Register Description	20
Chapter 6 Thermal Management	39
6.1 Overview	39
6.2 Package Thermal Characteristics	39

Figure Index

Fig. 2-1 RK805 One Battery Cell Application	8
Fig. 2-1 QFN32 4mm X 4mm (Pitch is 0.4mm)	10
Fig. 2-2 Pin Assignment.....	11
Fig. 4-1 State Machine	15
Fig. 4-1 Power On/Off Timing, BOOT=0 (RK805-0)	16
Fig. 4-1 Power On/Off Timing, BOOT=1 (RK805-1)	17
Fig. 4-1 Power On/Off Timing, BOOT=1 (RK805-2)	17

Table Index

Table 4-1 Power Start Up Sequence	16
Table 4-2 Boot Timing Characteristics	18
Table 6-1 Thermal Resistance Characteristics	39

Warranty Disclaimer

Rockchip Electronics Co., Ltd makes no warranty, representation or guarantee (expressed, implied, statutory, or otherwise) by or with respect to anything in this document, and shall not be liable for any implied warranties of non-infringement, merchantability or fitness for a particular purpose or for any indirect, special or consequential damages.

Information furnished is believed to be accurate and reliable. However, Rockchip Electronics Co., Ltd assumes no responsibility for the consequences of use of such information or for any infringement of patents or other rights of third parties that may result from its use.

Rockchip Electronics Co., Ltd's products are not designed, intended, or authorized for using as components in systems intended for surgical implant into the body, or other applications intended to support or sustain life, or for any other application in which the failure of the Rockchip Electronics Co., Ltd's product could create a situation where personal injury or death may occur, should buyer purchase or use Rockchip Electronics Co., Ltd's products for any such unintended or unauthorized application, buyers shall indemnify and hold Rockchip Electronics Co., Ltd and its officers, employees, subsidiaries, affiliates, and distributors harmless against all claims, costs, damages, expenses, and reasonable attorney fees arising out of, either directly or indirectly, any claim of personal injury or death that may be associated with such unintended or unauthorized use, even if such claim alleges that Rockchip Electronics Co., Ltd was negligent regarding the design or manufacture of the part.

Copyright and Patent Right

Information in this document is provided solely to enable system and software implementers to use Rockchip Electronics Co., Ltd 's products. There are no expressed or implied copyright licenses granted hereunder to design or fabricate any integrated circuits or integrated circuits based on the information in this document.

Rockchip Electronics Co., Ltd does not convey any license under its patent rights nor the rights of others.

All copyright and patent rights referenced in this document belong to their respective owners and shall be subject to corresponding copyright and patent licensing requirements.

Trademarks

Rockchip and Rockchip™ logo and the name of Rockchip Electronics Co., Ltd's products are trademarks of Rockchip Electronics Co., Ltd. and are exclusively owned by Rockchip Electronics Co., Ltd. References to other companies and their products use trademarks owned by the respective companies and are for reference purpose only.

Confidentiality

The information contained herein (including any attachments) is confidential. The recipient hereby acknowledges the confidentiality of this document, and except for the specific purpose, this document shall not be disclosed to any third party.

Reverse engineering or disassembly is prohibited.

ROCKCHIP ELECTRONICS CO.,LTD. RESERVES THE RIGHT TO MAKE CHANGES IN ITS PRODUCTS OR PRODUCT SPECIFICATIONS WITH THE INTENT TO IMPROVE FUNCTION OR DESIGN AT ANY TIME AND WITHOUT NOTICE AND IS NOT REQUIRED TO UNDATE THIS DOCUMENTATION TO REFLECT SUCH CHANGES.

Copyright © 2016 Rockchip Electronics Co., Ltd.

All rights reserved. No part of this publication may be reproduced, stored in a retrieval system, or transmitted in any form or by any means, electric or mechanical, by photocopying, recording, or otherwise, without the prior written consent of Rockchip Electronics Co., Ltd.

Chapter 1 Introduction

1.1 Overview

The RK805 is a complete power supply solution for Portable systems. The highly integrated device includes four buck DC-DC converters, three high performance Idos, I²C interface, programmable power sequencing and an RTC.

The RK805 improves performance, reduces component count and size, and therefore provides lower cost solution compared to conventional portable designs. The ultra fast 2MHz current mode DC/DC architecture optimizes the transient performance and is compatible with tiny low cost ceramic inductors and capacitors. All DC/DC channels include integrated MOSFETS. Internal soft-start and compensation circuits minimize external components count. Most outputs can be programmed through the I²C interface

The RK805 integrates internal RC oscillator for low cost application which without RTC function.

1.2 Feature

- Input voltage range: 2.7V to 5.5V
- 2MHz Switching Frequency for bucks
- Current mode architecture for best transient performance
- Internal compensation and soft start
- I²C Programmable output levels and power sequencing
- High efficiency architecture
- Integrated Vout Discharge Circuit for BUCK and LDO
- Power:
 - CH1: Synchronous Buck regulator, 2.5A max
 - CH2: Synchronous Buck regulator, 2.5A max
 - CH3: Synchronous Buck regulator, 1.5A max
 - CH4: Synchronous Buck regulator, 1.5A max
 - CH5,CH6: Linear regulators, 300mA max
 - CH7: Low noise and high PSRR linear regulator,100mA max
- Auxiliary: Flexible Power Sequence control
- Package: 4mmx4mm QFN32 (pitch 0.4mm)

1.3 Typical Application Diagrams

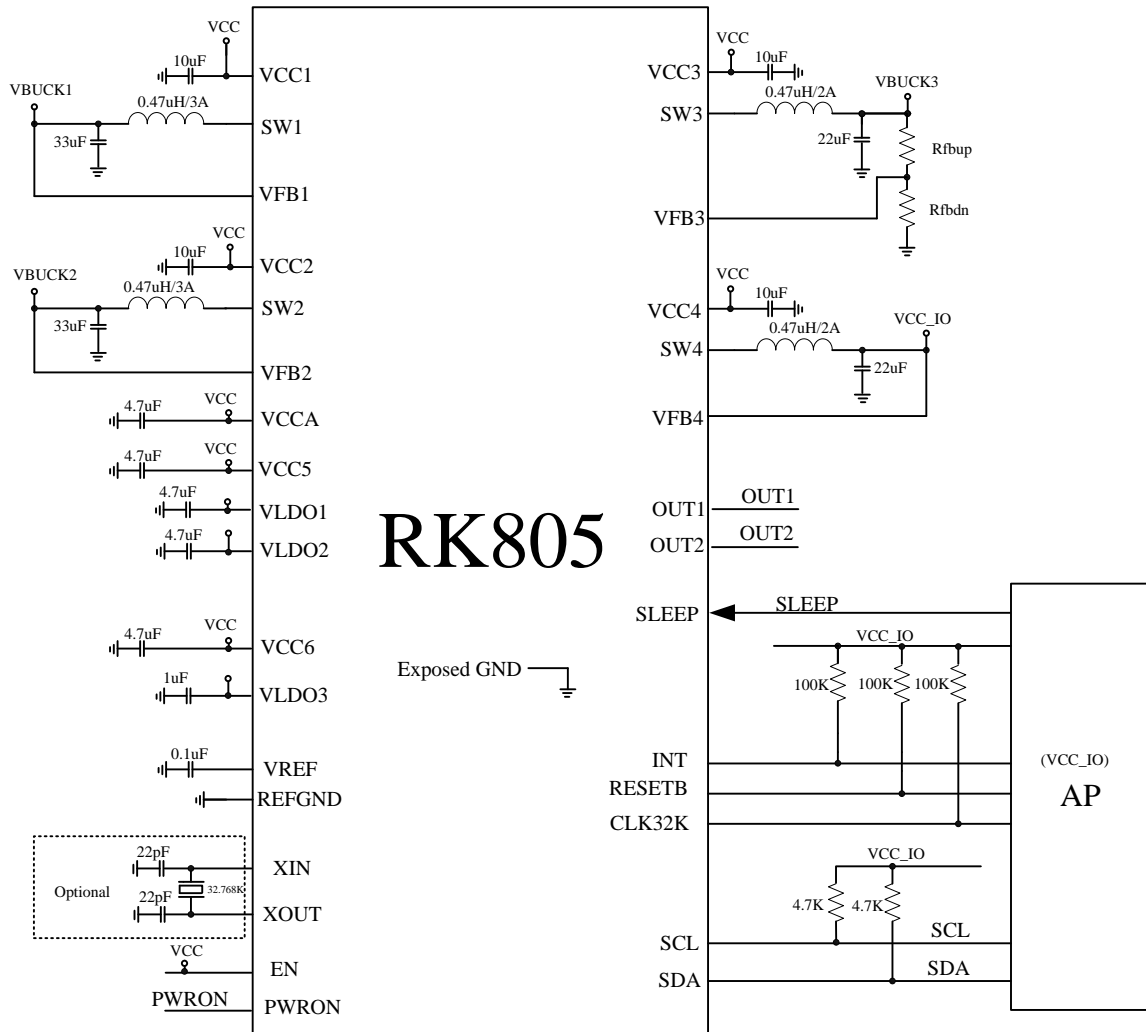

Fig. 1-1 RK805 One Battery Cell Application

Chapter 2 Package information

2.1 Ordering information

Orderable Device	RoHS status	Package	Package Qty	Device special feature
RK805-1	RoHS pass	QFN32(4X4)	4900ea/inner box* 6 inner boxes/outer box	For RK3228 application
RK805-2	RoHS pass	QFN32(4X4)	4900ea/inner box* 6 inner boxes/outer box	For RK1108 application

2.2 Top Marking

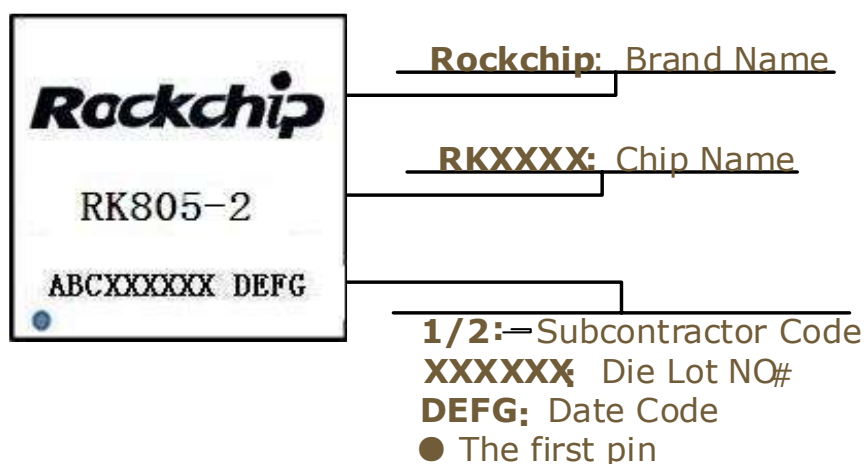
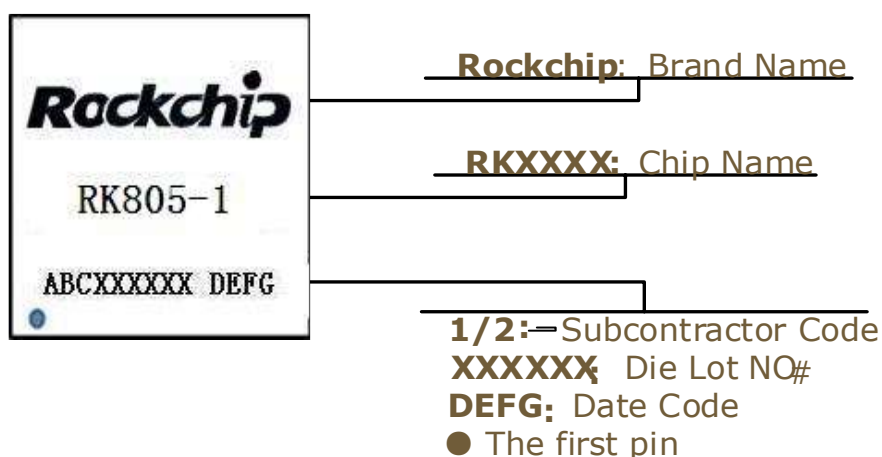

2.3 Dimension

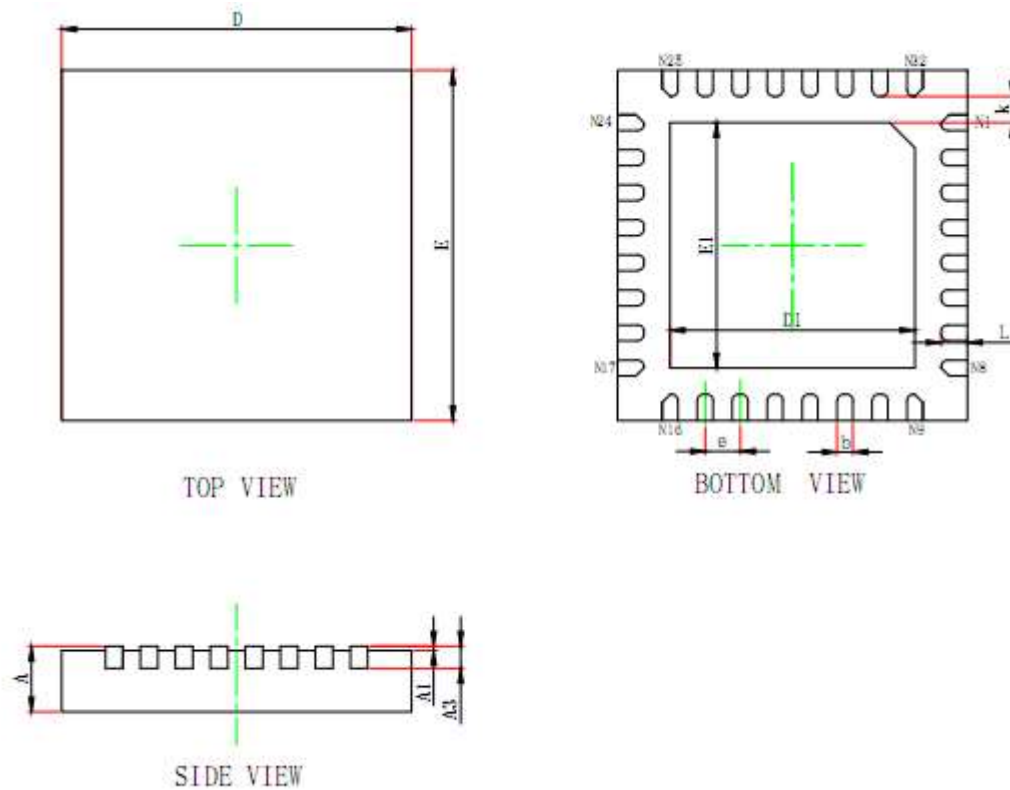

Fig. 2-1 QFN32 4mm X 4mm (Pitch is 0.4mm)

DESCRIPTION	SYMBOL	MILLIMETER		
		MIN	NOM	MAX
TOTAL THICKNESS	A	0.70/0.80		0.80/0.90
STAND OFF	A1	0	0.035	0.05
MATERIAL THICKNESS	A3	-	0.203 _{REF}	-
PACKAGE SIZE	D	3.924		4.076
	E	3.924		4.076
EP SIZE	D1	2.700		2.900
	E1	2.700		2.900
LEAD LENGTH	L	0.224		0.376
LEAD PITCH	e	0.400 _{TYP}		
LEAD WIDTH	b	0.150		0.250
LEAD TO EXPOSED	k	0.200 _{MIN}		

Note:

- Coplanarity applies to leads, corner leads and die attach pad.
- Dimension b applies to metalized terminal and is measured between 0.15mm and 0.30mm from the terminal tip. If the terminal has the optional radius on the other end of the terminal, the dimension b should not be measure in that radius area.
- 0.15mm of dimension b is recommended in PCB layout.

2.4 Pin Assignment

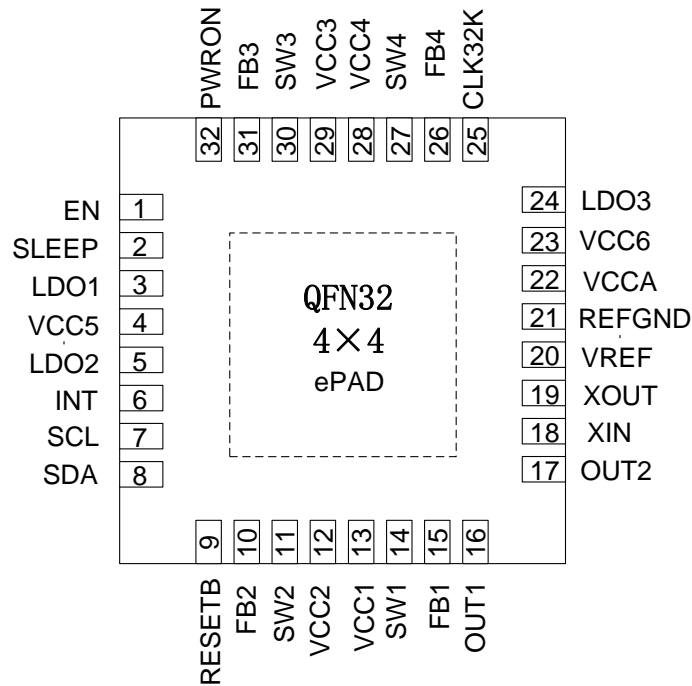

Fig. 2-2 Pin Assignment

2.5 Pinout Number Order

PIN NO	PIN NAME	PIN DESCRIPTION
1	EN	Power on or power off enable pin, active high, internal 800k resistor pull low to ground
2	SLEEP	Sleep mode control input
3	LDO1	LDO1 output
4	VCC5	Power supply of LDO1/2
5	LDO2	LDO2 output
6	INT	Interrupt request pin, open drain
7	SCL	I2C clock input
8	SDA	I2C data input and output
9	RESETB	Reset pin after power on, active low
10	FB2	Output feedback voltage of buck2
11	SW2	Switching node of buck2
12	VCC2	Power supply of buck2
13	VCC1	Power supply of buck1
14	SW1	Switching node of buck1
15	FB1	Output feedback voltage of buck1
16	OUT1	General digital output pin 1, CMOS level output, high level is VFB4
17	OUT2	General digital output pin 2, CMOS level output, high level is VFB4
18	XIN	32.768KHz crystal oscillator input
19	XOUT	32.768KHz crystal oscillator output
20	VREF	Internal reference voltage
21	REFGND	Reference ground
22	VCCA	Power supply of controller
23	VCC6	Power supply of LDO3

PIN NO	PIN NAME	PIN DESCRIPTION
24	LDO3	LDO3 output
25	CLK32K	32.768KHz clock output, open drain
26	FB4	Output feedback voltage of buck4
27	SW4	Switching node of buck4
28	VCC4	Power supply of buck4
29	VCC3	Power supply of buck3
30	SW3	Switching node of buck3
31	FB3	Output feedback voltage of buck3
32	PWRON	Power on key input, active low, internal 17k resistor pull high to VCCA
Exposed pad	Exposed ground	Ground

Chapter 3 Electrical Characteristics

3.1 Absolute Maximum Ratings

Parameter	Min	Max	Units
Voltage range on pins VCCx, SWx, FBx	-0.3	6.5	V
Voltage range on pins LDOx, VREF	-0.3	6.5	V
Voltage range on pin CLK32K, SLEEP	-0.3	6.5	V
Voltage range on pins XIN,XOUT, EN, PWRON	-0.3	VCCx_MAX+0.3	
Voltage range on pins RESETB, INT, SDA, SCL,OUT1,OUT2	-0.3	4	V
Storage temperature range, TS	-40	150	°C
Operating temperature range, TJ	-40	125	°C
Maximum Soldering Temperature, T _{SOLDER}		300	°C

Note 1. Exposure to the conditions exceeded absolute maximum ratings may cause the permanent damages and affect the reliability and safety of both device and systems using the device. The functional operations cannot be guaranteed beyond specified values in the recommended conditions.

3.2 Recommended Operating Conditions

Parameter	Min	TYP	Max	Units
Voltage range on pins VCCx	2.7	5	5.5	V
Voltage range on other pins			5.5	V
Power Dissipation			2.7	W

3.3 DC Characteristics

T_J=25°C; V_{VCCA}=VCCx=5V, unless otherwise specified.

Parameter	Symbol	Condition	Min.	Typ.	Max.	Unit
VCCA Input (VCCA is the power supply of controller)						
VCCA Operating Range	V _{VCCA}		2.8	5	5.5	V
VCCA over voltage protect	V _{VCCA_ov}			6		V
VCCA under voltage protect	V _{VCCA_uv}	Step=0.1V, from 2.7V to 3.4V programmable		2.7		V
VCCA low voltage alarm	V _{VCCA_lv}	Step=0.1V, from 2.8V to 3.5V programmable		3.3		V
VCCA OK voltage threshold	V _{VCCA_ok}	2.8V/3.0V/3.4V/3.6V OTP programmable		3.0		V
CH1: Buck 1						
Input supply voltage range	V _{CC1}		2.7		5.5	V
Voltage Adjustable Range, 6bit	V _{FB1}	0.7125V~1.45V (Step=12.5mV)/1.8V/2.0V/2.2V/2.3V	0.7125		2.300	V
Rated output current	I _{MAX1}			2.5		A
Output voltage transition rate	dV/dt	BUCK1_RATE=00		3		mV/uS
		BUCK1_RATE=01		6		
		BUCK1_RATE=10		12.5		

Parameter	Symbol	Condition	Min.	Typ.	Max.	Unit
		BUCK1_RATE=11		25		
CH1: Buck 2						
Input supply voltage range	V _{CC2}		2.7		5.5	V
Voltage Adjustable Range, 6bit	V _{FB2}	0.7125V~1.45V (Step=12.5mV)/1.8V/2.0V/2.2V/2.3V	0.7125		2.300	V
Rated output current	I _{MAX2}			2.5		A
Output voltage transition rate	dV/dt	BUCK1_RATE=00		3		mV/uS
		BUCK1_RATE=01		6		
		BUCK1_RATE=10		12.5		
		BUCK1_RATE=11		25		
CH1: Buck 3						
Input supply voltage range	V _{CC3}		2.7		5.5	V
Feedback Voltage	V _{FB3}		0.784	0.800	0.816	V
Rated output current	I _{MAX3}			1.5		A
V _{BUCK3OUT} = V _{FB3} * (1+R _f buP/R _f bdn); please refer to the typical application						
CH1: Buck 4						
Input supply voltage range	V _{CC4}		2.7		5.5	V
Voltage Adjustable Range, 5bit	V _{FB4}	Step=100mV	0.8		3.5	V
Rated output current	I _{MAX4}			1.5		A
CH5 : LDO1						
Input supply voltage range	V _{CC5}		2.0		5.5	V
V _{OUT} Output Voltage Adjustable Range, 5bit	V _{LDO1}	Step=100mV	0.8		3.4	V
Rated output current	I _{MAX5}	V _{CC5} =5V		300		mA
Power supply reject ratio (f=1kHz)	PSRR1	V _{CC5} =5V, V _{LDO1} =1V		50		dB
Drop-out voltage @ 300mA	V _{drop-out1}	V _{LDO1} =3.4V,		200		mV
CH6 : LDO2						
Input supply voltage range	V _{CC5}		2.0		5.5	V
V _{OUT} Output Voltage Adjustable Range, 5bit	V _{LDO2}	Step=100mV	0.8		3.4	V
Rated output current	I _{MAX6}	V _{CC5} =5V		300		mA
Power supply reject ratio (f=1kHz)	PSRR2	V _{CC5} =5V, V _{LDO2} =1.8V		50		dB
Drop-out voltage @ 300mA	V _{drop-out2}	V _{LDO2} =3.4V,		200		mV
CH7 : LDO3						
Input supply voltage range	V _{CC6}		2.0		5.5	V
V _{OUT} Output Voltage Adjustable Range, 5bit	V _{LDO3}	Step=100mV	0.8		3.4	V
Rated output current	I _{MAX7}	V _{CCA} =5V		100		mA
Power supply reject ratio (f=1kHz)	PSRR3	V _{CCA} =5V, V _{LDO3} =1.0V		70		dB
Drop-out voltage @ 100mA	V _{drop-out3}	V _{LDO3} =3.4V,		200		mV
I2C Interface(7 bits I2C slave address:0011000)						
SCL clock frequency	f _{SCL}				1	MHz
RTC						
RTC operation voltage			2.5		5.5	V
CLK32K Jitter				100		nS
CLK32K duty			40		60	%

Chapter 4 Function Description

4.1 State Machine Description

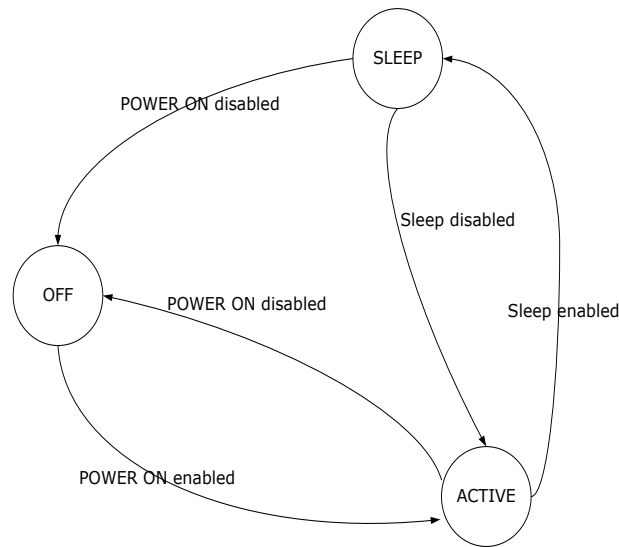

Fig. 4-1 State Machine

4.2 Device Power on Enable Conditions

- If none of the device power-on disable conditions is met, the following conditions are available to turn on the device:
 - EN signal rise edge.
 - EN signal is high level, and PWRON signal keep low level at least 500mS while the device is off.
 - EN signal is high level, and RTC alarm interrupt flag active while the device is off.

4.3 Device Power on Disable Conditions

- EN signal keep low level.
- PWRON signal low level during more than the long-press delay: TDPWRONLP.
- Die temperature has reached the thermal shutdown threshold.
- VCCA down below UVLO threshold.
- VCCA down below VBLO threshold, and Reg21<4>=0.
- VCCA higher than OVP threshold.
- SLEPP signal active, and Reg50<3:2>=1X
- DEV_OFF control bit set to 1.

4.4 Device Sleep Enable Conditions

- SLEEP signal high level and Reg50<1>=1, and Reg50<3:2>=01.
- SLEEP signal low level and Reg50<1>=0, and Reg50<3:2>=01.
- Reg4b<1>=1.

4.5 Power Sequence

AP			Null		RK3228		RK1108	
BOOT(OTP)			0		1			
			RK805-0		RK805-1		RK805-2	
	Output voltage range	Max output current	Default voltage	Power sequence	Default voltage	Power sequence	Default voltage	Power sequence
BUCK1	0.7125V-1.45V(step 12.5mV) /1.8V/2V/2.2V/2.3V	2.5A	1.0V	2	1.1V	2	1.0V	2
BUCK2	0.7125V-1.45V(step 12.5mV) /1.8V/2V/2.2V/2.3V	2.5A	1.0V	2	1.1V	2	1.0V	X
BUCK3	setting by external resistors	1.5A	X	3	X	3	X	3
BUCK4	0.8V-3.5V(step=0.1V)	1.5A	3.3V	5	3.3V	5	3.3V	5
LDO1	0.8V-3.4V(step=0.1V)	300mA	1.0V	1	1.8V	4	1.0V	1
LDO2	0.8V-3.4V(step=0.1V)	300mA	1.8V	4	1.8V	4	1.8V	4
LDO3	0.8V-3.4V(step=0.1V)	100mA	1.0V	1	1.0V	1	1.0V	1
RESETB			X	8	X	10	X	10

Table 4-1 Power Start Up Sequence

X: The buck3 voltage is decided by external resistors. The RESETB is open drain output.

4.5.1 BOOT = 0 (RK805-0)

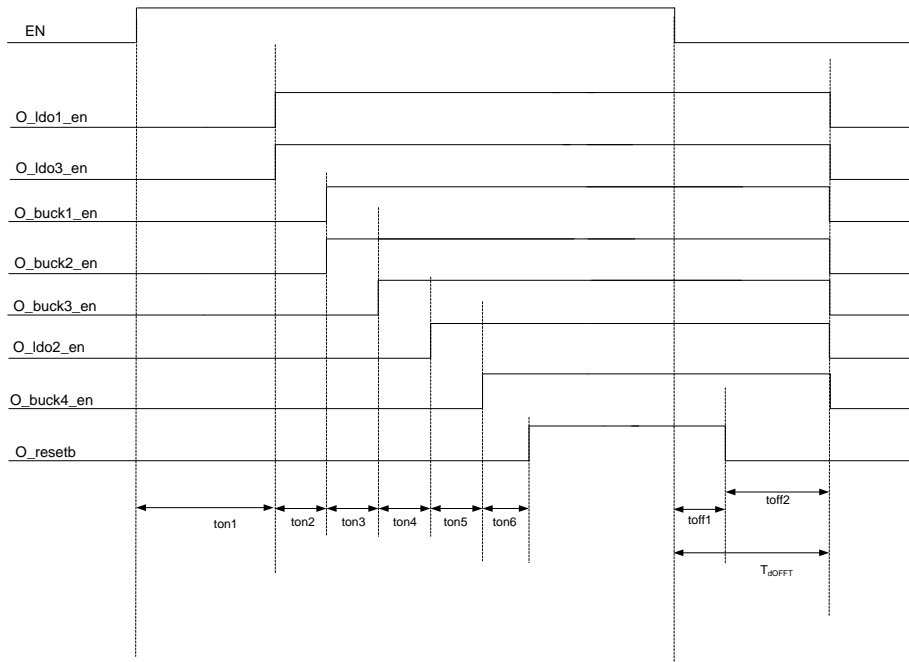

Fig. 4-2 Power On/Off Timing, BOOT=0 (RK805-0)

4.5.2 BOOT = 1 (RK805-1)

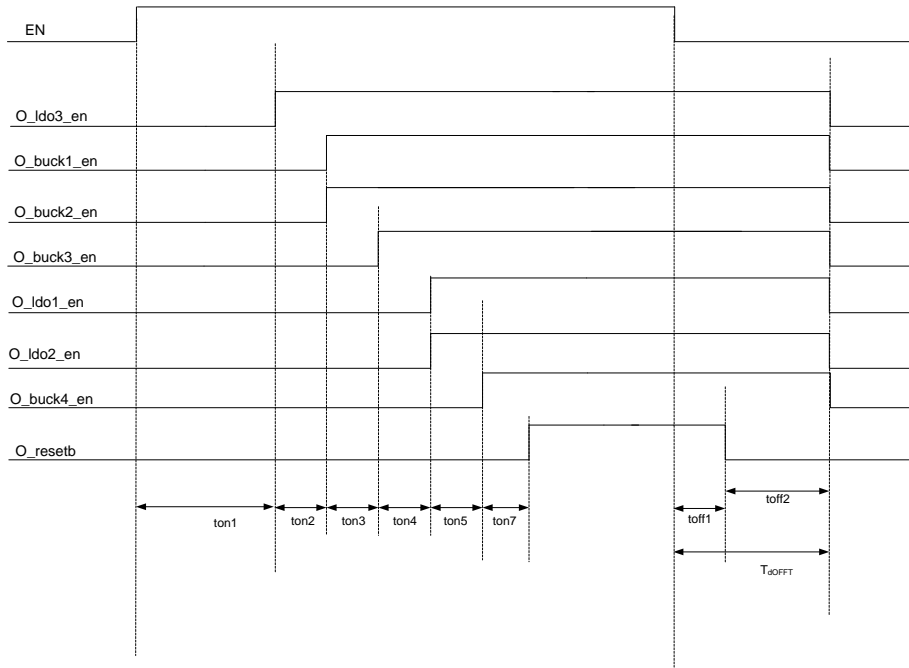

Fig. 4-3 Power On/Off Timing, BOOT=1 (RK805-1)

4.5.3 BOOT = 1 (RK805-2)

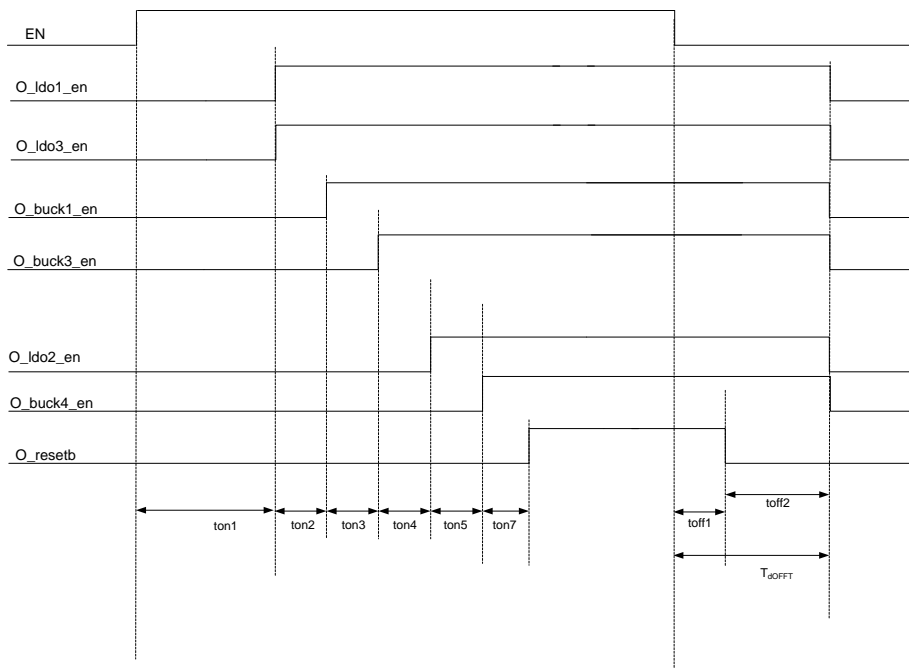

Fig. 4-4 Power On/Off Timing, BOOT=1 (RK805-2)

4.6 Boot Timing Characteristic

PARAMETERS	DESCRIPTION	MIN	TYP	MAX	UNIT
Ton1	Reference and system ready 1st channel enable delay		6		ms
Ton2	1st channel enable delay to 2nd channel enable delay		2		ms
Ton3	2nd channel enable to 3rd channel enable delay		2		ms
Ton4	3rd channel enable to 4th channel enable delay		2		ms
Ton5	4th channel enable to 5th channel enable delay		2		ms
Ton6	5th channel enable to RESET enable delay @ RK805-0		6		ms

PARAMETERS	DESCRIPTION	MIN	TYP	MAX	UNIT
Ton7	5th channel enable to RESET enable delay @ RK805-1/2		10		ms
toff1	power disable to RESETB falling delay		$1 \times t_{CK32K}$		us
Toff2	RESETB falling delay to supplies disable delay		2		ms
Ton1	Reference and system ready 1st channel enable delay		6		ms
Ton2	1st channel enable delay to 2nd channel enable delay		2		ms

Table 4-2 Boot Timing Characteristics

Chapter 5 Register Description

5.1 Register Summary

HEX ADDRESS	ACTION/ DESCRIPTION	R/W	DEFAULT/ RESET
RTC Register			
00	SECONDS_REG	RW	0x00
01	MINUTES_REG	RW	0x50
02	HOURS_REG	RW	0x08
03	DAYS_REG	RW	0x21
04	MONTHS_REG	RW	0x01
05	YEARS_REG	RW	0x16
06	WEEKS_REG	RW	0x04
08	ALARM_SECONDS_REG	RW	0x00
09	ALARM_MINUTES_REG	RW	0x00
0A	ALARM_HOURS_REG	RW	0x00
0B	ALARM_DAYS_REG	RW	0x01
0C	ALARM_MONTHS_REG	RW	0x01
0D	ALARM_YEARS_REG	RW	0x00
10	RTC_CTRL_REG	RW	0x00
11	RTC_STATUS_REG	RW	0x82
12	RTC_INT_REG	RW	0x00
13	RTC_COMP_LSB_REG	RW	0x00
14	RTC_COMP_MSB_REG	RW	0x00
20	CLK32KOUT_REG	RW	0x01
Version Register			
17	CHIP_NAME_REG	RO	0x80
18	CHIP_VER_REG	RO	0x50
19	OTP_VER_REG	RO	0000/otp<3:0>
PMU Control Register			
21	VB_MON_REG	RW	0x14
22	VB_UV_REG/THERMAL_REG	RW	0x00
47	PWRON_LP_INT_TIME_REG	RW	0x20
48	PWRON_DB_REG	RW	0x40
4B	DEV_CTRL_REG	RW	0x00
4C	INT_STS_REG	RW	0x00
4D	INT_STS_MSK_REG	RW	0x00
50	IO_POL_REG	RW	0x02
52	OUT_REG	RW	0x00
AE	ON_SOURCE_REG	RO	0x00
AF	OFF_SOURCE_REG	RO	0x00
Power Chanel Enable Register			
23	DCDC_EN_REG	RW	Boot0:0x0F Boot1:0000/otp<3:0>
25	SLP_DCDC_EN_REG	RW	Boot0:0x0F Boot1:0000/otp<3:0>

HEX ADDRESS	ACTION/ DESCRIPTION	R/W	DEFAULT/ RESET
26	SLP_LDO_EN_REG	RW	Boot0:0x07 Boot1:00000/otp<2:0>
27	LDO_EN_REG	RW	Boot0:0x07 Boot1:00000/otp<2:0>
2A	BUCK_LDO_SLP_LP_REG	RW	Boot0:0x07 Boot1:00000/otp<0>/0 0
BUCK and LDO Configure Register			
2E	BUCK1_CONFIG_REG	RW	0x7A
2F	BUCK1_ON_VSEL_REG	RW	Boot0:0x17 Boot1:00/otp<5:0>
30	BUCK1_SLP_VSEL_REG	RW	Boot0:0x17 Boot1:00/otp<5:0>
32	BUCK2_CONFIG_REG	RW	0x7A
33	BUCK2_ON_VSEL_REG	RW	Boot0:0x17 Boot1:00/otp<5:0>
34	BUCK2_SLP_VSEL_REG	RW	Boot0:0x17 Boot1:00/otp<5:0>
36	BUCK3_CONFIG_REG	RW	0x2A
37	BUCK4_CONFIG_REG	RW	0x2A
38	BUCK4_ON_VSEL_REG	RW	Boot0:0x19 Boot1:000/otp<4:0>
39	BUCK4_SLP_VSEL_REG	RW	Boot0:0x19 Boot1:000/otp<4:0>
3B	LDO1_ON_VSEL_REG	RW	Boot0:0x22 Boot1:001/otp<4:0>
3C	LDO1_SLP_VSEL_REG	RW	Boot0:0x02 Boot1:000/otp<4:0>
3D	LDO2_ON_VSEL_REG	RW	Boot0:0x2A Boot1:001/otp<4:0>
3E	LDO2_SLP_VSEL_REG	RW	Boot0:0x0A Boot1:000/otp<4:0>
3F	LDO3_ON_VSEL_REG	RW	Boot0:0x22 Boot1:001/otp<4:0>
40	LDO3_SLP_VSEL_REG	RW	Boot0:0x02 Boot1:000/otp<4:0>

NOTE: Address 51h through 97h are for OTP registers. Customer’s accessibility to those addresses is not allowed.

5.2 Register Description

5.2.1 RTC Registers

- **SECONDS_REG : RTC SECOND Register**

Address: 00H				Type: RW				
Bit	Bit7	Bit6	Bit5	Bit4	Bit3	Bit2	Bit1	Bit0
SYMBOL	RESV	SEC1			SEC0			
Default	0	0	0	0	0	0	0	0

Description

- Bit 7 Reserved
- Bit 6-4 Set the second digit of the RTC seconds (0-5)
- Bit 3-0 Set the first digit of the RTC seconds (0-9)
- Note BCD coding from 00 - 59

● **MINUTES_REG : RTC MINUTE Register**

Address: 01H				Type: RW				
Bit	Bit7	Bit6	Bit5	Bit4	Bit3	Bit2	Bit1	Bit0
SYMBOL	RESV	MIN1		MIN0				
Default	0	1	0	1	0	0	0	0

Description

- Bit 7 Reserved
- Bit 6-4 Set the second digit of the RTC minutes
- Bit 3-0 Set the first digit of the RTC minutes
- Note BCD coding from 00 - 59

● **HOURS_REG : RTC HOUR Register**

Address: 02H				Type: RW				
Bit	Bit7	Bit6	Bit5	Bit4	Bit3	Bit2	Bit1	Bit0
SYMBOL	PM/AM	RESV	HOUR1		HOUR0			
Default	0	0	0	0	1	0	0	0

Description

- Bit 7 Set PM or AM: Only used in PM-AM mode, 1: PM. 0:AM.
- Bit 6 Reserved
- Bit 5-4 Set the second digit of the RTC hours
- Bit 3-0 Set the first digit of the RTC hours
- Note HOUR1/0 BCD coding from 0-11/23

● **DAYS_REG : RTC DAY Register**

Address: 03H				Type: RW				
Bit	Bit7	Bit6	Bit5	Bit4	Bit3	Bit2	Bit1	Bit0
SYMBOL	RESV	RESV	DAY1		DAY0			
Default	0	0	1	0	0	0	0	1

Description

- Bit 7-6 Reserved
- Bit 5-4 Set the second digit of the RTC days
- Bit 3-0 Set the first digit of the RTC days
- Note BCD coding from 01 - 28/29/30/31

● **MONTHS_REG : RTC MONTH Register**

Address: 04H				Type: RW				
Bit	Bit7	Bit6	Bit5	Bit4	Bit3	Bit2	Bit1	Bit0
SYMBOL	RESV	RESV	RESV	MONTH 1	MONTH0			
Default	0	0	0	0	0	0	0	1

Description

Bit 7-5 Reserved
 Bit 4 Set the second digit of the RTC months
 Bit 3-0 Set the first digit of the RTC months
 Note BCD coding from 01 - 12

● **YEARS_REG : RTC YEAR Register**

Address: 05H					Type: RW			
Bit	Bit7	Bit6	Bit5	Bit4	Bit3	Bit2	Bit1	Bit0
SYMBOL	YEAR1			YEAR0				
Default	0	0	0	1	0	1	1	0

Description

Bit 7-5 Set the second digit of the RTC years
 Bit 3-0 Set the first digit of the RTC years
 Note BCD coding from 00 - 99

● **WEEKS_REG : RTC WEEK Register**

Address: 06H					Type: RW			
Bit	Bit7	Bit6	Bit5	Bit4	Bit3	Bit2	Bit1	Bit0
SYMBOL	RESV	RESV	RESV	RESV	RESV	WEEK		
Default	0	0	0	0	0	1	0	0

Description

Bit 7-3 Reserved
 Bit 2-0 Set the RTC weeks
 Note BCD coding from 1 - 7

● **ALARM_SECONDS_REG : RTC ALARM SECOND Register**

Address: 08H					Type: RW			
Bit	Bit7	Bit6	Bit5	Bit4	Bit3	Bit2	Bit1	Bit0
SYMBOL	RESV	ALARM_SEC1			ALARM_SEC0			
Default	0	0	0	0	0	0	0	0

Description

Bit 7 Reserved
 Bit 6-4 Set the second digit of the RTC alarm seconds
 Bit 3-0 Set the first digit of the RTC alarm seconds
 Note BCD coding from 00 - 59

● **ALARM_MINUTES_REG : RTC ALARM MINUTE Register**

Address: 09H					Type: RW			
Bit	Bit7	Bit6	Bit5	Bit4	Bit3	Bit2	Bit1	Bit0
SYMBOL	RESV	ALARM_MIN1			ALARM_MIN0			
Default	0	0	0	0	0	0	0	0

Description

- Bit 7 Reserved
- Bit 6-4 Set the second digit of the RTC alarm minutes
- Bit 3-0 Set the first digit of the RTC alarm minutes
- Note BCD coding from 00 - 59

● **ALARM_HOURS_REG : RTC ALARM HOUR Register**

Address: 0AH				Type: RW				
Bit	Bit7	Bit6	Bit5	Bit4	Bit3	Bit2	Bit1	Bit0
SYMBOL	ALARM_PM_AM	RESV	ALARM_HOUR1	ALARM_HOU0				
Default	0	0	0	0	0	0	0	0

Description

- Bit 7 Set PM or AM: Only used in PM-AM mode, 1: PM. 0:AM.
- Bit 6 Reserved
- Bit 5-4 Set the second digit of the RTC alarm hours
- Bit 3-0 Set the first digit of the RTC alarm hours
- Note HOUR1/0 BCD coding from 0-11/23

● **ALARM_DAYS_REG : RTC ALARM DAY Register**

Address: 0BH				Type: RW				
Bit	Bit7	Bit6	Bit5	Bit4	Bit3	Bit2	Bit1	Bit0
SYMBOL	RESV	RESV	ALARM_DAY1	ALARM_DAY0				
Default	0	0	0	0	0	0	0	1

Description

- Bit 7-6 Reserved
- Bit 5-4 Set the second digit of the RTC alarm days
- Bit 3-0 Set the first digit of the RTC alarm days
- Note BCD coding from 01 - 28/29/30/31

● **ALARM_MONTHS_REG : RTC ALARM MONTH Register**

Address: 0CH				Type: RW				
Bit	Bit7	Bit6	Bit5	Bit4	Bit3	Bit2	Bit1	Bit0
SYMBOL	RESV	RESV	RESV	ALARM_MONTH 1	ALARM_MONTH0			
Default	0	0	0	0	0	0	0	1

Description

- Bit 7-5 Reserved
- Bit 4 Set the second digit of the RTC alarm months
- Bit 3-0 Set the first digit of the RTC alarm months
- Note BCD coding from 01 - 12

● **ALARM_YEARS_REG : RTC ALARM YEAR Register**

Address: 0DH				Type: RW				
Bit	Bit7	Bit6	Bit5	Bit4	Bit3	Bit2	Bit1	Bit0
SYMBOL	ALARM_YEAR1			ALARM_YEAR0				
Default	0	0	0	0	0	0	0	0

Description

Bit 7-4 Set the second digit of the RTC alarm years
 Bit 3-0 Set the first digit of the RTC alarm years
 Note BCD coding from 00 - 99

● **RTC_CTRL_REG : RTC Control Register**

Address: 10H				Type: RW				
Bit	Bit7	Bit6	Bit5	Bit4	Bit3	Bit2	Bit1	Bit0
SYMBOL	RTC_READ SEL	GET_TI ME	SET_32_ COUNTER	TEST_M ODE	AMPM_ MODE	AUTO_ COMP	ROUND_30S (Auto Clr)	STOP_ RTC
Default	0	0	0	0	0	0	0	0

Description

Bit 7 RTC_READSEL: 0: Read access directly to dynamic registers.
 1: Read access to static shadowed registers
 Bit 6 GET_TIME: Rising transition of this register transfers dynamic registers into static shadowed registers.
 Bit 5 SET_32_COUNTER: 1: set the 32-kHz counter with COMP_REG value. It must only be used when the RTC is frozen.
 Bit 4 TEST_MODE: 1: test mode (Auto compensation is enable when the 32kHz counter reaches at its end)
 Bit 3 AMPM_MODE: 0: 24 hours mode.
 1: 12 hours mode (PM-AM mode)
 Bit 2 AUTO_COMP: 0: No auto compensation RW0.
 1: Auto compensation enabled
 Bit 1 ROUND_30S: 1: When 1 is written, the time is rounded to the closest minute in next second. self cleared after rounding
 Bit 0 STOP_RTC: 1: RTC is frozen.
 0: RTC is running.
 RTC_time can only be changed during RTC frozen

● **RTC_STATUS_REG : RTC Status Register**

Address: 11H				Type: RW				
Bit	Bit7	Bit6	Bit5	Bit4	Bit3	Bit2	Bit1	Bit0
SYMBOL	POWER_UP (Write 1 Clr)	ALARM (Write 1 Clr)	EVENT_1D (Write 1 Clr)	EVENT_1H (Write 1 Clr)	EVENT_1M (Write 1 Clr)	EVENT_1S (Write 1 Clr)	RUN (RO)	RESV
Default	1	0	0	0	0	0	1	0

Description

- Bit 7 POWER_UP: POWER_UP is set by a reset, is cleared by writing one in this bit.
- Bit 6 ALARM: Indicates that an alarm interrupt has been generated (bit clear by writing 1) The alarm interrupt keeps its low level, until the micro-controller writes 1 in the ALARM bit of the RTC_STATUS register.The timer interrupt is a low-level pulse (15 μs duration).
- Bit 5 EVENT_1D: One day has occurred
- Bit 4 EVENT_1H: One hour has occurred
- Bit 3 EVENT_1M: One minute has occurred
- Bit 2 EVENT_1S :One secondr has occurred
- Bit 1 RUN: 0, RTC is frozen. 1, RTC is running. This bit shows the real state of the RTC
- Bit 0 RESEVERED

● **RTC_INT_REG : RTC Interrupt Register**

Address: 12H				Type: RW				
Bit	Bit7	Bit6	Bit5	Bit4	Bit3	Bit2	Bit1	Bit0
SYMBOL	RESV	RESV	RESV	INT_SLEEP_MASK_EN	INT_ALARM_EN	INT_TIMER_EN	EVERY	
Default	0	0	0	0	0	0	0	0

Description

- Bit 7-5 RESEVERED
- Bit 4 INT_SLEEP_MASK_EN:
1: Mask periodic interrupt while the device is in SLEEP mode
0: Normal mode, no interrupt masked.
- Bit 3 INT_ALARM_EN: Enable one interrupt when the alarm value is reached
1: Enable
0: Disable
- Bit 2 INT_TIMER_EN:Enable periodic interrupt
1:Enable
0:Disable
- Bit 1-0 EVERY: 00: every second 01: every minute 10: every hour 11: every day

● **RTC_COMP_LSB_REG : RTC Comensation LSB Register**

Address: 13H				Type: RW				
Bit	Bit7	Bit6	Bit5	Bit4	Bit3	Bit2	Bit1	Bit0
SYMBOL	RTC_COMP_LSB							
Default	0	0	0	0	0	0	0	0

Description

- Bit7-0 This register contains the number of 32-kHz periods to be added into the 32KHz counter every hour [LSB]

● **RTC_COMP_MSB_REG : RTC Compensation MSB Register**

Address: 14H				Type: RW				
Bit	Bit7	Bit6	Bit5	Bit4	Bit3	Bit2	Bit1	Bit0
SYMBOL	RTC_COMP_MSB							
Default	0	0	0	0	0	0	0	0

Description

Bit7-0 This register contains the number of 32-kHz periods to be added into the 32KHz counter every hour [MSB]

● **CLK32KOUT_REG : RTC Compensation MSB Register**

Address: 20H				Type: RW					
Bit	Bit7	Bit6	Bit5	Bit4	Bit3	Bit2	Bit1	Bit0	
SYMBOL	RESERVED					VB_UV_DB_T IME		CLK32KOUT 2_EN	
Default	0	0	0	0	0	0	0	0	

Description

Bit 7-3 Reserved

Bit 2-1 VB_UV_DB_TIME: VCCA under voltage lock out de-bounce time set:
00:2mS; 01:500uS; 10:90uS; 11:30uS

Bit 0 CLK32KOUT2_EN:
1. CLK32KOUT2 output is enabled
0. CLK32KOUT2 output is disabled

5.2.2 Version Register

● **CHIP_NAME_REG : Chip Name Register**

Address: 17H				Type: RO				
Bit	Bit7	Bit6	Bit5	Bit4	Bit3	Bit2	Bit1	Bit0
SYMBOL	CHIP_NAME<11:4>							
Default	1	0	0	0	0	0	0	0

Description

Bit 7-0 CHIP_NAME<11:4>: chip name high 8 bits.

● **CHIP_VER_REG: Chip version Register**

Address: 18H				Type: RO				
Bit	Bit7	Bit6	Bit5	Bit4	Bit3	Bit2	Bit1	Bit0
SYMBOL	CHIP_NAME<3:0>			CHIP_VER<3:0>				
Default	0	1	0	1	0	0	0	0

Description

Bit 7-4 CHIP_NAME<3:0>: chip name low 4 bits.

Bit 3-0 CHIP_VER<3:0>: chip version.

● **OTP_VER_REG: OTP Version Register**

Address: 19H				Type: RO				
Bit	Bit7	Bit6	Bit5	Bit4	Bit3	Bit2	Bit1	Bit0
SYMBOL	RESV			OTP_VER<3:0>				
Default	0	0	0	0	OTP			

Description

Bit 7-4 RESV: RESEVERED
 Bit 3-0 OTP_VER<3:0>: OTP Version NO.

5.2.3 PMU Control Register

● **VB_MON_REG : Battery Voltage Monitor Register**

Address: 21H				Type: RW				
Bit	Bit7	Bit6	Bit5	Bit4	Bit3	Bit2	Bit1	Bit0
SYMBOL	PWRON_STSTS (RO)	RESV	VB_UV_STSTS (RO)	VB_LO_ACT	VB_LO_STSTS (RO)	VB_LO_SEL		
Default	0	0	0	0	0	1	1	0

Description

Bit 7 PWRON_STSTS: PWRON key status
 0: no PWRON key pressed
 1: PWRON key pressed
 This bit is read only
 Bit 6 RESV: RESEVERED
 Bit 5 VB_UV_STSTS: VCCA under voltage lockout status(shut down system if the bit=1)
 This bit is read only
 Bit 4 VB_LO_ACT: VCCA low action
 0: shut down system
 1: insert interrupt
 Bit 3 VB_LO_STSTS: VCCA low voltage status
 0: VCCA>VB_LO_SEL
 1: VCCA<VB_LO_SEL
 This bit is read only
 Bit 2-0 VB_LO_SEL: VCCA low voltage threshold
 000~111: 2.8V~ 3.5V, step=100mV

● **THERMAL_REG : Thermal Control Register**

Address: 22H				Type: RW				
Bit	Bit7	Bit6	Bit5	Bit4	Bit3	Bit2	Bit1	Bit0
SYMBOL	VB_UV_SEL			TSD_TEMP	HOTDIE_TEMP		HOTDIE_STSTS (RO)	TSD_STSTS (RO)
Default	0	0	0	0	0	0	0	0

Description

Bit 7-5 VB_UV_SEL: VCCA under voltage threshold
 000~111: 2.7V~ 3.4V, step=100mV
 Bit 4 TSD_TEMP: Thermal shutdown temperture threshold
 0: 140°C;

- 1: 160°C
- Bit 3-2 HOTDIE_TEMP: Hot-die temperature threshold
00: 85°C; 01: 95°C; 10: 105°C; 11: 115°C
- Bit 1 HOTDIE_STS: Hot-die warning
This bit is read only bit.
- Bit 0 TSD_STS: Thermal shut down

● **PWRON_LP_TIME_REG: Long Press key Interrupt Time Register**

Address: 47H				Type: RW				
Bit	Bit7	Bit6	Bit5	Bit4	Bit3	Bit2	Bit1	Bit0
SYMBOL	RESV	PWRON_LP_TM_SEL		RESV				
Default	0	0	1	0	0	0	0	0

Description

- Bit 7 RESV: RESERVED
- Bit 6-5 PWRON_LP_TM_SEL: Long press PWRON key interrupt time set.
00: 0.5S, 01: 1S, 10: 1.5S, 11: 2S
- Bit 4-0 RESV: RESERVED

● **PWRON_DB_REG: Key De-bounce Time Register**

Address: 48H				Type: RW				
Bit	Bit7	Bit6	Bit5	Bit4	Bit3	Bit2	Bit1	Bit0
SYMBOL	RESV	PWRON_DB_SEL		RESV				
Default	0	1	0	0	0	0	0	0

Description

- Bit 7 RESV: RESERVED
- Bit 6-5 PWRON_DB_SEL: PWRON key de-bounce time set.
00: 32uS, 01: 10mS, 10: 20mS, 11: 40mS
- Bit 4-0 RESV: RESERVED

● **DEV_CTRL_REG: Device Control Register**

Address: 4BH				Type: RW				
Bit	Bit7	Bit6	Bit5	Bit4	Bit3	Bit2	Bit1	Bit0
SYMBOL	INT_FC_EN	PWRON_LP_ACT	PWRON_LP_OFF_TIME		DEV_OFF_RST	RESV	DEV_SL_P	DEV_OFF
Default	0	0	0	0	0	0	0	0

Description

- Bit 7 INT_FC_EN: Interrupt watch dog enable
1: enable(Pin INT will output 2S active level, and then 10mS dis-active level)
0: disable
- Bit 6 Long press key action
0: Turn down PMU 1: Turn down and restart PMU
- Bit 5-4 PWRON_LP_OFF_TIME: PWRON long press time set:
00: 6S, 01: 8S, 10: 10S, 11: 12S

- Bit 3 DEV_OFF_RST: write "1" to reset PMU register.
- Bit 2 RESV: reserved
- Bit 1 DEV_SLP: write "1" to go sleep mode.
- Bit 0 DEV_OFF: write "1" to turn down the PMU.

● **INT_STS_REG(REG[4C]): Interrupt Status Register**

Address: 4CH				Type: RW				
Bit	Bit7	Bit6	Bit5	Bit4	Bit3	Bit2	Bit1	Bit0
SYMBOL	PWRON_FALL_INT (Write 1 clr)	RTC_PERIOD_INT (Write 1 clr)	RTC_ALARM_INT (Write 1 clr)	HOTDIE_INT (Write 1 clr)	PWRON_LP_INT (Write 1 clr)	PWRON_INT (Write 1 clr)	VB_LO_INT (Write 1 clr)	PWRON_RISE_INT (Write 1 clr)
Default	0	0	0	0	0	0	0	0

Description

- Bit 7 PWRON_FALL_INT: PWRON pin falling edge interrupt status.
- Bit 6 RTC_PERIOD_INT: RTC period interrupt status.
- Bit 5 RTC_ALARM_INT: RTC alarm interrupt status.
- Bit 4 HOTDIE_INT: Hot-die interrupt status.
- Bit 3 PWRON_LP_INT: PWRON long press interrupt status.
- Bit 2 PWRON_INT: PWRON interrupt status.
- Bit 1 VB_LO_INT: VCCA low voltage interrupt status.
- Bit 0 PWRON_RISE_INT: PWRON pin rising edge interrupt status.
- Note: 1: interrupt, write "1" to clear. 0: no interrupt

● **INT_MSK_REG(REG[4D]): Interrupt Mask Register**

Address: 4DH				Type: RW				
Bit	Bit7	Bit6	Bit5	Bit4	Bit3	Bit2	Bit1	Bit0
SYMBOL	PWRON_FALL_IM	RTC_PERIOD_IM	RTC_ALARM_IM	HOTDIE_IM	PWRON_LP_IM	PWRON_IM	VB_LO_IM	PWRON_RISE_IM
Default	0	0	0	0	0	0	0	0

Description

- Bit 7 PWRON_FALL_IM: PWRON pin falling edge interrupt mask.
- Bit 6 RTC_PERIOD_IM: RTC period interrupt mask.
- Bit 5 RTC_ALARM_IM: RTC alarm interrupt mask.
- Bit 4 HOTDIE_IM: Hot-die interrupt mask.
- Bit 3 PWRON_LP_IM: PWRON long press interrupt mask.
- Bit 2 PWRON_IM: PWRON interrupt mask.
- Bit 1 VB_LO_IM: VCCA low voltage interrupt mask.
- Bit 0 PWRON_RISE_IM: PWRON pin rising edge interrupt mask.
- Note: 1: mask the interrupt, 0: don't mask the interrupt

● **IO_POL_REG(REG[50]): IO Polarity Register**

Address: 50H				Type: RW				
Bit	Bit7	Bit6	Bit5	Bit4	Bit3	Bit2	Bit1	Bit0
SYMBOL	RESV			SLP_SD		SLP_POL		INT_POL
Default	0	0	0	0	0	0	1	0

Description

- Bit 7-4 RESV: reserved
- Bit 4-3 SLP_SD: SLEEP pin function set:
00: Null, 01: PMU goes to SLEEP mode, 1x: turn down the PMU.
- Bit 1 SLP_POL: SLEEP pin polarity set:
1: active high, 0: active low
- Bit 0 INT_POL: INT pin polarity set:
1: active high, 0: active low

● **OUT_REG(REG[52]): Digital OUT Register**

Address: 52H				Type: RW				
Bit	Bit7	Bit6	Bit5	Bit4	Bit3	Bit2	Bit1	Bit0
SYMBOL	RESV						OUT2	OUT1
Default	0	0	0	0	0	0	0	0

Description

- Bit 7-2 RESV: reserved
- Bit 1 OUT2: OUT2 pin output logic level:
1: high level; 0: low level
- Bit 0 OUT1: OUT1 pin output logic level:
1: high level; 0: low level

● **ON_SOURCE_REG(REG[AE]): ON Source Register**

Address: AEH				Type: RO				
Bit	Bit7	Bit6	Bit5	Bit4	Bit3	Bit2	Bit1	Bit0
SYMBOL	ON_P WRON	ON_EN	ON_ RTC	RESTART _RESETB	RESTART_P WRON_LP	RESV		
Default	0	0	0	0	0	0	0	0

Description

- Bit 7 ON_PWRON: PWRON pressed to turn on the PMU.
- Bit 6 ON_EN: EN rising edge to turn on the PMU.
- Bit 5 ON_RTC: RTC alarm to turn on the PMU.
- Bit 4 RESTART_RESETB: pull down RESETB pin to restart the PMU.
- Bit 3 RESTART_PWRON_LP: long press PWRON key to restart the PMU.
- Bit 2-0 RESV: reserved.

● **OFF_SOURCE_REG(REG[AF]): OFF Source Register**

Address: AFH				Type: RO				
Bit	Bit7	Bit6	Bit5	Bit4	Bit3	Bit2	Bit1	Bit0
SYMBOL	OFF_EN	OFF_S YS_OV	OFF_T SD	OFF_S YS_UV	OFF_DE V_OFF	OFF_P WRON _LP	OFF_U SB_OV _UV	OFF_S YS_LO
Default	0	0	0	0	0	0	0	0

Description

- Bit 7 OFF_EN: EN low level to turn off the PMU.
- Bit 6 OFF_VBV: VCCA over voltage to turn off the PMU.
- Bit 5 OFF_TSD: over temperature to turn off the PMU.
- Bit 4 OFF_VB_UV: VCCA under voltage to turn off the PMU.

- Bit 3 OFF_DEV_OFF: write Reg4B<0>=1 to turn off the PMU.
- Bit 2 OFF_PWRON_LP: Long press PWRON key to turn off the PMU.
- Bit 1 OFF_SLEEP_SD: SLEEP active and Reg50<3:2>=1x to turn off the PMU.
- Bit 0 OFF_VB_LO: VCCA over voltage and Reg21<4> =0 to turn off the PMU.

5.2.4 Power Channel Control/Monitor Registers

● **DCDC_EN_REG : DC-DC Converter Enable Register**

Address: 23H				Type: RW				
Bit	Bit7	Bit6	Bit5	Bit4	Bit3	Bit2	Bit1	Bit0
SYMBOL	BUCK4_EN_MASK	BUCK3_EN_MASK	BUCK2_EN_MASK	BUCK1_EN_MASK	BUCK4_EN	BUCK3_EN	BUCK2_EN	BUCK1_EN
Default	0	0	0	0	Boot0:1111; Boot1:OTP			

Description

- Bit 7-4 BUCK(n)_EN_MASK: BUCKn enable mask
1, BUCK(n)_EN can be wrote
0, BUCK(n)_EN can't be wrote
- Bit 3-0 BUCK(n)_EN: BUCKn enable
1, Enable
0, Disable
The default value is set by boot.

● **SLEEP_DCDC_EN_REG1: Sleep Mode DC-DC Converter Enable Register**

Address: 25H				Type: RW				
Bit	Bit7	Bit6	Bit5	Bit4	Bit3	Bit2	Bit1	Bit0
SYMBOL	RESV				BUCK4_EN_SLP	BUCK3_EN_SLP	BUCK2_EN_SLP	BUCK1_EN_SLP
Default	0	0	0	0	Boot0:1111; Boot1:OTP			

Description

- Bit 7-4 Reserved
- Bit 3-0 BUCK(n)_EN_SLP: BUCKn enable at sleep mode
1, Enable
0, Disable
The default value is set by boot.

● **SLEEP_LDO_EN_REG : Sleep Mode LDO Enable Register**

Address: 26H				Type: RW				
Bit	Bit7	Bit6	Bit5	Bit4	Bit3	Bit2	Bit1	Bit0
SYMBOL	RESV					LDO3_EN_SLP	LDO2_EN_SLP	LDO1_EN_SLP
Default	0	0	0	0	0	Boot0:111; Boot1:OTP		

Description

- Bit 7-3 Reserved.
- Bit 2-0 LDO(n)_EN_SLP: LDO enable at sleep mode
1, Enable

0, Disable

● **LDO_EN_REG : LDO Enable Register**

Address: 27H				Type: RW				
Bit	Bit7	Bit6	Bit5	Bit4	Bit3	Bit2	Bit1	Bit0
SYMBOL	RESV	LDO3_EN_MASK	LDO2_EN_MASK	LDO1_EN_MASK	RESV	LDO3_EN	LDO2_EN	LDO1_EN
Default	0	0	0	0	0	Boot0:111; Boot1:OTP		

Description

- Bit 7 Reserved.
- Bit 6-4 LDO(n)_EN_MASK: LDO enable mask
1, LDO(n)_EN can be wrote
0, LDO(n)_EN can't be wrote
- Bit 3 Reserved.
- Bit 2-0 LDO(n)_EN: LDO enable
1, Enable
0, Disable

● **BUCK_LDO_SLP_LP_REG: BUCK And LDO Sleep Low Power Mode Register**

Address: 2AH				Type: RW				
Bit	Bit7	Bit6	Bit5	Bit4	Bit3	Bit2	Bit1	Bit0
SYMBOL	BUCK12_PAR_ALWAYS_ON_EN	RESV				BUCK12_PAR_EN	BUCK_SLP_LP_EN	LDO_SLP_LP_EN
Default	0	0	0	0	0	OTP	0	0

Description

- Bit 7 BUCK12_PAR_ALWAYS_ON_EN:
1: BUCK1 and BUCK2 work together during light load when in paralle
0: Only BUCK1 work during light load when in paralle
- Bit 6-3 RESV: reserved
- Bit 2 BUCK12_PAR_EN:
1: enable BUCK1 and BUCK2 work in paralle, 0: disable
- Bit 1 BUCK_SLP_LP_EN:
1: enable BUCK work in low power mode in sleep mode, 0:disable
- Bit 0 LDO_SLP_LP_EN:
1: enable LDO work in low power mode in sleep mode, 0: disable

5.2.5 BUCK and LDO Configure Register

● **BUCK1_CONFIG_REG: BUCK1 Configure Register**

Address: 2EH				Type: RW				
Bit	Bit7	Bit6	Bit5	Bit4	Bit3	Bit2	Bit1	Bit0
SYMBOL	BUCK1_ILMAX		BUCK1_DIS_CHRG_EN	BUCK1_RATE		BUCK1_ILMIN		
Default	0	1	1	1	1	0	1	0

Description

- Bit 7-6 BUCK1_ILMAX: BUCK1 maximum inductor's peak current limit
00: 2.5A, 01: 3A, 10: 3.5A, 11: 4A

- Bit 5 BUCK1_DISCHRG_EN: BUCK1 discharge resistor enable bit when shut down
0: disable discharge resistor when shut down
1: enable discharge resistor when shut down
- Bit 4-3 BUCK1_RATE: BUCK1 voltage change rate when DVS
00: 3mV/uS, 01: 6mV/uS, 10: 12.5mV/uS, 11: 25mV/uS
- Bit 2-0 BUCK1_ILMIN: BUCK1 minmum inductor’s peak current
000: 150mA, 001: 200mA, 010: 250mA, 011: 300mA
100: 340mA, 101: 380mA, 110: 420mA, 111: 460mA

● **BUCK1_ON_VSEL_REG: BUCK1 Active Mode Register**

Address: 2FH				Type: RW				
Bit	Bit7	Bit6	Bit5	Bit4	Bit3	Bit2	Bit1	Bit0
SYMBOL	BUCK1_ON_FPWM	BUCK1_PHASE	BUCK1_ON_VSEL					
Default	0	0	Boot0:010111; Boot1:OTP					

Description

- Bit 7 BUCK1_ON_FPWM:
1: force PWM mode in active mode
0: PWM/PFM auto change mode(default)
- Bit 6 BUCK1_PHASE:
0: normal, 1: inverted
- Bit 5-0 BUCK1_ON_VSEL: BUCK1 active mode voltage, 0.7125V~1.45V, step=12.5mV
000 000: 0.7125V
000 001: 0.725V
.....
111 011: 1.45V

111 100: 1.8V
111 101: 2.0V
111 110: 2.2V
111 111: 2.3V

● **BUCK1_SLP_VSEL_REG: BUCK1 Sleep Mode Register**

Address: 30H				Type: RW				
Bit	Bit7	Bit6	Bit5	Bit4	Bit3	Bit2	Bit1	Bit0
SYMBOL	BUCK1_SLP_FPWM	RESV	BUCK1_SLP_VSEL					
Default	0	0	Boot0:010111; Boot1:OTP					

Description

- Bit 7 BUCK1_SLP_FPWM:
1: force PWM mode in sleep mode
0: PWM/PFM auto change mode(default)
- Bit 6 RESV: Reserved
- Bit 5-0 BUCK1_SLP_VSEL: BUCK1 sleep mode voltage , 0.7125V~1.45V, step=12.5mV
000 000: 0.7125V
000 001: 0.725V
.....
111 011: 1.45V

111 100: 1.8V
111 101: 2.0V
111 110: 2.2V
111 111: 2.3V

● **BUCK2_CONFIG_REG: BUCK2 Configure Register**

Address: 32H					Type: RW			
Bit	Bit7	Bit6	Bit5	Bit4	Bit3	Bit2	Bit1	Bit0
SYMBOL	BUCK2_ILMAX		BUCK2_DIS CHRG_EN	BUCK2_RATE		BUCK2_ILMIN		
Default	0	1	1	1	1	0	1	0

Description

- Bit 7-6 BUCK2_ILMAX: BUCK2 maximum inductor’s peak current limit
00: 2.5A, 01: 3A, 10: 3.5A, 11: 4A
- Bit 5 BUCK2_DISCHRG_EN: BUCK2 discharge resistor enable bit when shut down
0: disable discharge resistor when shut down
1: enable discharge resistor when shut down
- Bit 4-3 BUCK2_RATE: BUCK2 voltage change rate when DVS
00: 3mV/uS, 01: 6mV/uS, 10: 12.5mV/uS, 11: 25mV/uS
- Bit 2-0 BUCK2_ILMIN: BUCK2 minmum inductor’s peak current
000: 150mA, 001: 200mA, 010: 250mA, 011: 300mA
100: 340mA, 101: 380mA, 110: 420mA, 111: 460mA

● **BUCK2_ON_VSEL_REG: BUCK2 Active Mode Register**

Address: 33H					Type: RW			
Bit	Bit7	Bit6	Bit5	Bit4	Bit3	Bit2	Bit1	Bit0
SYMBOL	BUCK2_O N_FPWM	BUCK2 _PHAS E	BUCK2_ON_VSEL					
Default	0	0	Boot0:010111; Boot1:OTP					

Description

- Bit 7 BUCK2_ON_FPWM:
1: force PWM mode in active mode
0: PWM/PFM auto change mode(default)
- Bit 6 BUCK2_PHASE:
0: normal, 1: inverted
- Bit 5-0 BUCK2_ON_VSEL: BUCK2 active mode voltage, 0.7125V~1.45V, step=12.5mV
000 000: 0.7125V
000 001: 0.725V
.....
111 011: 1.45V

111 100: 1.8V
111 101: 2.0V
111 110: 2.2V
111 111: 2.3V

● **BUCK2_SLP_VSEL_REG: BUCK2 Sleep Mode Register**

Address: 34H					Type: RW			
Bit	Bit7	Bit6	Bit5	Bit4	Bit3	Bit2	Bit1	Bit0
SYMBOL	BUCK2_S LP_FPWM	RESV	BUCK2_SLP_VSEL					
Default	0	0	Boot0:010111; Boot1:OTP					

Description

- Bit 7 BUCK2_SLP_FPWM:
1: force PWM mode in sleep mode
0: PWM/PFM auto change mode(default)

- Bit 6 RESV: Reserved
- Bit 5-0 BUCK2_SLP_VSEL: BUCK2 sleep mode voltage, 0.7125V~1.45V, step=12.5mV
 000 000: 0.7125V
 000 001: 0.725V

 111 011: 1.45V

 111 100: 1.8V
 111 101: 2.0V
 111 110: 2.2V
 111 111: 2.3V

● **BUCK3_CONFIG_REG: BUCK3 Configure Register**

Address: 36H				Type: RW				
Bit	Bit7	Bit6	Bit5	Bit4	Bit3	Bit2	Bit1	Bit0
SYMBOL	BUCK3_ON_FPWM	BUCK3_PHASE	BUCK3_DISCHRG_EN	BUCK3_ILMAX		BUCK3_ILMIN		
Default	0	0	1	0	1	0	1	0

Description

- Bit 7 BUCK3_ON_FPWM: 1: force PWM mode
0: PWM/PFM auto change mode(default)
- Bit 6 BUCK3_PHASE: 0: normal, 1: inverted
- Bit 5 BUCK3_DISCHRG_EN: BUCK3 discharge resistor enable bit when shut down
0: disable discharge resistor when shut down
1: enable discharge resistor when shut down
- Bit 4-3 BUCK3_ILMAX: BUCK3 maximum inductor's peak current limit
00: 1.5A, 01: 2A, 10: 2.5A, 11: 3A
- Bit 2-0 BUCK3_ILMIN: BUCK3 minimum inductor's peak current
000: 50mA, 001: 100mA, 010: 150mA, 011: 200mA
100: 250mA, 101: 300mA, 110: 350mA, 111: 400mA

● **BUCK4_CONFIG_REG: BUCK4 Configure Register**

Address: 37H				Type: RW				
Bit	Bit7	Bit6	Bit5	Bit4	Bit3	Bit2	Bit1	Bit0
SYMBOL	RESV	BUCK4_PHASE	BUCK4_DISCHRG_EN	BUCK4_ILMAX		BUCK4_ILMIN		
Default	0	0	1	0	1	0	1	0

Description

- Bit 7 RESV: Reserved
- Bit 6 BUCK4_PHASE: 0: normal, 1: inverted
- Bit 5 BUCK4_DISCHRG_EN: BUCK4 discharge resistor enable bit when shut down
0: disable discharge resistor when shut down
1: enable discharge resistor when shut down
- Bit 4-3 BUCK4_ILMAX: BUCK4 maximum inductor's peak current limit
00: 2A, 01: 2.5A, 10: 3A, 11: 3.5A
- Bit 2-0 BUCK4_ILMIN: BUCK4 minimum inductor's peak current
000: 50mA, 001: 100mA, 010: 150mA, 011: 200mA
100: 250mA, 101: 300mA, 110: 350mA, 111: 400mA

● **BUCK4_ON_VSEL_REG: BUCK4 Active Mode Register**

Address: 38H				Type: RW				
--------------	--	--	--	----------	--	--	--	--

Bit	Bit7	Bit6	Bit5	Bit4	Bit3	Bit2	Bit1	Bit0
SYMBOL	BUCK4_ON_FPWM	RESV		BUCK4_ON_VSEL				
Default	0	0	0	Boot0:11001; Boot1:OTP				

Description

- Bit 7 BUCK4_ON_FPWM:
1: force PWM mode in active mode
0: PWM/PFM auto change mode(default)
- Bit 6-5 RESV: Reserved
- Bit 4-0 BUCK4_ON_VSEL: BUCK4 active mode voltage, 0.8V~3.5V, step=100mV
00000: 0.8V
00001: 0.9V
.....
11001: 3.3V
11010: 3.4V
11011: 3.5V
111xx: 3.5V

● **BUCK4_SLP_VSEL: BUCK4 Sleep Mode Register**

Address: 39H				Type: RW				
Bit	Bit7	Bit6	Bit5	Bit4	Bit3	Bit2	Bit1	Bit0
SYMBOL	BUCK4_SLP_FPWM	RESV		BUCK4_SLP_VSEL				
Default	0	0	0	Boot0:11001; Boot1:OTP				

Description

- Bit 7 BUCK4_SLP_FPWM:
1: force PWM mode in sleep mode
0: PWM/PFM auto change mode(default)
- Bit 6-5 RESV: Reserved
- Bit 4-0 BUCK4_SLP_VSEL:BUCK4 sleep mode voltage, 0.8V~3.5V, step=100mV
00000: 0.8V
00001: 0.9V
.....
11001: 3.3V
11010: 3.4V
11011: 3.5V
111xx: 3.5V

● **LDO1_ON_VSEL_REG: LDO1 Active Voltage Selection Register**

Address: 3BH				Type: RW				
Bit	Bit7	Bit6	Bit5	Bit4	Bit3	Bit2	Bit1	Bit0
SYMBOL	RESV	LDO1_IMAX	LDO1_DISCHRG_EN	LDO1_ON_VSEL				
Default	0	0	1	Boot0:00010; Boot1:OTP				

Description

- Bit 7 RESV: Reserved
- Bit 6 LDO1_IMAX: LDO1 current limit
0: nomal, 1: 130%*nomal
- Bit 5 LDO1_DISCHRG_EN: LDO1 discharge resistor enable bit when shut down
0: disable discharge resistor when shut down
1: enable discharge resistor when shut down
- Bit 4-0 LDO1_ON_VSEL: LDO1 active mode voltage, 0.8V~3.4V, step=0.1V

00000: 0.8V
 00001: 0.9V

 11001: 3.3V
 11010: 3.4V

● **LDO1_SLP_VSEL_REG:LDO1 Sleep Voltage Selection Register**

Address: 3CH				Type: RW				
Bit	Bit7	Bit6	Bit5	Bit4	Bit3	Bit2	Bit1	Bit0
SYMBOL	RESV			LDO1_SLP_VSEL				
Default	0	0	0	Boot0:00010; Boot1:OTP				

Description

Bit 7-5 RESV: Reserved
 Bit 4-0 LDO1_SLP_VSEL: LDO1 sleep mode voltage, 0.8V~3.4V, step=0.1V
 00000: 0.8V
 00001: 0.9V

 11001: 3.3V
 11010: 3.4V

● **LDO2_ON_VSEL_REG: LDO2 Active Voltage Selection Register**

Address: 3DH				Type: RW				
Bit	Bit7	Bit6	Bit5	Bit4	Bit3	Bit2	Bit1	Bit0
SYMBOL	RESV	LDO2_IM AX	LDO2_D ISCHRG _EN	LDO2_ON_VSEL				
Default	0	0	1	Boot0:01010; Boot1:OTP				

Description

Bit 7 RESV: Reserved
 Bit 6 LDO2_IMAX: LDO2 current limit
 0: nomal, 1: 130%*nomal
 Bit 5 LDO2_DISCHRG_EN: LDO2 discharge resistor enable bit when shut down
 0: disable discharge resistor when shut down
 1: enable discharge resistor when shut down
 Bit 4-0 LDO2_ON_VSEL: LDO2 active mode voltage, 0.8V~3.4V, step=0.1V
 00000: 0.8V
 00001: 0.9V

 11001: 3.3V
 11010: 3.4V

● **LDO2_SLP_VSEL_REG:LDO2 Sleep Voltage Selection Register**

Address: 3EH				Type: RW				
Bit	Bit7	Bit6	Bit5	Bit4	Bit3	Bit2	Bit1	Bit0
SYMBOL	RESV			LDO2_SLP_VSEL				
Default	0	0	0	Boot0:01010; Boot1:OTP				

Description

Bit 7-5 RESV: Reserved
 Bit 4-0 LDO2_SLP_VSEL: LDO2 sleep mode voltage, 0.8V~3.4V, step=0.1V
 00000: 0.8V
 00001: 0.9V

....
 11001: 3.3V
 11010: 3.4V

● **LDO3_ON_VSEL_REG: LDO3 Active Voltage Selection Register**

Address: 3FH				Type: RW				
Bit	Bit7	Bit6	Bit5	Bit4	Bit3	Bit2	Bit1	Bit0
SYMBOL	RESV	LDO3_IM AX	LDO3_D ISCHRG _EN	LDO3_ON_VSEL				
Default	0	0	1	Boot0:00010; Boot1:OTP				

Description

Bit 7 RESV: Reserved
 Bit 6 LDO3_IMAX: LDO3 current limit
 0: nomal, 1: 130%*nomal
 Bit 5 LDO3_DISCHRG_EN: LDO3 discharge resistor enable bit when shut down
 0: disable discharge resistor when shut down
 1: enable discharge resistor when shut down
 Bit 4-0 LDO3_ON_VSEL: LDO3 active mode voltage, 0.8V~3.4V, step=0.1V
 00000: 0.8V
 00001: 0.9V

 11001: 3.3V
 11010: 3.4V

● **LDO3_SLP_VSEL_REG:LDO3 Sleep Voltage Selection Register**

Address: 40H				Type: RW				
Bit	Bit7	Bit6	Bit5	Bit4	Bit3	Bit2	Bit1	Bit0
SYMBOL	RESV			LDO3_SLP_VSEL				
Default	0	0	0	Boot0:00010; Boot1:OTP				

Description

Bit 7-5 RESV: Reserved
 Bit 4-0 LDO3_SLP_VSEL: LDO3 sleep mode voltage, 0.8V~3.4V, step=0.1V
 00000: 0.8V
 00001: 0.9V

 11001: 3.3V
 11010: 3.4V

Chapter 6 Thermal Management

6.1 Overview

For reliability and operability concerns, the absolute maximum junction temperature of RK805 has to be below 125°C.

Depending on the thermal mechanical design (Smartphone, Tablet, Personal Navigation Device, etc), the system thermal management software and worst case thermal applications, the junction temperature might be exposed to higher values than those specified above.

Therefore, it is recommended to perform thermal simulations at device level (Smartphone, Tablet, Personal Navigation Device, etc) with the measured power of the worst case UC of the device.

6.2 Package Thermal Characteristics

Table 6-1 provides the thermal resistance characteristics for the package used on this device.

Table 6-1 Thermal Resistance Characteristics

PACKAGE (QFN4X4-32)	POWER(W)	θ_{JA} (°C/W)	θ_{JB} (°C/W)	θ_{JC} (°C/W)
RK805	2	45	21	2

Note: The testing PCB is based on 4 layers, 114mm x 76 mm, 1.6mm thickness, Ambient temperature is 85°C.