

DESCRIPTION

LC1761 dual, low-noise, low-dropout regulator delivers at least 300mA of continuous output current. The output voltage for each regulator is set independently by trimming. Output voltages are selectable in 100mV steps within a range of 1.2V to 3.5V. Typical output noise is 47uVrms, and PSRR is 73dB at 100Hz. The LC1761 includes two independent logic-controlled shutdown inputs and allows the output of each regulator to be turned off independently.

LC1761 includes high accuracy voltage reference, error amplifier, current limit circuit and output driver module.

LC1761 has excellent load and line transient response and good temperature characteristics, which can assure the stability of chip and power system. And it uses trimming technique to guarantee output voltage accuracy within $\pm 2\%$.

LC1761 is available in SOT-23-6 package which is lead(Pb)-free

TYPICAL APPLICATION

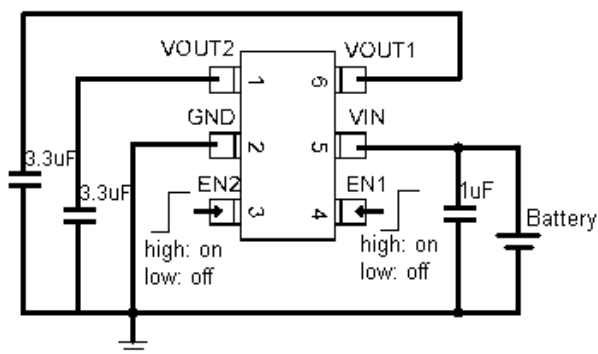

APPLICATION HINTS

NOTE:

Input capacitor ($C_{in}=1\mu F$) and Output capacitor ($C_{out}=1\mu F/3.3\mu F$) are recommended in all application circuit.

FEATURES

- Two low dropout voltage regulators
- 300mA output current for each LDO
- 25uA operating supply current per LDO
- Low 47uVRMS output noise
- Standby Mode: 0.1uA
- Low 160mV dropout at 300mA load
- 73dB PSRR at 100Hz
- Excellent Line regulation: 0.05%/V
- Independent Shutdown controls
- 1.2V to 3.5V Factory-Preset Output
- Output Current Limit
- Highly Accurate: $\pm 2\%$ ($\pm 1\%$ customized)

APPLICATIONS

- Cellular phones
- Cordless phones and radio communication equipment
- Battery Powered equipment
- Notebook and hand-hold equipment
- Wireless LAN
- GPS receivers

ELECTRICAL CHARACTERISTICS

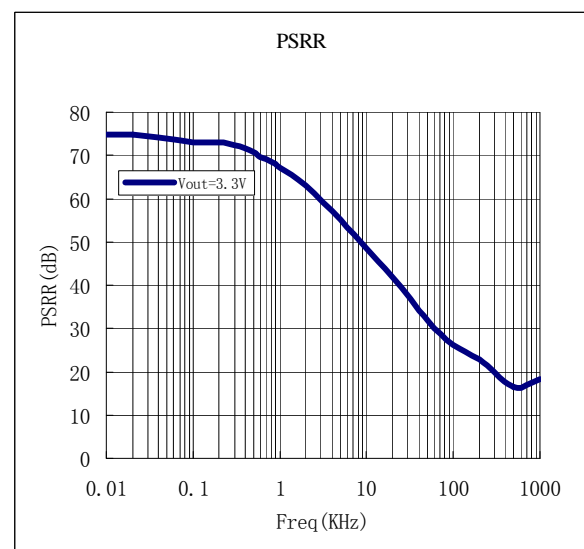

ORDERING INFORMATION

LC1761 [1](#) [2](#) [3](#) [4](#) [5](#)

Code	Description
1	Temperature&Rohs: C:-40~85°C ,Pb Free Rohs Std.
2	Package type: B6:SOT-23-6 B6B: SOT23-6 B-type Pin Out
3	Packing type: TR:Tape&Reel (Standard)
4	CH1 Output voltage: e.g. 15=1.5V 28=2.8V
5	CH2 Output voltage: e.g. 15=1.5V 28=2.8V

MARKING DESCRIPTON

L: Product Code
X: Output Voltage

Code	Vout1	Vout2	Code	Vout1	Vout2
B	1.5V	2.8V	M	2.8V	1.8V
C	1.5V	3.0V	O	2.8V	2.8V
D	1.5V	3.3V	P	2.8V	3.0V
E	1.5V	4.0V	Q	3.0V	2.5V
G	1.8V	2.5V	R	3.0V	3.0V
H	1.8V	2.8V	S	3.0V	3.3V
I	1.8V	3.0V	T	3.3V	1.8V
J	1.8V	3.3V	U	3.3V	3.3V
a	1.2V	2.5V	b	2.8V	1.2V
c	2.8V	1.3V	d	2.5V	2.8V
e	2.5V	3.3V	f	2.8V	3.3V
g	1.3	2.8V			

Z: The Year of manufacturing,"7" stands for year 2007,"8" stands for year 2008,and "0" stands for year 2010.

Z: The week of manufacturing. "A" stands for week 1,"Z" stands for week 26,"A" stands for week 27," Z" stands for week 52.

PIN CONFIGURATION

Marking		LC1761CB6TR□□
LXZZ	L: Product Code	
	X: Output Voltage	
	ZZ: Date Code	
LXZZ " " for B-type	L:Product Code	
	X:Output Voltage	
	ZZ: Date Code	
Vss	Ground Pin	
Vin	Supply Voltage Input	
Vout1	CH1 Output Voltage	
CE1	Chip Enable1	
CE2	Chip Enable2	
Vout2	CH2 Output Voltage	

ABSOLUTE MAXIMUM RATING

Parameter	Value
Max Input Voltage	8V
Operating Junction Temperature(Tj)	125°C
Ambient Temperature(Ta)	-40°C -85°C
Power Dissipation	SOT-23-6 250mW
Storage Temperature(Ts)	-40°C -150°C
Lead Temperature & Time	260°C,10S

Note:
Exceed these limits to damage to the device.
Exposure to absolute maximum rating conditions may affect device reliability.

RECOMMENDED WORK CONDITIONS

Parameter	Value
Input Voltage Range	Max. 6V
Ambient Temperature	-40°C -85°C

ELECTRICAL CHARACTERISTICS

(Test Conditions: $C_{in}=1\mu F, C_{out}=3.3\mu F, T_A=25^\circ C$, unless otherwise specified.)

LC1761, For Arbitrary Output Voltage

Symbol	Parameter	Conditions	Min	Typ	Max	Units
V_{in}	Input Voltage				6	V
V_{out}	Output Voltage	$V_{in}=\text{Set } V_{out}+1V$ $1mA \leq I_{out} \leq 30mA$	$V_{out} \times 0.98$	$V_{out} \times 1$	$V_{out} \times 1.02$	V
$I_{out} (\text{Max.})$	Maximun Output Current	$V_{in}-V_{out}=1V$	300			mA
V_{drop}	Dropout Voltage, $V_{out} \geq 2.8V$	$I_{out}=100mA$		50	80	mV
		$I_{out}=300mA$		160	220	mV
$\frac{\Delta V_{out}}{\Delta V_{in} \cdot V_{out}}$	Line Regulation	$I_{out}=40mA$ $2.8V \leq V_{in} \leq 6V$		0.05	0.2	%/V
$\Delta V_{out} / \Delta I_{out}$	Load Regulation	$V_{in}=\text{Set } V_{out}+1V$ $1mA \leq I_{out} \leq 300mA$		30	50	mV
I_{ss}	Supply Current	$V_{in}=\text{Set } V_{out}+1V$		50	100	μA
$I_{standby}$	Supply Current (Standby)	$V_{in}=\text{Set } V_{out}+1V$ $V_{ce}=\text{GND}$		0.1	1.0	μA
$\frac{\Delta V_{out}}{\Delta T \cdot V_{out}}$	Output Voltage Temperature Coefficiency	$I_{out}=30mA$		± 100		ppm/ $^\circ C$
PSRR	Ripple Rejection	$F=100Hz,$ Ripple=0.5Vp-p $V_{in}=\text{Set } V_{out}+1V$		70		dB
I_{lim}	Short Current Limit	$V_{out}=0V$		500		mA
V_{ceh}	CE Input Voltage "H"		1.5		V_{in}	V
V_{cel}	CE Input Voltage "L"		0		0.25	V
e_n	Output Noise	$BW=10Hz \sim 100kHz$		47		μV_{rms}

BLOCK DIAGRAM

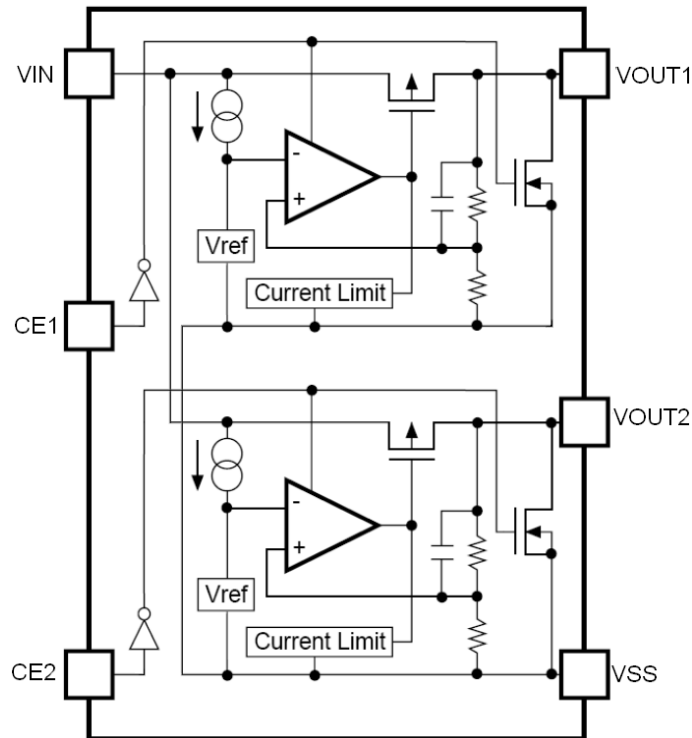

Explanation

LC1761 series are highly accurate, dual, low noise, CMOS low dropout voltage regulators. The output voltage for each regulator is set independently by trimming. Voltages are selectable in 100mV steps within a range of 1.2V to 3.5V. It also can be customized on command.

LC1761 includes high accuracy voltage reference, error amplifier, current limit circuit and output driver module.

LC1761 has excellent load and line transient response and good temperature characteristics, which can assure the stability of chip and power system. And it uses trimming technique to guarantee output voltage accuracy within $\pm 2\%$.

TYPICAL PERFORMANCE CHARACTERISTICS

1) Output Voltage vs. Output Current (with output short protection)

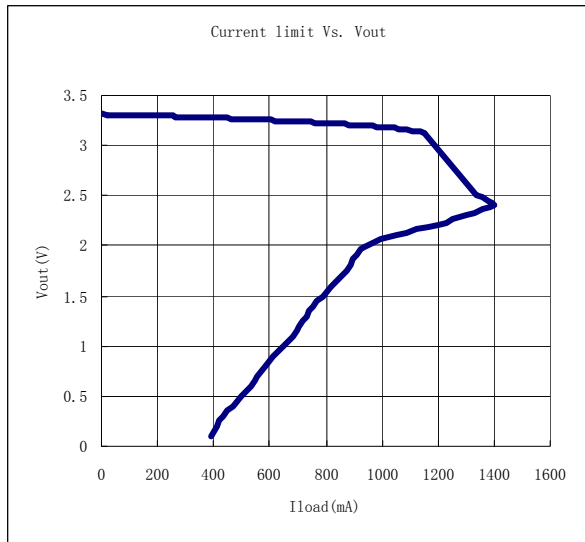

2) Output Voltage vs. Input Voltage

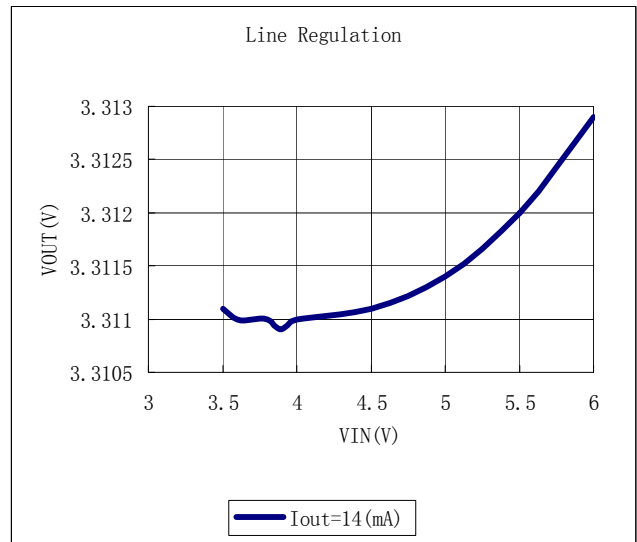

3) Dropout Voltage vs. Output Current

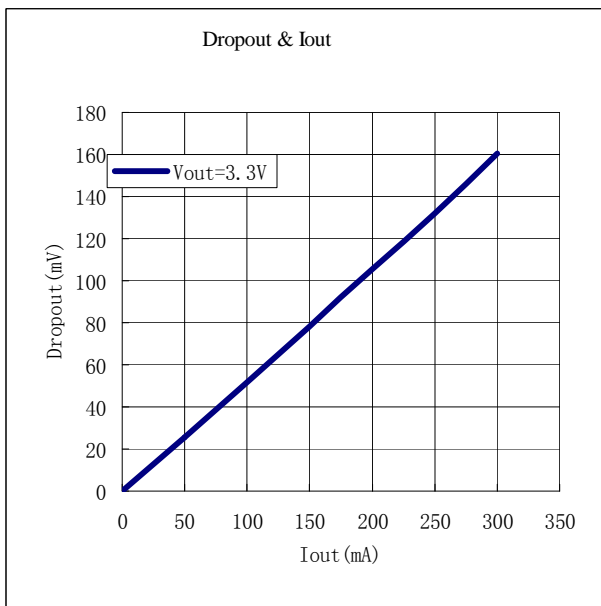

4) Ripple rejection vs. Frequency

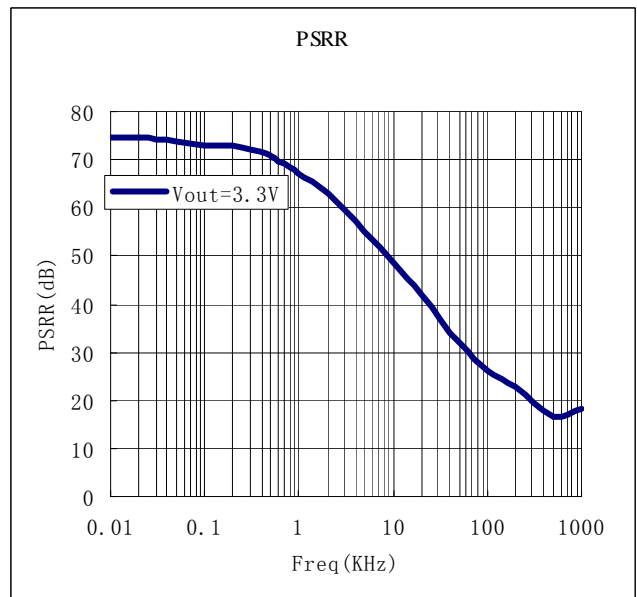

5) Line transient response

$C_{in}=C_{out}=1\mu F$ $I_{out}=25mA$ $V_{out}=3.3V$

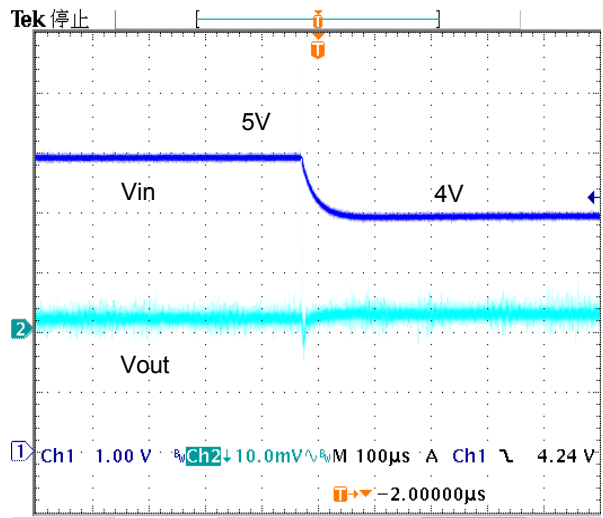
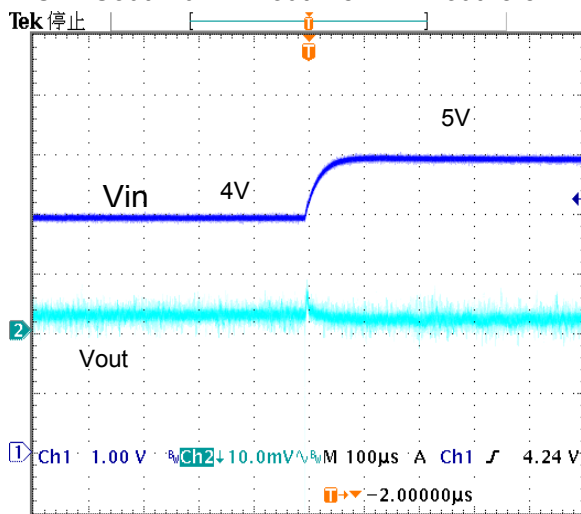

6) Load transient response

$C_{in}=C_{out}=1\mu F$ $V_{in}=4.5V$ $V_{out}=3.3V$

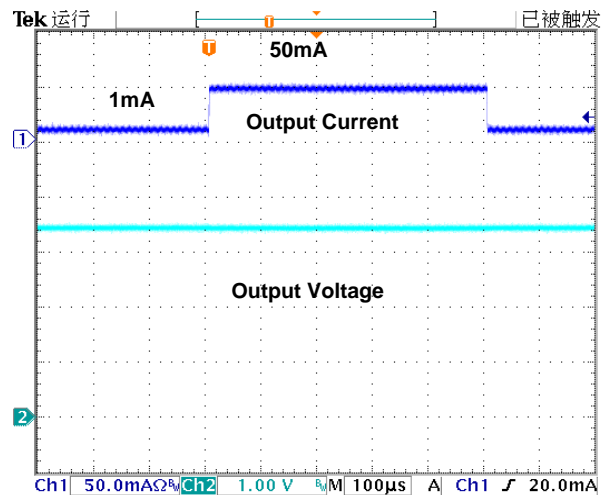
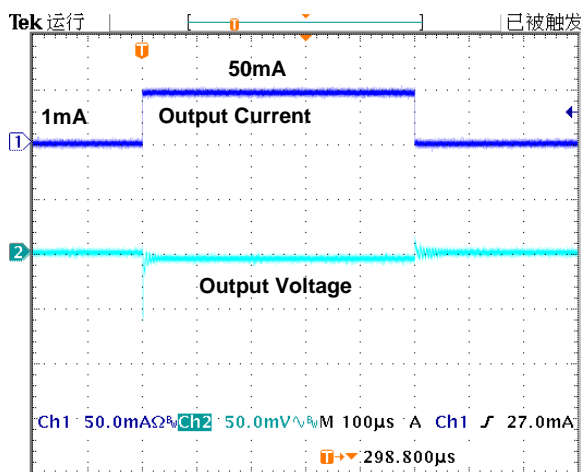

7) Start up from EN

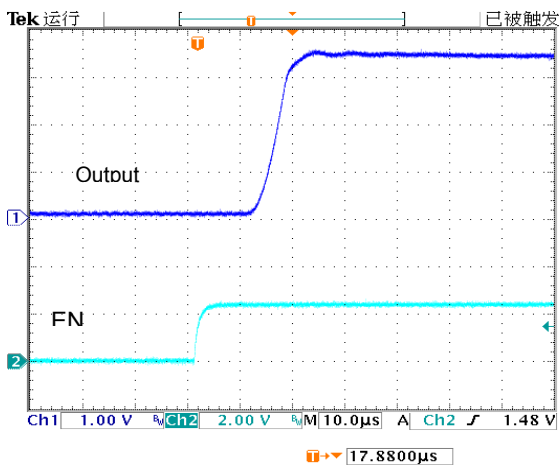

8) Shut down from EN

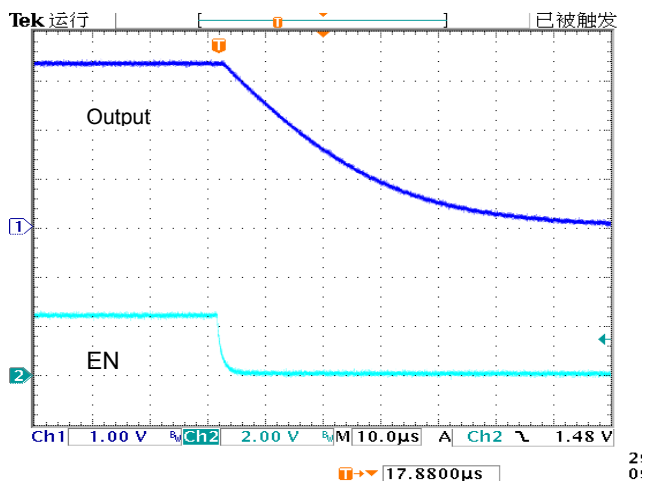

PACKAGE LINE

Package	SOT-23-6	Devices per reel	3000Pcs	Unit	mm
<p>Package dimension:</p> <p>The technical drawing illustrates the SOT-23-6 package dimensions. The top view shows a total width of 2.9 ± 0.2 mm, with a central lead spacing of 1.9 ± 0.2 mm. Individual lead widths are 0.95 mm. The side view shows a maximum height of 2.8 ± 0.3 mm and a body height of 1.6 ± 0.2 mm. Lead heights are 0.4 ± 0.1 mm. The side view also shows a lead length of 1.1 ± 0.2 mm, a lead thickness of 0.8 ± 0.1 mm, and a lead tip thickness of 0.15 ± 0.1 mm. A lead tip radius of 0.2 mm minimum is specified. The bottom view shows the package from the underside.</p>					