



82389 MESSAGE PASSING COPROCESSOR A MULTIBUS II BUS INTERFACE CONTROLLER

- **Highly Integrated VLSI Device**
 - Single-Chip Interface for the Parallel System Bus (IEEE 1296)
 - Interrupt Handling/Bus Arbitration Functions
 - Dual-Buffer Input and Output DMA Capabilities
 - Nine 32-Byte High Speed FIFOs
- **Multiple Interface Support**
 - Complete Protocol Support of the PSB Bus (Message Passing)
 - Processor Independent Interface (8-, 16-, or 32-Bit CPU)
 - Low-Cost 8-Bit Microcontroller Interface
 - Dual-Port Memory Interface
- **High Performance Coprocessing Functions**
 - Offloads CPU for Communication and Bus Interfacing
 - 40 Megabytes/sec Burst Transfer Speed
 - Optimized for Real-Time Response (Max. 900 ns for 32-Byte Interrupt Packet)
- **CMOS Technology**
- **149-Pin PGA Package (15 x 15 Grid)**

The MPC 82389 is a highly integrated VLSI device that maximizes the performance of a Multibus II based multiprocessor system. It integrates the functions of bus arbitration, data transmit packetizing, error handling and interrupt control. Because of these integrated functions, the host CPU can be offloaded to utilize the maximum bus performance and subsequently increase the system throughput. The MPC 82389 also supports geographic addressing by providing access to the local interconnect registers for reference and control.

The MPC 82389 is designed to interface with an 8-, 16-, or 32-bit processor. The Parallel System Bus (PSB) performance is not affected by the CPU buswidth or bandwidth. The data on the PSB is burst transferred at the maximum bus speed of 40 Megabytes/second regardless of CPU bus performance. Such performance is possible due to decoupling of the CPU from the PSB.

This data sheet is supplemented by a *MPC User's Manual*, Intel literature number 176526-002. The *MPC User's Manual* provides detailed information regarding hardware and software board design information. In addition, the IEEE 1296 specification can provide more information regarding the MULTIBUS II bus architecture.

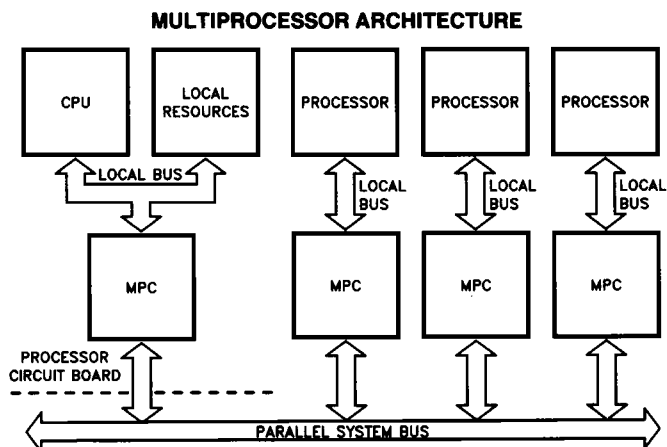

290145-1

1.0 MPC 82389 INTRODUCTION

The 82389 Message Passing Coprocessor (MPC) is a highly integrated CMOS VLSI device which interfaces any microprocessor to the MULTIBUS II Parallel System Bus (PSB). The PSB is defined for easy access and sharing of resources in a processing environment which allows the existence of both intelligent and non-intelligent add-in boards. The MPC complements the MULTIBUS II environment by providing an optimized interface for the PSB at its maximum bandwidth. The MPC also offloads the host CPU, thus increasing system throughput, by providing the necessary bus arbitration, message passing protocol, error handling and interrupt control for a MULTIBUS II system. Figure 1-1 shows an example of the MPC's message passing performance.

1.1 Functional Overview

The MPC 82389 is a bus interface controller which offloads the host CPU for interprocessor communication on the PSB. The MPC 82389 features four interfaces which support a variety of data transfer operations.

1.1.1 MPC 82389 INTERFACES

The three primary interfaces to the MPC (PSB Interface, Host CPU Interface and Interconnect Interface) all function asynchronously to one another. This is accomplished through the use of internal latches and FIFOs that allow references to occur simultaneously on all interfaces. In addition to the three primary interfaces, the MPC contains a Dual-Port Interface which provides compatibility with past system implementations and software.

—PSB Interface

The PSB Interface is the synchronized, shared data pathway in the MULTIBUS II system.

—Host CPU Interface

The Host CPU Interface is a set of addressable registers and ports that is the private pathway for the local microprocessor on the MULTIBUS II board.

—Interconnect Interface

The Interconnect Interface provides a path for added board functionality that is independent from the host CPU.

—Dual-Port Interface

The Dual-Port Interface supports shared memory references.

1.1.2 MAJOR OPERATIONS

—Unsolicited and Solicited Message Passing

The unsolicited and solicited message passing protocol is an interprocessor communication protocol which allows an intelligent agent* on the PSB to communicate with another agent without any CPU intervention at full PSB speed.

—PSB Memory and I/O Single Cycle Access

The MPC performs single cycle read/write transfers from the host to memory and I/O locations across the PSB. The MPC handles bus arbitration, parity generation and error detection without CPU intervention.

—Local Interconnect Access

The host CPU and other agents on the PSB can access local interconnect space via the MPC.

*An agent is any device with an interface to the PSB.

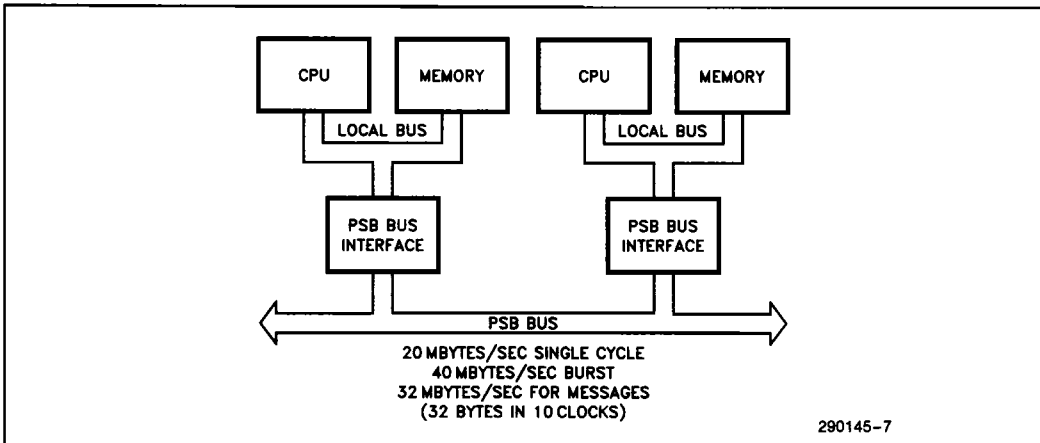

Figure 1-1. Message Passing Performance Example

—Remote Interconnect Access

The MPC enables the host CPU to access remote interconnect locations assigned to other PSB agents.

—Dual-Port Memory Access Support

Other PSB agents can access dual-port memory via the MPC.

—Central Services Module (CSM) support

The MPC has a minimal set of built-in CSM support features which allow the CSM to be incorporated into any MULTIBUS II board design.

2.0 MESSAGE PASSING PROTOCOL

The MULTIBUS II architecture designates the data transfer protocol between agents on the PSB as message passing. Message passing allows agents to transfer variable amounts of data at maximum PSB speed. The MPC fully supports the PSB's standardized message passing protocol. The entire handshaking procedure between agents on the PSB is handled by the MPC without CPU intervention.

There are two types of messages that can be transmitted from one agent to another: Unsolicited Messages and Solicited Messages.

2.1 Unsolicited Messages

Unsolicited messages are short, fixed-length messages that can arrive unexpectedly. Unsolicited messages can be transmitted without explicit buffer allocation and without synchronization between sending and receiving agents on the PSB. Unsolicited messages are often referred to as intelligent or virtual interrupts, since they can be used as a signaling mechanism between boards, replacing traditional system interrupts and freeing the CPU from having to poll for information. In addition, unsolicited messages allow for up to 28 bytes of user data.

2.2 Solicited Messages

Solicited messages are used to transfer large amounts of data. Up to 16 Mbytes (less 1 byte) of data can be transferred in a single solicited message transmission sequence. Solicited message transfers require the receiving agent to explicitly allocate a buffer. Buffer negotiation between sending and receiving agents is handled using unsolicited messages as follows:

- A buffer request message initiates a solicited message transfer. It requests the receiving agent to allocate a buffer large enough to hold the solicited data.
- A buffer grant message must be returned by the receiving agent before the solicited data can be transferred. The buffer grant informs the sending agent's MPC that a buffer has been allocated and indicates that the receiving agent's MPC is ready to begin the data transfer.
- A buffer reject message is returned by the receiving agent if a buffer for the solicited data cannot be provided. In this case, the rejection is final, and no further action is required.

If a DMA controller handles the solicited message transfer, DMA controller setup is also needed. Typically, the sending agent programs its DMA controller immediately before sending a buffer request, and the receiving agent programs its DMA controller immediately before sending a buffer grant.

Once solicited buffer negotiation is complete (the sending agent's MPC has received a buffer grant), the agents transfer the data without further intervention. The data is sent as a series of solicited packets on the sending agent's local bus. The MPCs perform transfer and routing across the PSB automatically. At the end of the solicited data transfer, both the sending and receiving agents get a completion indication from their local MPC.

3.0 MPC 82389 INTERFACES

The MPC 82389 features a total of 4 interfaces. The three primary interfaces are the Host CPU Interface, PSB Interface and the Interconnect Interface. The MPC also has a Dual-Port Memory Interface which provides compatibility with past system implementations and software. Figure 3-1 shows the four MPC bus interfaces.

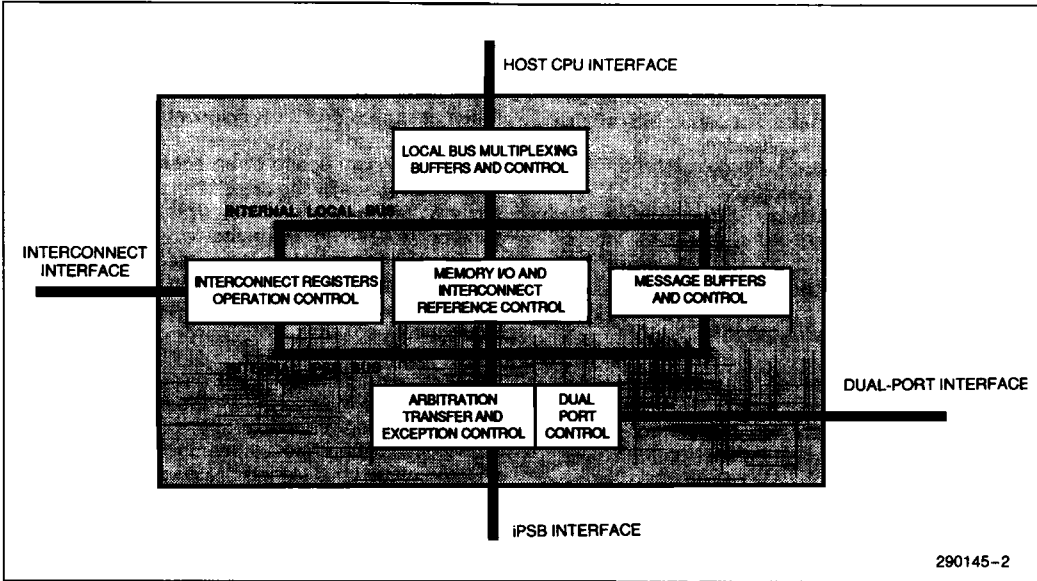

290145-2

Figure 3-1. MPC Bus Interfaces

3.1 Host CPU Interface

The Host CPU Interface connects an 8-, 16-, or 32-bit processor to the MPC. The Host CPU Interface supports direct references to memory, I/O, and interconnect address space on the PSB. The entire Host CPU Interface is composed of three sub-interfaces: Register Sub-Interface, Reference Sub-Interface and DMA Sub-Interface.

—Register Sub-Interface

The Register Sub-Interface is composed of a bank of 8-bit registers on the Host CPU Interface. These registers provide the configuration, status and command interface for the host CPU. A host register operation is independent from operations which may be in progress at the MPC's other interfaces. However, some host register operations are dependent on the internal state of the MPC. In host register operations, the maximum duration is decided by the strobe width. Thus, the number of wait states required at the local interface is under the control of the host CPU.

—Reference Sub-Interface

The Reference Sub-Interface supports direct references to memory, I/O, and interconnect address space on the PSB. Memory and I/O references are initiated by the CPU to the MPC. The MPC responds

to a memory or I/O reference by putting the CPU on hold while arbitrating for the PSB. The CPU is held in wait states until the reference is complete or until a bus exception condition occurs on the PSB. The Reference Sub-Interface supports both read and write operations to the registers. The local interconnect address space is differentiated from the interconnect address on the PSB by the bit pattern stored in the MPC's slot address register.

—DMA Sub-Interface

The DMA Sub-Interface supports data transfers between the local memory and the MPC during solicited message operations. The DMA Interface is designed to support either two-cycle or fly-by (single-cycle) read/write transfers. For two-cycle operations, the DMA controller performs one cycle into memory and another cycle to the MPC; a read command is used to get data from the MPC and a write command is used to put data into the MPC. Fly-by operations allow data to be transferred during a single bus cycle; a fly-by transfer will use a write command to get data from the MPC (corresponding to a memory write) and a read command to put data into the MPC (corresponding to a memory read). The higher performance possible with fly-by transfers mandates the alignment of data on 4-byte boundaries.

3.2 Parallel System Bus Interface

The Parallel System Bus (PSB) Interface is a full 32-bit interface to other boards in the MULTIBUS II chassis. The PSB Interface supports PSB arbitration, data transfer and error handling.

—Parallel System Bus Arbitration

The MPC begins PSB access arbitration upon a request which is generated inside the MPC. This request could be the result of a synchronized PSB memory, I/O or interconnect reference request or a message packet transmit request from the CPU.

—Data Transfer

The PSB Interface contains all the address/data lines and necessary control signals for data transfer. These control signals provide the control mechanism between agents during transfer operations.

—Error Handling

The MPC monitors errors generated during data transfer operations. The MPC recognizes data integrity problems on the PSB and bus timeout conditions.

3.3 Interconnect Interface

The Interconnect Interface is an independent 8-bit communication interface which allows the MPC to

be connected to a microcontroller. (It is highly recommended that an 8051 or similar microcontroller be used on the Interconnect Interface.) This microcontroller will perform tasks such as board configuration at startup and local diagnostics.

The interconnect space of an agent is the only required bus space by the IEEE 1296 specification and has a 512-byte register range. Within this space the microcontroller can store the local operating and configuration parameters associated with the agent. For example, local diagnostics can be executed out of the microcontroller and the results posted in the interconnect space.

Local resources on an agent gain access to interconnect space through the MPC's interconnect bus. A microcontroller connects to the interconnect bus for intelligent handling of interconnect operations. All interconnect bus signals are asynchronous to the bus clock and to the local bus signals.

3.4 Basic Implementation with the MPC 82389

Figure 3-2 shows a basic implementation of the MPC 82389. Included in this implementation is the Interconnect Interface, the Host CPU Interface and the PSB Interface.

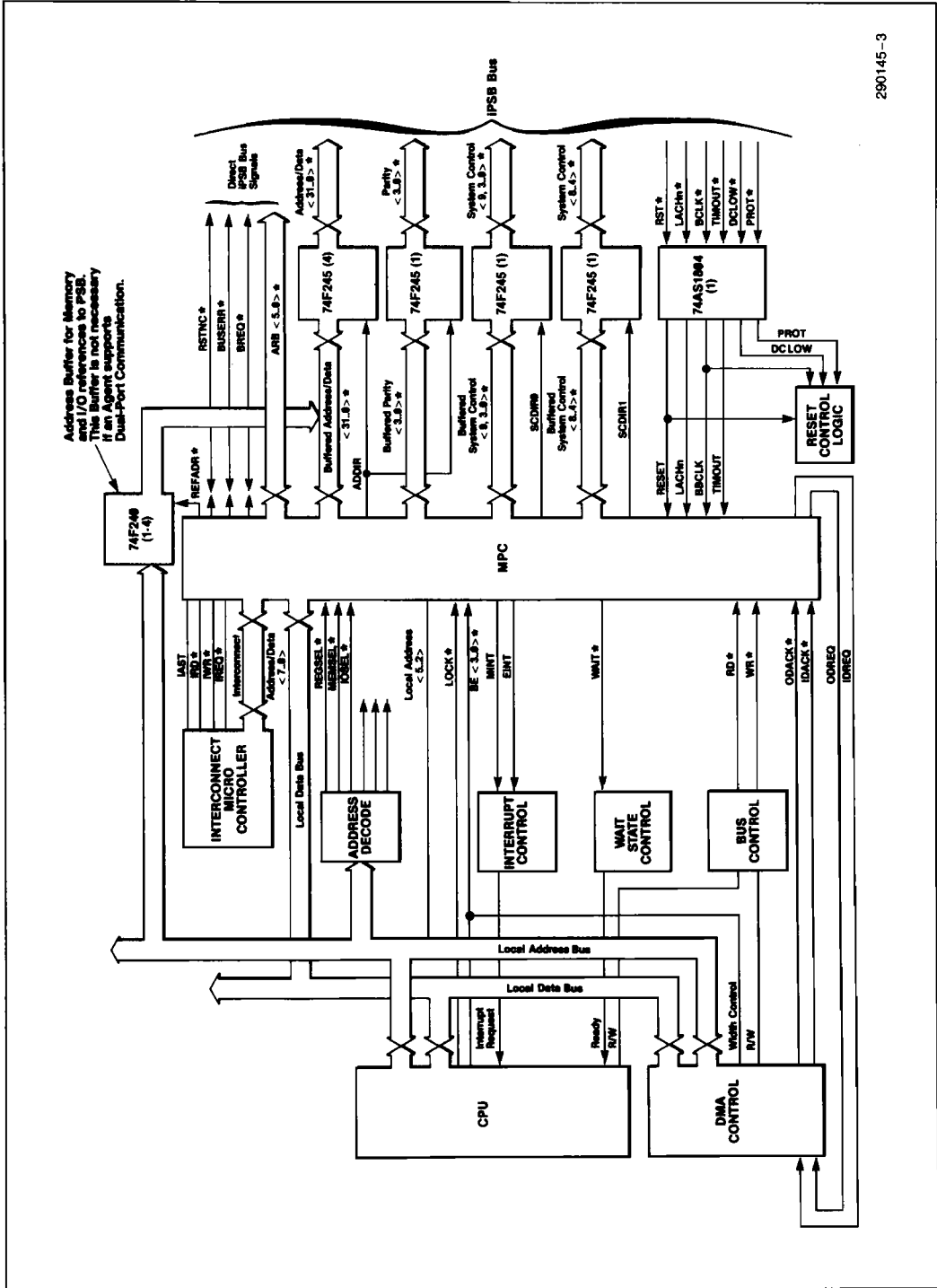

Figure 3-2. MPC Implementation to Support References

290145-3

3.5 Dual-Port Interface

The Dual-Port Interface supports shared memory accesses between agents on the PSB. In order to fully implement dual-port memory, some additional dual-port memory controller logic is required. Figure 3-3 shows an example of the MPC implemented with dual-port memory.

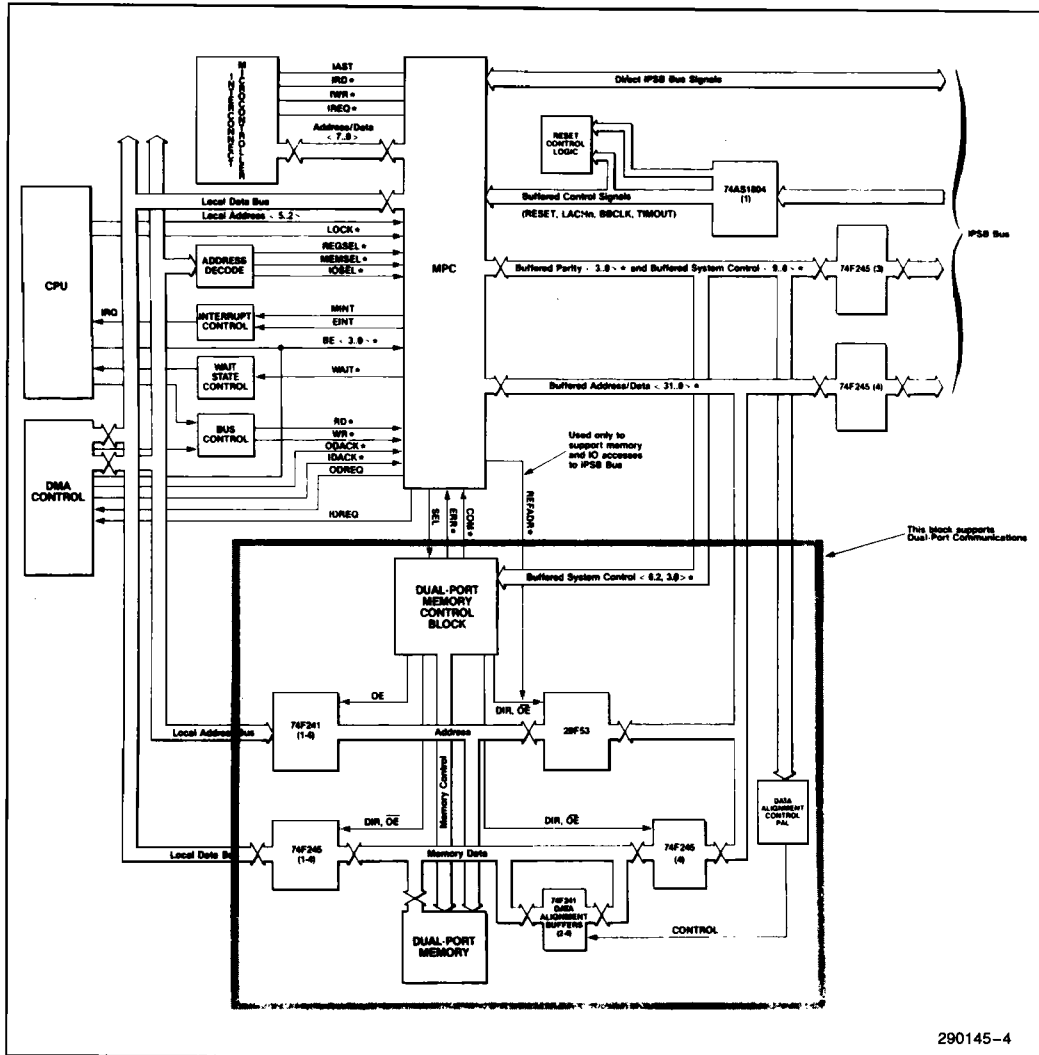

Figure 3-3. The MPC Implemented with Dual-Port Memory

4.0 MPC 82389 OPERATIONS

The primary function of the MPC 82389 is MULTIBUS II message passing. In addition to message passing, the MPC performs the following functions:

- Memory and I/O Reference
- Local Interconnect Reference
- Remote Interconnect Reference
- Interconnect Replier Operations
- Dual-Port Replier Operations
- Central Services Module Support

4.1 MULTIBUS II Message Passing

The MPC manages the routing of message packets as they flow between the interfaces of each MULTIBUS II agent in the system. For message traffic on the PSB, message decode logic on the PSB input bus determines message routing through the MPC. For the Host CPU Interface and Interconnect Interface, the MPC defines a signal protocol for message passing.

MULTIBUS II messages, both unsolicited and solicited, are transferred through nine dedicated internal

FIFO buffers between the Host CPU Interface and PSB Interface. Unsolicited messages are intelligent (also called virtual) interrupts which notify the receiving agent to prepare for the receipt of solicited messages. Unsolicited messages use the Transmit/Error FIFO and the Receive FIFO. The Transmit FIFO holds a 32-byte packet for transmittal across the PSB. If there is an error in transmission, the Transmit FIFO becomes the Error FIFO, where the errant message can be read back along with error status. The Receive FIFO is a circular queue of four 32-byte buffers from which unsolicited messages are received from the PSB by the host CPU.

Solicited messages consist of information data packets which are transmitted between agents. Solicited messages use the Solicited Input FIFO and Solicited Output FIFO. These FIFOs are dual 32-byte buffers which are used for the temporary storage of solicited data packets as they travel between the Host CPU Interface and the PSB Interface. The solicited output header logic attaches header information to the solicited data packet before sending it onto the PSB. All FIFOs are able to operate independently and concurrently, thus creating a true multitasking message passing environment. Figure 4-1 shows the nine dedicated internal FIFO buffers.

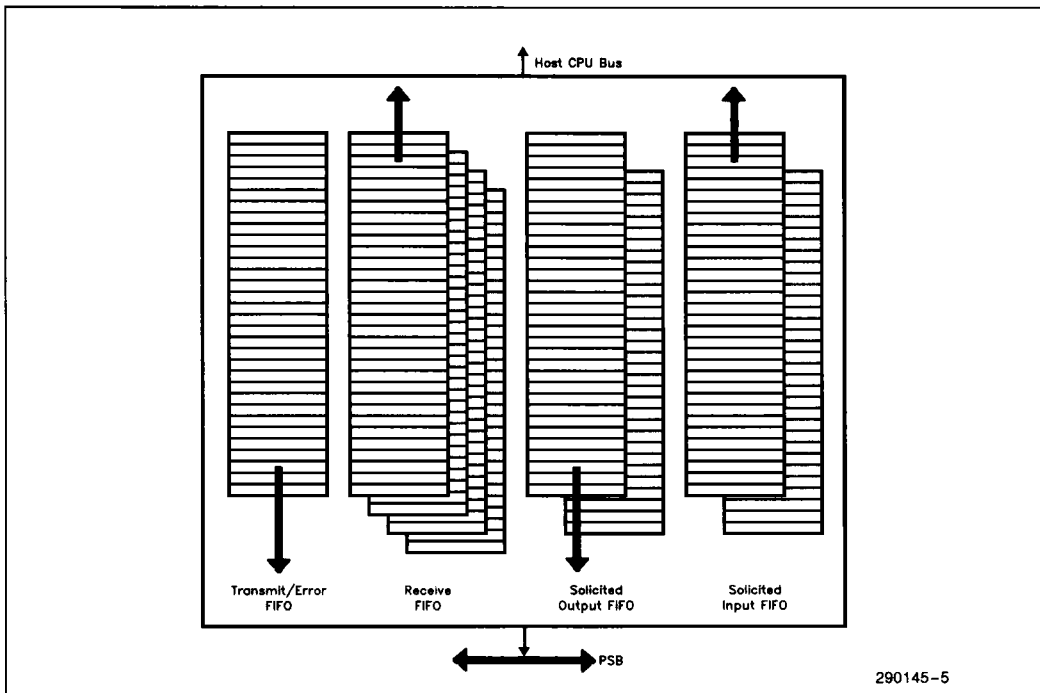

290145-5

Figure 4-1. The MPC Uses Nine Dedicated Internal 32-Byte FIFO Buffers

4.1.1 UNSOLICITED TRANSMIT/RECEIVE

Unsolicited message passing sequences occur between the Host CPU Interface and the PSB Interface using FIFOs internal to the MPC. FIFO status is available on the Host CPU Interface and in state machines internal to the MPC. On the Host CPU Interface, host register operations write bytes to the Transmit FIFO and read bytes from the Receive FIFO. On the PSB, the MPC manages the emptying and filling of the Transmit and Receive FIFOs using MULTIBUS II message passing protocol and the Transmit and Receive FIFOs on another agent's MPC. For detailed information about message passing protocol across the PSB, see the *IEEE 1296 High Performance Synchronous 32-bit Bus Standard*.

4.1.2 SOLICITED INPUT/OUTPUT

Solicited transfers are pre-negotiated using unsolicited message sequences. Dedicated FIFOs (Solicited Input FIFO and Solicited Output FIFO) are then used for the transfer of solicited data packets. This allows large amounts of data to be moved between agents independently of unsolicited messages. In most cases, the solicited transfer occurs under DMA control, freeing the host CPU to handle other activities. The DMA controller uses the input channel DMA request/acknowledge and output channel DMA request/acknowledge signals along with the read/write signal to stream the data from/to the solicited FIFOs. On the PSB, the data is transferred in bursts using MULTIBUS II message passing protocol and similar solicited FIFOs on another agent's MPC. The MPCs add header information to the packets on the PSB, indicating source, destination and length. Data transfers through the solicited FIFOs can be set up for 8, 16 or 32 bits of data width on the Host CPU Interface, but occur at full 32-bit width on the PSB.

4.2 Memory and I/O References

Remote memory or I/O reference operations are Host CPU Interface operations that involve an access through the MPC to a resource across the PSB. This resource can be a dumb memory or I/O board. The remote reference can only be done through the MPC as a single cycle operation (no block transfers) to the remote resource and can involve an unknown number of wait states. Many MULTIBUS II CPU boards use an alternate path (such as the iLBX bus found on Intel iSBC boards) that is an independent extension of the local bus for full-speed and block transfer operations.

The host CPU initiates a memory or I/O reference by activating memory select (MEMSEL†) or I/O select (IOSEL), A<5-2>, BE<3-0>, with a RD or WR strobe. If necessary, LOCK is activated to allow

back-to-back accesses across the PSB, holding all other agents off the memory or I/O resource. The MPC activates its WAIT output to indicate that the operation is in progress.

The data for reference operation proceeds through the MPC and PSB to a memory or I/O address on another agent. A data path from D<31-0> through the buffered address/data bus (BAD<31-0>) is used for the data transfer. Data is latched internally in a reference data latch. Parity is generated to the PSB on BPAR <3-0> for the data on each write operation and checked on data read. Completion of the operation is indicated when the MPC deactivates the WAIT output.

The memory or I/O address for the reference operation is routed around the MPC through an external reference address latch. This latch is controlled by the REFADR signal from the MPC.

4.3 Local Interconnect Reference

A local interconnect reference operation is an access by the host CPU to the interconnect records maintained by the local interconnect microcontroller. The geographic interconnect address is preloaded into a pair of registers internal to the MPC. The upper 5 bits of the interconnect address determine whether the operation is local or remote. A data path from D<7-0> to the interconnect address/data bus (IAD<7-0>) is used. The microcontroller uses the interconnect request (IREQ) output to sense the request. The request is serviced by the interconnect microcontroller through a sequence of accesses to registers within the MPC using the interconnect address strobe (IAST), interconnect read (IRD), and interconnect write (IWR) strobes, and the IAD multiplexed bus. The WAIT signal is used as for memory and I/O references to indicate completion of the local interconnect reference operation.

4.4 Remote Interconnect Reference

A remote interconnect reference is an access by the host CPU to interconnect space on another agent. The host CPU requests a remote interconnect reference by writing the interconnect address to the same register used in the local interconnect request, except that the upper 5 bits of the interconnect address indicate the slot address of another agent on the PSB. The data flows through the MPC as in a remote memory or I/O reference, except that the data transfer occurs only on D<7-0>. The remote microcontroller services the request through an interconnect replier operation.

†* indicates that the signal is active low.

4.5 Interconnect Replier Operations

When another agent performs a remote interconnect reference request, it gains access to local interconnect space through the MPC. The MPC decodes an interconnect request on the PSB for a slot ID match and signals the interconnect microcontroller independently of the local bus interface. The microcontroller then handles the request in the same way as a local interconnect request.

4.6 Dual-Port Replier Operations

Other agents can access dual-port memory via the MPC. A memory access request on the PSB is decoded by the MPC for an address range match and serviced by the dual-port controller (external circuitry must be provided). The MPC provides only the handshaking path. Data transfer occurs directly on the $\overline{\text{BAD}}$ bus. If a bus exception occurs while a dual-port memory reference is in progress, the MPC will signal the dual-port controller to terminate the operation.

4.7 Central Services Modular Support

The IEEE 1296 specification defines the Central Services Module (CSM) that resides in Slot 0 of a MULTIBUS II system. The CSM is responsible for these functions:

- reset sequencing (generates reset signal on the PSB)
- assignment of card slot and arbitration IDs during reset initialization
- generation of system wide clocks for all agents (bus clocks and time of day)
- generation of bus timeout
- battery back-up of system constants (host ID, time of day, etc.)

The MPC has a minimal set of built-in CSM support features that allow the incorporation of CSM into any MULTIBUS II board design. The MPC, interconnect microcontroller, and a small amount of external circuitry can fully implement the CSM automatically when the board is inserted into Card Slot 0.

4.7.1 ADDITIONAL CSM REQUIREMENTS

In addition to the interconnect microcontroller and the MPC, the following functions must be provided through external logic:

- clock generation
- PSB reset generation
- cold/warm start detection
- PSB timeout generation

The clock generator provides the bus clock ($\overline{\text{BCLK}}$) and central clock ($\overline{\text{CCLK}}$) signals to the PSB. The reset generator provides the hardware reset line ($\overline{\text{RESET}}$) to all agents on the PSB. Cold/warm start detection circuitry distinguishes between a power-up reset and a warm-start reset; on power-up the CSM assigns arbitration and slot IDs. The PSB timeout function determines when the PSB is hung.

See the *MPC User's Manual* (Intel literature number 176526-002) and the *CSM002 Hardware Reference Manual* (Intel literature number 459706-001) for more information about the CSM.

5.0 MPC 82389 PIN DESCRIPTIONS

This section describes each signal pin (or group of pins) on the MPC. Emphasis is placed on giving as much information as possible to ease the task of designing hardware associated with the MPC signal pins. The pins are described in terms of these functional groups:

- PSB interface
- local bus (host CPU) interface
- dual-port memory control
- interconnect bus interface

5.1 PSB Signals

The PSB signals provide the interface to other boards in the MULTIBUS II chassis. Very little support circuitry is required for this part of the board. Only high-current drivers and reset control logic is needed. Some MPC signal pins have built-in open collector high-current drivers that allow connection directly to the PSB. For complete information on the PSB, see the *IEEE 1296 High Performance Synchronous 32-bit Bus Standard* document.

PSB signals fall into five groups, depending on function:

- arbitration operation signal group
- address/data bus signal group
- system control signal group
- central control signal group
- exception operation signal group

Unless otherwise stated, all PSB signals are synchronous to the bus clock.

NOTE:

High current drivers used to drive the buffered address/data ($\overline{\text{BAD}}$) bus should be controlled with minimal logic. This is to limit propagation delays and avoid possible bus contention problems. Ensure that the placement of these drivers and the MPC is done as close to the PSB (the P1 connector on a MULTIBUS II board) as possible to minimize signal stub lengths and capacitive loading.

5.1.1 ARBITRATION OPERATION SIGNAL GROUP

These MPC pins are used by an agent to obtain exclusive access to the PSB. They are all high-current drive, open-collector signals. Below is a description of each signal.

$\overline{\text{BREQ}}$ (Bus Request). $\overline{\text{BREQ}}$ is a bidirectional open-collector signal that connects directly to the PSB. As an input to the MPC, it indicates that agents are awaiting access to the bus. As an output, the MPC asserts $\overline{\text{BREQ}}$ to request PSB access.

$\overline{\text{ARB}}\langle 5-0 \rangle$ (Arbitration). $\overline{\text{ARB}}\langle 5-0 \rangle$ are bidirectional, open-collector signals that connect directly to the PSB. $\overline{\text{ARB}}\langle 5-0 \rangle$ are used (during normal operation) to identify the mode and arbitration priority of an agent during an arbitration cycle. During system initialization (while reset is active), the central services module (CSM) drives these signals to initialize slot and arbitration IDs.

5.1.2 ADDRESS/DATA BUS SIGNAL GROUP

This signal group includes a 32-bit multiplexed address/data path ($\overline{\text{BAD}}\langle 31-0 \rangle$) and the byte parity signals ($\overline{\text{BPAR}}\langle 3-0 \rangle$). These signals require buffering through bus transceivers before connection to the PSB. This signal group also includes the bus transceiver control signals (ADDIR and $\overline{\text{REFADR}}$).

$\overline{\text{BAD}}\langle 31-0 \rangle$ (Buffered Address/Data). $\overline{\text{BAD}}\langle 31-0 \rangle$ are the 32 bidirectional, multiplexed address/data signals that provide the interface to the PSB address/data bus ($\overline{\text{AD}}$) when buffered through 74F245 or equivalent bus transceivers.

NOTE:

Do not use pull-up resistors to drive the $\overline{\text{BAD}}$ bus high. If pull-up resistors are present, the MPC cannot guarantee valid logic states with proper timing.

$\overline{\text{BPAR}}\langle 3-0 \rangle$ (Buffered Parity). $\overline{\text{BPAR}}$ are four signals that provide parity for the 32-bit $\overline{\text{BAD}}$ bus. These bidirectional lines connect to the PSB $\overline{\text{PAR}}\langle 3-0 \rangle$ signals through a 74F245 or equivalent transceiver. These signals are used to receive byte parity for incoming data and to drive byte parity for outgoing data.

ADDIR (Address/Data Direction). ADDIR is an output that provides direction control over the bus transceivers buffering the $\overline{\text{BAD}}\langle 31-0 \rangle$ and $\overline{\text{BPAR}}\langle 3-0 \rangle$ signals. In the high state, this signal causes the transceivers to drive address/data information along with parity onto the PSB. In the low state, this signal causes address/data information and parity to be received from the PSB.

$\overline{\text{REFADR}}$ (Reference Address Enable). $\overline{\text{REFADR}}$ is an output used to enable external reference address buffers during reference operations. Asserting this signal places the reference address onto the $\overline{\text{BAD}}$ bus. The address path enabled by this signal is only used for memory and I/O reference operations to the PSB. It is not used during message passing or for PSB references to interconnect space.

5.1.3 SYSTEM CONTROL SIGNAL GROUP

The system control signal group on the PSB provides a control mechanism between agents during transfer operations.

$\overline{\text{BSC}}\langle 9-0 \rangle$ (Buffered System Control). $\overline{\text{BSC}}\langle 9-0 \rangle$ is a group of ten bidirectional signals that connect to the PSB through 74F245 or equivalent transceivers. Agents on the PSB use these signals for commands or status, depending on the phase of the operation. The function of each of these lines during request and reply phases of transfer operations is summarized in Table 5-1.

Table 5-1. Summary of $\overline{\text{BSC}}$ Signal Functions

Signal	Request Phase	Reply Phase
$\overline{\text{BSC0}}$	Bus Owner in Request Phase	Bus Owner in Reply Phase
$\overline{\text{BSC1}}$	LOCK	LOCK
$\overline{\text{BSC2}}$	Data Width	End-of-Transfer
$\overline{\text{BSC3}}$	Data Width	Bus Owner Ready
$\overline{\text{BSC4}}$	Address Space	Replying Agent Ready
$\overline{\text{BSC5}}$	Address Space	Agent Status
$\overline{\text{BSC6}}$	Read/Write Data Transfer	Agent Status
$\overline{\text{BSC7}}$	Reserved	Agent Status
$\overline{\text{BSC8}}$	Even Parity on $\overline{\text{BSC}}\langle 7-4 \rangle$	Even Parity on $\overline{\text{BSC}}\langle 7-4 \rangle$
$\overline{\text{BSC9}}$	Even Parity on $\overline{\text{BSC}}\langle 3-0 \rangle$	Even Parity on $\overline{\text{BSC}}\langle 3-0 \rangle$

NOTE:

The end-of-transfer (EOT) handshake in single-cycle operations is indicated by $\overline{\text{BSC}}\langle 4,3,2 \rangle$ as follows: the requesting MPC drives $\overline{\text{BSC}}\langle 3,2 \rangle$ and waits for the replier to drive $\overline{\text{BSC}}4$; when the replier responds, the EOT handshake is complete.

SCDIR $\langle 1,0 \rangle$ (System Control Direction).

SCDIR $\langle 1,0 \rangle$ are output signals that provide direction control of the 74F245 transceivers driving and receiving $\overline{\text{BSC}}\langle 9-0 \rangle$. SCDIR0 provides control for $\overline{\text{BSC}}\langle 9,3-0 \rangle$, while SCDIR 1 provides control for $\overline{\text{BSC}}\langle 8-4 \rangle$. When either signal is high, the bus transceiver drives $\overline{\text{BSC}}$ signals onto the PSB. When either signal is low, signals on the PSB are driven onto the $\overline{\text{BSC}}$ lines.

5.1.4 CENTRAL CONTROL SIGNAL GROUP

The central control signal group provides bus status and control information for devices operating on the PSB. The CSM, residing in slot 0 of the MULTIBUS II backplane, generates $\overline{\text{BCLK}}$, LACHn, and RESET.

BBCLK (Buffered Bus Clock). BBCLK is received by the MPC to synchronize all operations on the PSB. This input should be connected to $\overline{\text{BCLK}}$ (on the PSB) using a 74AS1804 or equivalent inverting buffer. The falling edge of $\overline{\text{BCLK}}$ provides all system timing references. BBCLK normally has a fixed operating frequency of 10 MHz.

NOTE:

$\overline{\text{BCLK}}$ can be varied from DC to 10 MHz. You may use this feature for single-stepping on the PSB during debugging.

LACHn (ID Latch). LACHn is an input signal used during initialization of slot and arbitration IDs (where "n" is the slot number). When the RESET signal is active, LACHn indicates when a slot or arbitration ID is available and should be latched. LACHn is an active high input and should be connected to the LACHn signal on the PSB with a 74AS1804 or equivalent inverting buffer.

RESET. Reset is an input that places the MPC in a known state. Only the parts of the MPC involved with initialization of slot and arbitration IDs remain unaffected. RESET is an active high input and should be connected to the $\overline{\text{RST}}$ signal on the PSB with a 74AS1804 or equivalent inverting buffer.

If the MPC is used in a CSM implementation, the interconnect microcontroller and some external logic controls RESET. On power up, the CSM generates the RESET signal to the backplane. Within a few clock cycles, receiving MPCs complete their internal reset. Table 5-2 summarizes the states of MPC signal outputs while the RESET signal is active.

Table 5-2. Signal States During Reset

Signal	Reset State	Signal	Reset State
$\overline{\text{BREQ}}$	Z(H)	$\overline{\text{ARB}} < 5-0 >$	Z(H)
$\overline{\text{BAD}} < 31-0 >$	Z	$\text{D} < 31-0 >$	Z
ADDIR	L	$\overline{\text{SEL}}$	H
$\overline{\text{REFADR}}$	H	WAIT	H
$\overline{\text{BSC}} < 9-0 >$	Z	$\text{ODREQ}, \text{IDREQ}$	L
$\text{SCDIR} < 1,0 >$	L	MINT, EINT	L
$\overline{\text{BUSERR}}$	Z(H)	$\overline{\text{RSTNC}}$	L

NOTE:

H = Electrical high state.

L = Electrical low state.

Z = High impedance (tri-state).

$\overline{\text{RSTNC}}$ (Reset Not Complete). Agents assert $\overline{\text{RSTNC}}$ during reset to extend the initialization time period beyond the time that RESET allows. $\overline{\text{RSTNC}}$ is a bidirectional OR-tied signal on the PSB that is low when one or more agents have not completed their reset requirements. Agents cannot perform bus operations while $\overline{\text{RSTNC}}$ is asserted. However, agents may access local interconnect space if your firmware implementation allows such access. $\overline{\text{RSTNC}}$ is an open-collector signal with high-current drive that connects directly to the PSB.

5.1.5 Exception Operation Signal Group

The exception operation signal group indicates exception errors on the PSB.

$\overline{\text{BUSERR}}$ (Bus Error). The MPC asserts $\overline{\text{BUSERR}}$ when a data integrity problem on the PSB is detected during a transfer operation. Possible problems are: detection of a parity error on the $\overline{\text{BAD}}$ bus or $\overline{\text{BSC}}$ lines, or a protocol error associated with the $\overline{\text{BSC}}$ lines. $\overline{\text{BUSERR}}$ is a bidirectional, open-collector signal with high current drive that connects directly to the PSB.

TIMOUT (Timeout). TIMOUT , as an input from the PSB, is used to detect a bus timeout condition. The CSM activates this signal when it determines that an agent is taking too much time asserting a handshake signal, or if a bus owner has maintained bus ownership for an excessive length of time. The exact amount of time is a fixed value relative to BBCLK that is approximately 10,000 clock cycles (1 ms @ 10 MHz). TIMOUT is an active high input to the MPC and must be connected to the TIMOUT signal of the PSB through a 74AS1804 or equivalent inverting buffer.

When the MPC is configured for CSM operation, TIMOUT becomes an output, generating the timeout condition to all agents on the PSB. In this case, the TIMOUT pin should be connected to the PSB by a 74F242 driver or equivalent.

5.2 Dual-Port Memory Control Signals

The MPC provides these signals ($\overline{\text{SEL}}$, $\overline{\text{COM}}$, $\overline{\text{ERR}}$) to support dual-port memory. In order to fully implement dual-port memory, some additional dual-port memory controller logic is required.

$\overline{\text{SEL}}$ (Select). The $\overline{\text{SEL}}$ output indicates that a dual-port memory access is in progress. $\overline{\text{SEL}}$ initiates dual-port operations and may be used to enable the dual-port data buffers onto the $\overline{\text{BAD}}$ bus. When the MPC receives the EOT handshake, or if the MPC detects an exception, it deactivates $\overline{\text{SEL}}$.

$\overline{\text{COM}}$ (Complete). $\overline{\text{COM}}$ is an input to the MPC. The dual-port memory controller asserts $\overline{\text{COM}}$ to indicate completion of a dual-port access. $\overline{\text{COM}}$ is assumed to be synchronous to the bus clock. After the memory controller has asserted $\overline{\text{COM}}$, the MPC asserts the replier ready ($\overline{\text{BSC4}}$) signal on the next bus clock. The memory controller cannot deassert $\overline{\text{COM}}$ until the EOT handshake is complete on the PSB. This requires that the memory controller monitor the PSB for the EOT handshake.

$\overline{\text{ERR}}$ (Error). $\overline{\text{ERR}}$, an input to the MPC, is asserted by the dual-port memory controller to signal a memory data parity error. $\overline{\text{ERR}}$ must be stable (high or low) whenever $\overline{\text{COM}}$ is asserted. The MPC responds to this signal by completing the replier handshake on the PSB using a *data error* agent error code. This signal may be asynchronous to the bus clock since it is qualified by the $\overline{\text{COM}}$ signal.

5.3 Local Bus Signals

The MPC local bus allows many types of microprocessors, perhaps with differing data widths, byte alignment, and bit ordering, to connect to the MULTIBUS II PSB. This microprocessor is often referred to as the *host CPU* on the MULTIBUS II processor board. The MPC has five signal groups on the local bus:

- data bus
- address/status signals
- transfer control
- interrupt signals
- DMA control lines

5.3.1 DATA BUS

The local data bus is the signal path for data transfers between the host CPU and the MPC.

D<31-0>. D<31-0> is the 32-bit local data bus. Although this is a 32-bit interface, the MPC allows operation with processors using 8-, 16-, or 32-bit data busses.

NOTE:

Intel CPU architecture defines bit 0 and byte 0 as least significant. When connecting non-Intel processors to the MPC local data bus, it is important that this bit and byte ordering be maintained across the PSB. This allows agents of differing CPU types to work together in a single chassis. If byte-swapping is needed, see the discussion of the *byte enable* (BE<3-0>) signal pins.

5.3.2 ADDRESS/STATUS SIGNALS

The address/status signals select or identify all MPC operations over the local bus.

A<5-2> (Address). The address inputs select MPC registers for message and interconnect space operations. A1 and A0 are omitted to provide a consistent register address for all data bus width options. A<5-2> are qualified by \overline{RD} or \overline{WR} and therefore must be stable within the specified set-up and hold window.

MEMSEL (Memory Select). This MPC input signal tells the MPC that the current operation is a memory

reference across the PSB. \overline{MEMSEL} is qualified by \overline{RD} or \overline{WR} and therefore must be stable within the specified set-up and hold window.

NOTE:

\overline{MEMSEL} , \overline{IOSEL} , \overline{REGSEL} , \overline{IDACK} , and \overline{ODACK} are mutually exclusive. In order to be valid, no more than one should be active during the same set-up and hold window.

IOSEL (I/O Select). This input signal tells the MPC that the current operation is an I/O reference to the PSB. \overline{IOSEL} is qualified by \overline{RD} or \overline{WR} and therefore must be stable within the specified set-up and hold window.

REGSEL (Register Select). This input signal is used to identify MPC register operations. \overline{REGSEL} is qualified by \overline{RD} or \overline{WR} and therefore must be stable within the specified set-up and hold window.

LOCK. This input signal allows back-to-back operations to be performed on the PSB or local interconnect space. When the bus owner activates \overline{LOCK} , all other agents are held off the PSB or local resource until \overline{LOCK} is deactivated.

BE<3-0> (Byte Enable). These input signals, generated by the host CPU or DMA controller, validate bytes on the data bus. BE<3-0> are qualified by \overline{RD} or \overline{WR} and therefore must be stable within the specified set-up and hold window. BE<3-0> correspond to data bytes 3 through 0 on the data bus (where byte 3 is D<31-24>). For remote reference operations, only combinations supported by the IEEE 1296 specification are valid.

A 32-bit local bus requires that all byte enable and data signals are used. For 16-bit local buses, $\overline{BE1}$ and $\overline{BE2}$ are used to indicate which of the two bytes will contain valid data, and only D<15-0> are used. For 8-bit local bus operations, $\overline{BE1}$ and $\overline{BE0}$ are used to select which byte of the PSB will carry the valid data byte. This mode uses only D<7-0> (on the local bus). Note that during all read operations, the MPC drives all data lines (D<31-0>). Consecutive accesses to message FIFOs must be in ascending byte sequence 0, 1, 2, 3 in any non-overlapping combination.

Table 5-3 shows the valid byte enable combinations for both the local data bus (D<31-0>) and the PSB ($\overline{AD}<31-0>$):

Table 5-3. Valid Byte Enable Combinations

BE3	BE2	BE1	BE0	D31-24	D23-16	D15-8	D7-0	AD31-24	AD23-16	AD15-8	AD7-0
L	L	L	L	V3	V2	V1	V0	V3	V2	V1	V0
L	L	L	H	V3	V2	V1	X	V3	V2	V1	X
H	L	L	H	X	V2	V1	V0	X	V2	V1	V0
L	L	H	H	V3	V1	X	X	X	X	V3	V2
H	L	L	H	X	V2	V1	X	X	V2	V1	X
H	H	L	L	X	X	V1	V0	X	X	V1	V0
L	H	H	H	V3	X	X	X	X	X	V3	X
H	L	H	H	X	V2	X	X	X	X	X	V2
H	H	L	H	X	X	V1	X	X	X	V1	X
H	H	H	L	X	X	X	V0	X	X	X	V0
L	H	L	H	X	X	X	V0	X	X	V0	X
L	H	H	L	X	X	X	V0	X	X	X	V0

NOTES:

- L = Electrical low state (active)
- H = Electrical high state (inactive)
- Vn = Valid data bytes
- X = Active bytes with undefined data

For the 32-bit host interface, legal combinations of byte enables form *byte lanes*: the paths where valid data bytes are present during a single transfer on the local data bus (as well as in the MULTIBUS II environment). Non-Intel Microprocessors can use byte lanes to perform byte-swapping or other data manipulations in hardware. The figure below illustrates the legal byte lanes as they relate to byte enable combinations:

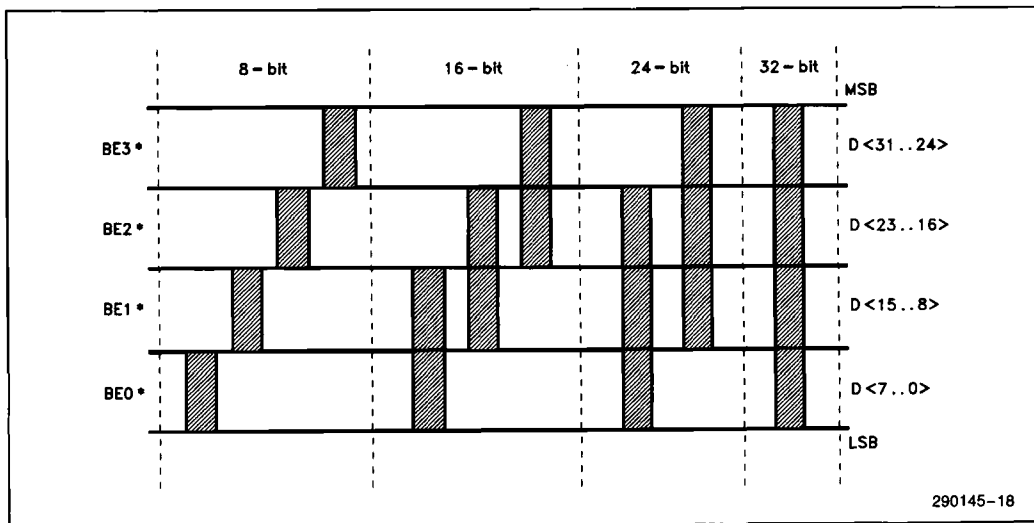

Figure 5-4. Byte Lanes

Each shaded box in Figure 5-4 represents a valid byte lane for a given combination of \overline{BE} during a single read or write operation. There are four types of byte lanes: 8-bit, 16-bit, 24-bit and 32-bit. Bit and byte ordering follow the Intel standard of bit or byte 0 as least significant. Assume that invalid byte lanes contain any value of data (i.e. non-constant). Take precautions (masking in software, etc.) to ensure that invalid data does not cause problems.

When using a DMA controller to handle solicited data transfers to/from local memory, misalignment of data in memory and resulting partial packets are handled using the \overline{BE} lines. The DMA interface of the MPC provides support by only incrementing internal pointers (or detecting completion) when the proper byte-enable signal is active. Table 5-4 shows which \overline{BE} line the MPC recognizes for partial packets:

Table 5-4. Byte Enable Usage for DMA Control

DMA Width	Bytes Remaining	Byte Enable Recognized
32-bit	>3	$\overline{BE3}$
32-bit	3	$\overline{BE2}$
32-bit	2	$\overline{BE1}$
32-bit	1	$\overline{BE0}$
16-bit	>1	$\overline{BE1}$
16-bit	1	$\overline{BE0}$
8-bit	>0	$\overline{BE0}$

5.3.3 TRANSFER CONTROL SIGNALS

Transfer operation control to the MPC over the local bus is provided by two command signals and a wait signal. This handshake provides fully interlocked (two-sided handshake) operation.

\overline{RD} (Read). This input signal starts a read operation. \overline{RD} must transition cleanly, since it is used to qualify other signals in the read operation.

\overline{WR} (Write). This input signal starts a write operation. \overline{WR} must transition cleanly, since it is used to qualify other signals in the write operation.

\overline{WAIT} . \overline{WAIT} is an MPC output signal used to extend a transfer operation. The signal will be used by the MPC for all accesses that require synchronization to another resource. It is activated when a command goes active and deactivated when the operation is completed.

5.3.4 INTERRUPT SIGNALS

Interrupt signals are used to inform the host CPU that the MPC requires service. The MPC generates two signals: one for message operations and one for reference errors.

MINT (Message Interrupt). The MINT output signal is used for all message-related signaling to the host CPU. This includes the arrival of an unsolicited message, the availability of the transmit FIFO, the completion of a solicited transfer, and an error-on message transfer.

EINT (Error Interrupt). The EINT output signal is used to signal all errors related to memory, I/O, or interconnect space operations. Internal registers in the MPC provide exact details of the error via interconnect space.

5.3.5 DMA CONTROL SIGNALS

The MPC provides four DMA control signals that connect with an external DMA controller.

ODREQ (Output Channel DMA Request). ODREQ is an output signal that enables DMA transfers to the MPC (i.e., output to the PSB). This signal behaves as a normal DMA request line during solicited message output operations. ODREQ is activated during the transfer phase of a solicited message operation when the solicited output FIFO is empty. The DMA controller responds to ODREQ by moving data from local memory to the FIFO for transfer to a receiving agent on the PSB.

IDREQ (Input Channel DMA Request). IDREQ is an output signal that enables DMA transfers from the MPC (i.e. input from the PSB). This signal behaves as a normal DMA request line during solicited message input operations. IDREQ is activated during the transfer phase of a solicited message operation when the solicited input FIFO is full. The DMA controller responds to ODREQ by moving data from the FIFO to local memory. When the FIFO is emptied, IDREQ is deactivated.

\overline{ODACK} (Output Channel DMA Acknowledge). \overline{ODACK} is generated by the DMA controller in response to an output channel DMA request. \overline{ODACK} is qualified by \overline{RD} or \overline{WR} and therefore must be stable within the specified set-up and hold window.

NOTE:

\overline{MEMSEL} , \overline{IOSEL} , \overline{REGSEL} , \overline{IDACK} , and \overline{ODACK} are mutually exclusive. In order to be valid, no more than one should be active during the same set-up and hold window.

\overline{IDACK} (Input Channel DMA Acknowledge). \overline{IDACK} is generated by the DMA controller in response to an input channel DMA request. \overline{IDACK} is qualified by \overline{RD} or \overline{WR} and therefore must be stable within the specified set-up and hold window.

5.4 Interconnect Bus Signals

Brief descriptions of the interconnect bus signal pins are given here. For more information on using the interconnect microcontroller, see the *MPC User's Manual*, Chapter 5, "Interconnect Programming" (Order number 176526-002).

IAD<7-0> (Interconnect Address/Data). IAD<7-0> is an 8-bit, bidirectional, multiplexed address and data bus intended to interface directly to a microcontroller. In addition to the MPC, other interconnect accessible local resources can be connected to this bus.

$\overline{\text{IREQ}}$ (Interconnect Request). The MPC asserts this output signal when an interconnect operation has been requested from either the local bus or the PSB. The MPC asserts $\overline{\text{IREQ}}$ to the interconnect microcontroller at different times for read and write operations. For a read operation, $\overline{\text{IREQ}}$ is asserted immediately after detecting an address match between the requested address and an internal register. For a write operation, $\overline{\text{IREQ}}$ is delayed until valid data is

available (i.e., $\overline{\text{BSC3}}$ is asserted). In either case, if the local bus interface has locked the local interconnect space, $\overline{\text{IREQ}}$ is inhibited.

IAST (Interconnect Address Strobe). IAST is a signal from the microcontroller that tells the MPC that a valid address is on the interconnect bus. IAST may be directly connected to the ALE (Address Latch Enable or equivalent) output of most microcontrollers. IAST must provide clean transitions.

$\overline{\text{IRD}}$ (Interconnect Bus Read). The microcontroller asserts $\overline{\text{IRD}}$ to perform a read operation to one of the MPC interconnect interface registers. $\overline{\text{IRD}}$ must provide clean transitions.

NOTE:

When $\overline{\text{IRD}}$ and $\overline{\text{IWR}}$ are activated at the same time, all MPC outputs are disabled. Use this feature to disable the MPC in board test applications.

$\overline{\text{IWR}}$ (Interconnect Write). The microcontroller asserts $\overline{\text{IWR}}$ to perform a write operation to one of the MPC interconnect interface registers. $\overline{\text{IWR}}$ must provide clean transitions.

6.0 Package Dimensions

The MPC 82389 is packaged in a 149-pin Ceramic Pin Grid Array (PGA). The pins are arranged 0.100 inch (2.54 mm) center-to-center, in a 15 x 15 matrix. Please refer to Figure 6-3 for case outlines.

A wide variety of sockets are available including the zero-insertion force socket for prototyping.

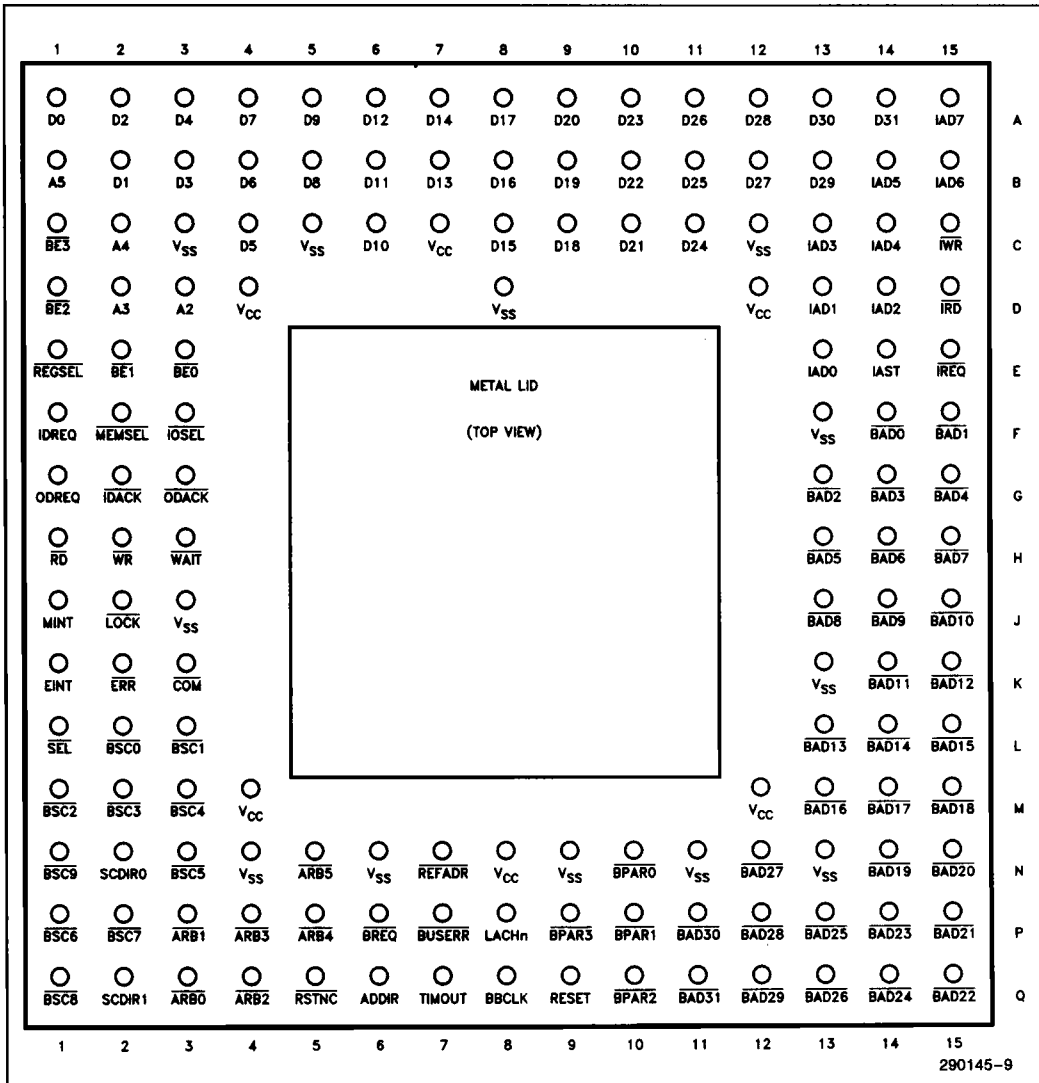

Figure 6-1. MPC 82389 Pinout—View from Top Side

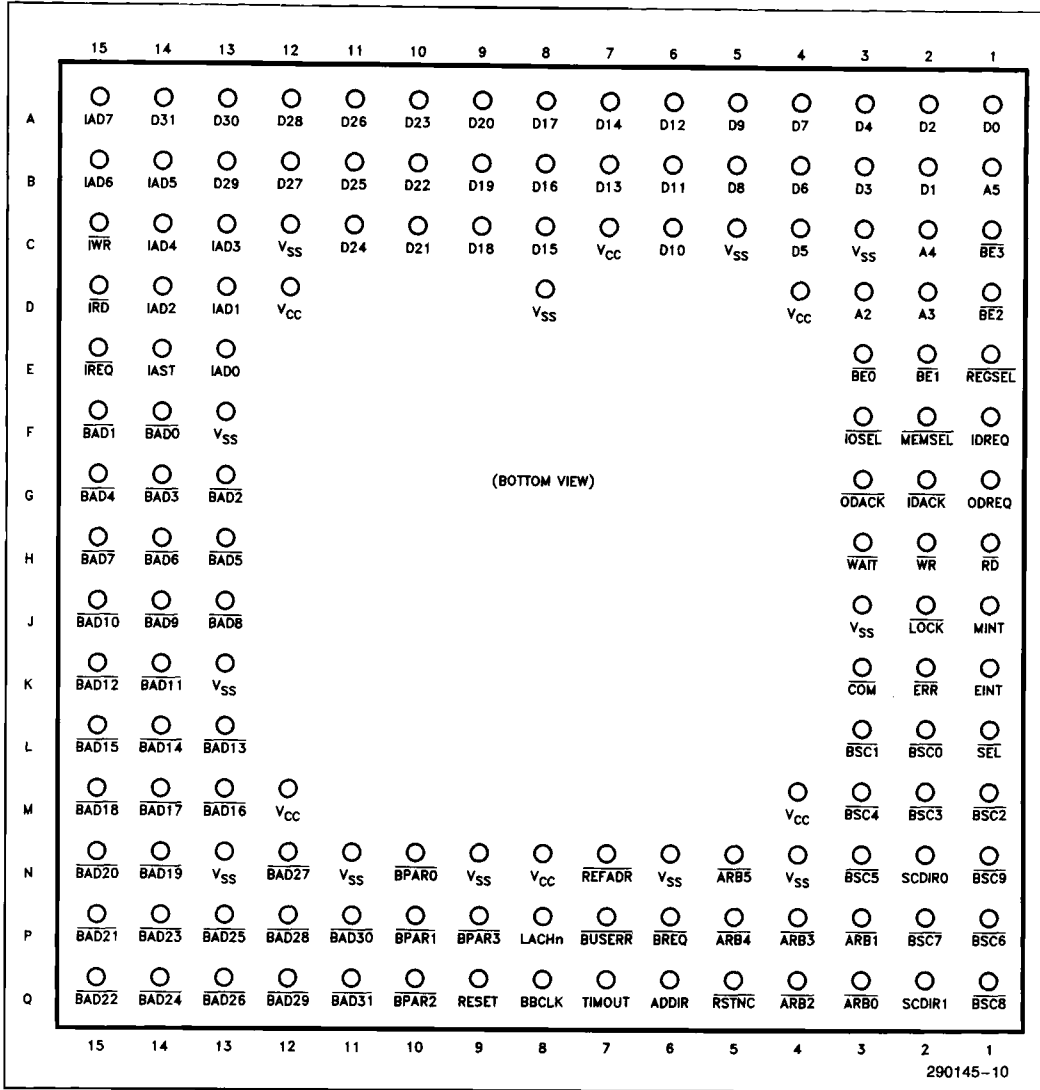

Figure 6-2. MPC 82389 Pinout—View from Pin Side

Table 6-1. MPC Signal Summary

Mnemonic	Type	Pin #	Mnemonic	Type	Pin #	Mnemonic	Type	Pin #
V _{CC}		D4	REFADR	O	N7	IAST	I	E14
A5	I	B1	ADDIR	O	Q6	IRD	I	D15
A4	I	C2	BPAR3	I/O	P9	IWR	I	C15
A3	I	D2	BAD31	I/O	Q11	IAD7	I/O	A15
A2	I	D3	BAD30	I/O	P11	IAD6	I/O	B15
BE3	I	C1	BAD29	I/O	Q12	IAD5	I/O	B14
BE2	I	D1	BAD28	I/O	P12	IAD4	I/O	C14
BE1	I	E2	BAD27	I/O	N12	IAD3	I/O	C13
BE0	I	E3	BAD26	I/O	Q13	IAD2	I/O	D14
IOSEL	I	F3	BAD25	I/O	P13	IAD1	I/O	D13
MEMSEL	I	F2	BAD24	I/O	Q14	IAD0	I/O	E13
REGSEL	I	E1	BAD23	I/O	P14	V _{CC}		D12
IDACK	I	G2	BAD22	I/O	Q15	V _{SS}		C12
ODACK	I	G3	BAD21	I/O	P15	D31	I/O	A14
IDREQ	O	F1	BAD20	I/O	N15	D30	I/O	A13
ODREQ	O	G1	BAD19	I/O	N14	D29	I/O	B13
WR	I	H2	BAD18	I/O	M15	D28	I/O	A12
RD	I	H1	BAD17	I/O	M14	D27	I/O	B12
WAIT	O	H3	BAD16	I/O	M13	D26	I/O	A11
V _{SS}		J3	BAD15	I/O	L15	D25	I/O	B11
MINT	O	J1	BAD14	I/O	L14	D24	I/O	C11
EINT	O	K1	BAD13	I/O	L13	D23	I/O	A10
LOCK	I	J2	BAD12	I/O	K15	D22	I/O	B10
ERR	I	K2	BAD11	I/O	K14	D21	I/O	C10
SEL	O	L1	BAD10	I/O	J15	D20	I/O	A9
COM	I	K3	BAD9	I/O	J14	D19	I/O	B9
BSC9	I/O	N1	BAD8	I/O	J13	D18	I/O	C9
BSC8	I/O	Q1	BAD7	I/O	H15	D17	I/O	A8
BSC7	I/O	P2	BAD6	I/O	H14	D16	I/O	B8
BSC6	I/O	P1	BAD5	I/O	H13	D15	I/O	C8
BSC5	I/O	N3	BAD4	I/O	G15	D14	I/O	A7
BSC4	I/O	M3	BAD3	I/O	G14	D13	I/O	B7
ARB3	I/O, OC	P4	V _{SS}		N13	D2	I/O	A2

Table 6-1. MPC Signal Summary (Continued)

Mnemonic	Type	Pin #	Mnemonic	Type	Pin #	Mnemonic	Type	Pin #
BSC3	I/O	M2	BAD2	I/O	G13	D12	I/O	A6
BSC2	I/O	M1	BAD1	I/O	F15	D11	I/O	B6
BSC1	I/O	L3	BAD0	I/O	F14	D10	I/O	C6
BSC0	I/O	L2	BPAR2	I/O	Q10	D9	I/O	A5
SCDIR1	O	Q2	BPAR1	I/O	P10	D8	I/O	B5
SCDIR0	O	N2	BPAR0	I/O	N10	D7	I/O	A4
V _{CC}		M4	V _{CC}		N8	D6	I/O	B4
V _{SS}		N4	V _{SS}		N9	D5	I/O	C4
ARB5	I/O, OC	N5	V _{SS}		N11	D4	I/O	A3
ARB4	I/O, OC	P5	V _{CC}		M12	D3	I/O	B3
ARB2	I/O, OC	Q4	V _{SS}		F13	D1	I/O	B2
ARB1	I/O, OC	P3	V _{SS}		K13	D0	I/O	A1
ARB0	I/O, OC	Q3	BBCLK	I	Q8	V _{CC}		C7
V _{SS}		N6	LACHn	I	P8	V _{SS}		D8
BREQ	I/O, OC	P6	RESET	I	Q9	V _{SS}		C5
TIMOUT	I/O	Q7	RSTNC	I/O, OC	Q5	BUSERR	I/O, OC	P7
IREQ	O	E15	V _{SS}		C3			

NOTES:

I = input

O = output

I/O = input/output

OC = open-collector

* = active-low

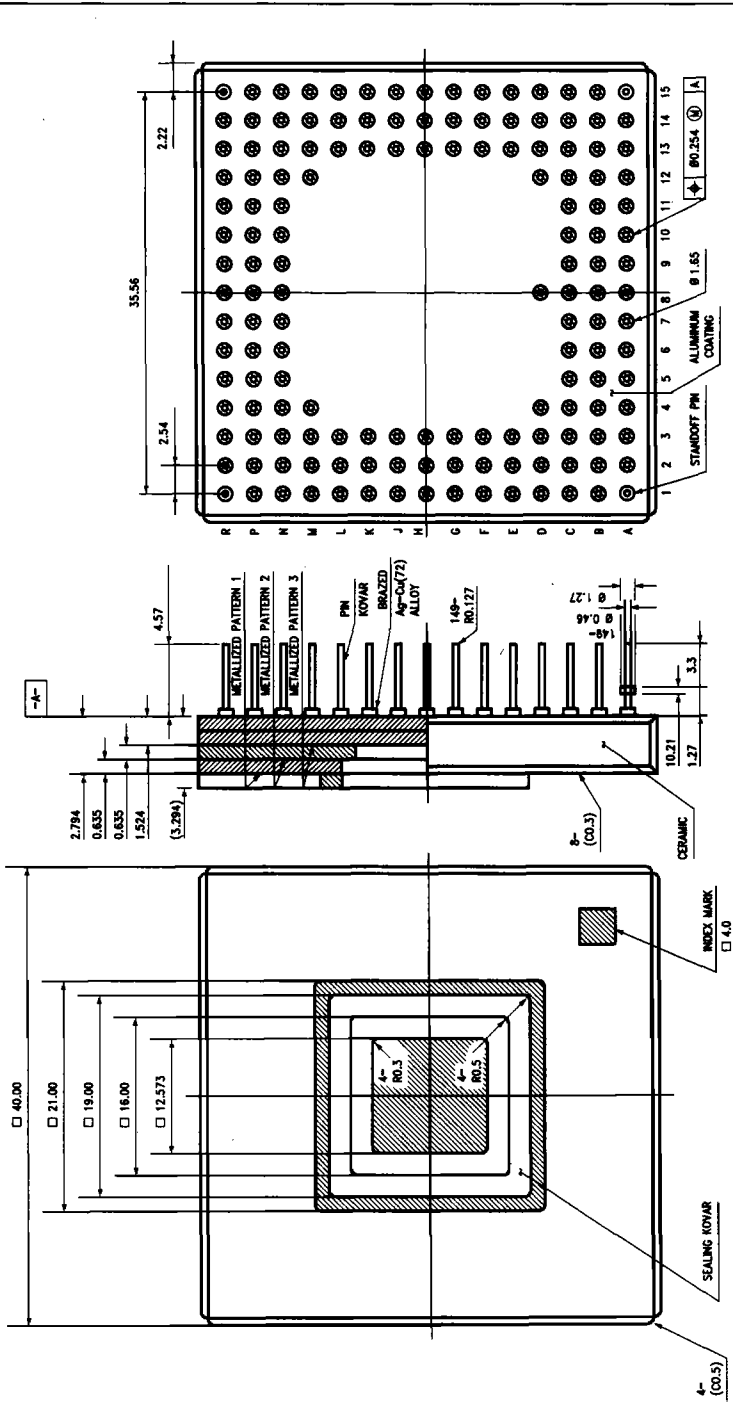

290145-11

NOTE:
Dimensions in mm.

Figure 6-3. 149-Pin PGA Package Dimensions

7.0 MPC 82389 ELECTRICAL DATA

This section provides detailed A.C. and D.C. specifications for the MPC 82389.

7.1 Maximum Ratings

Operating Temperature

(Under Bias) -10°C to +85°C

Storage Temperature -65°C to +150°C

Voltage on Any Pin -0.5V to $V_{CC} + 0.5V$

Power Dissipation 2.5W

NOTE:

Stresses above those listed may cause permanent damage to the device. This is a stress rating only and functional operation at these or any other conditions above those listed in the operational sections of this specification is not implied.

Exposure to absolute maximum rating conditions for extended periods may affect device reliability. Although the MPC 82389 contains protective circuitry to resist damage from static electrical discharges, always take precautions against high static voltages or electric fields.

7.2 D.C. Specifications $V_{CC} = 5.0V \pm 5\%$, $T_A = 0^\circ C$ to $+70^\circ C$

Table 7-1. D.C. Specifications

Symbol	Parameter	Min	Max	Units	Test Conditions
V_{IL}	Input Low Voltage	-0.5	0.8	V	
V_{IH}	Input High Voltage	2.0	$V_{CC} + 0.5$	V	
V_{OL1}	Output Low Voltage		0.45	V	I_{OL} Max
V_{OL2}	Output Low Voltage Open Collector		0.55	V	I_{OL} Max
V_{OH}	Output High Voltage	2.4		V	I_{OH} Max
I_{CC}	Power Supply Current		400	mA	
I_L	Input Leakage Current		± 10	μA	$0V \leq V_{IN} \leq V_{CC}$
I_{L1}	Open Collector Leakage Current		± 100	μA	$0.4V \leq V_{IN} \leq 2.4V$
			± 400	μA	$0V \leq V_{IN} \leq V_{CC}$
I_{L2}	BBCLK Input Leakage Current		± 100	μA	$0V \leq V_{IN} \leq V_{CC}$
I_{OL}	Output Low Current	4.0		mA	$V_{OL} = 0.45V$
I_{OL1}	Open Collector Output Low Current	60.0		mA	$V_{OL} = 0.55V$
I_{OL2}	ADDIR and REFADR Output Low Current	8.0		mA	$V_{OL} = 0.45V$
I_{OH}	Output High Current	-1.0		mA	$V_{OH} = 2.4V$
C_I	Input Capacitance		10	pF	$f_C = 1$ MHz, 25°C (Note 1)
C_{IO}	I/O Capacitance		20	pF	$f_C = 1$ MHz, 25°C (Note 1)
C_{CLK}	Clock Input Capacitance		15	pF	$f_C = 1$ MHz, 25°C (Note 1)
C_{OC}	Open Collector Capacitance		20	pF	$f_C = 1$ MHz, 25°C (Note 1)

NOTE:

1. Sampled only, not 100% tested.

7.3 A.C. Specifications

The A.C. specifications for the MPC 82389 are specified in Tables 7-2, 7-3 and 7-4 and Figures 7-2, 7-3, 7-4 and 7-5. Figure 7-1 specifies the test points for measuring the A.C. parameters. Table 7-2 and Figures 7-2 and 7-3 specify the A.C. parameters for the host CPU bus. Table 7-3 and Figure 7-4 specify the A.C. parameters for the interconnect bus. Table 7-4 and Figure 7-5 specify the A.C. parameters for the PSB. Figure 7-6 defines the test load for the A.C. specifications.

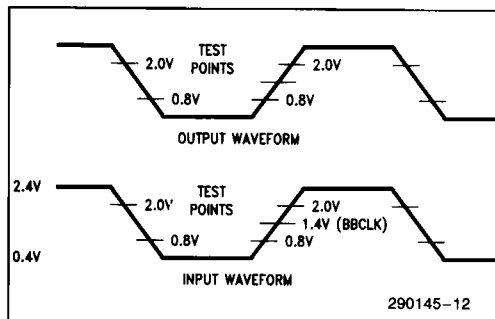

Figure 7-1. A.C. Test Waveforms

Table 7-2. Host CPU Bus A.C. Specifications ($V_{CC} = 5V \pm 5\%$, $T_A = 0^\circ C$ to $+70^\circ C$)

Symbol	Parameter	Min	Max	Units	Test Conditions
t_1	Address and \overline{BE} Setup to Command Active	20		ns	
	Select and DACK Setup to Command Active	18		ns	
t_2	Address, \overline{BE} , Select and DACK Hold from Command Active	5		ns	
t_3	Time between Commands	24		ns	
t_4	Command Inactive to Read Data Disable (Note 5)		15	ns	
t_5	Read Data Hold from Command Inactive	3		ns	
t_6	Read Data Enable from Command Active	0		ns	
t_7	\overline{WAIT} Active from Command Active		20	ns	$C_L = 50$ pF
t_8	Command Inactive from \overline{WAIT} Inactive	0		ns	
t_9	\overline{WAIT} Inactive to Read Data Valid		25	ns	$C_L = 90$ pF
t_{10}	Command Active to Write Data Valid		200	ns	
t_{11}	Write Data Hold from \overline{WAIT} Inactive	0		ns	
t_{12}	Command Active to \overline{LOCK} Active (Note 1)		100	ns	
t_{13}	\overline{LOCK} Hold from \overline{WAIT} Inactive (Note 2)	0		ns	
t_{14}	Command Active Time	42		ns	
t_{15}	Read Data Valid from Command Active		42	ns	$C_L = 90$ pF
t_{16}	Write Data Setup to Command Inactive			ns	
	—Registers —DMA	20 20		ns ns	
t_{17}	Write Data Hold from Command Inactive	3		ns	
t_{18}	Command Active to MINT or DREQ Inactive (Notes 3, 4)		42	ns	$C_L = 50$ pF
t_{19}	Command Active to DREQ Inactive (Note 4)		25	ns	$C_L = 50$ pF

NOTES:

1. Required to guarantee locking of resource.
2. Required to guarantee resource remains locked.
3. MINT deassertion only if no other sources are pending.
4. For DREQ inactive timing, t_{19} applies to a normal last transfer deassert condition and t_{18} to an error deassert condition.
5. Disable condition occurs when the output current becomes less than the input leakage specification.

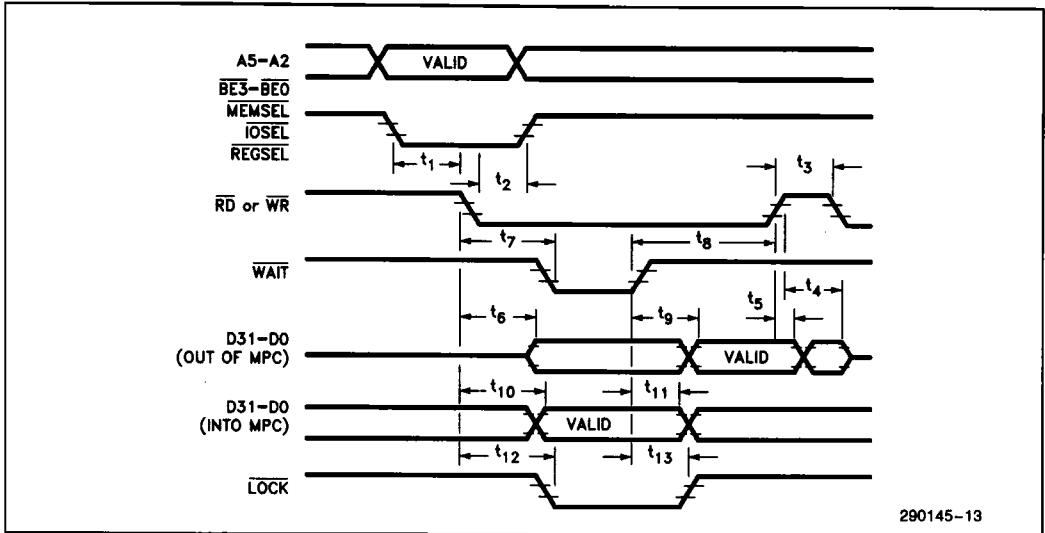

290145-13

Figure 7-2. Host CPU Interface Reference Operation Timing

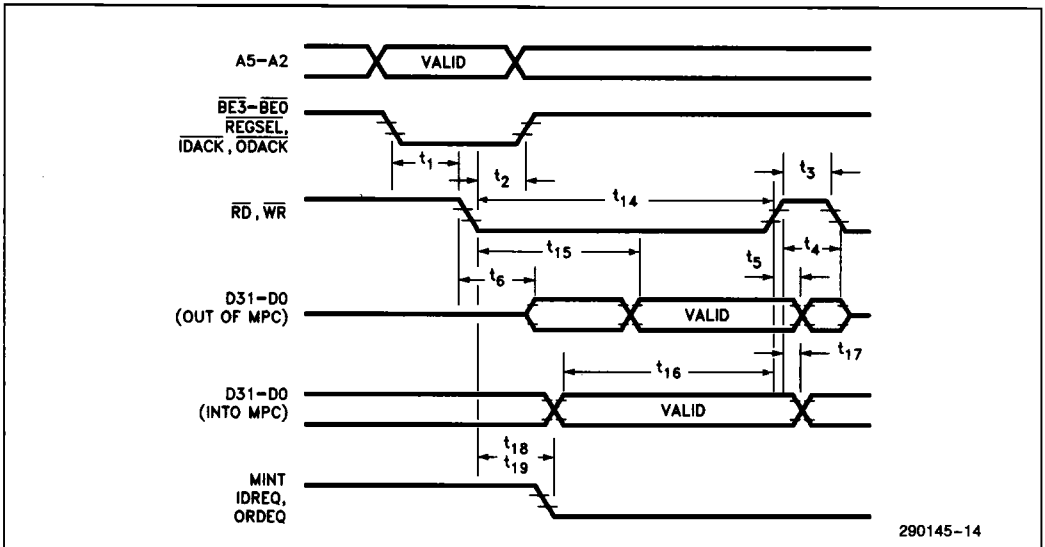

290145-14

Figure 7-3. Host CPU Interface Register and DMA Operation Timing

Table 7-3. Interconnect Bus A.C. Specifications ($V_{CC} = 5V \pm 5\%$, $T_A = 0^\circ C$ to $+70^\circ C$)

Symbol	Parameter	Min	Max	Units	Test Conditions
t_{31}	IAST Active Time	85		ns	
t_{32}	Command Active Time	250		ns	
t_{33}	Command Inactive to IAST Active	25		ns	
t_{33A}	IAST Inactive to Command Active	120		ns	
t_{34}	Address Setup to IAST Inactive	40		ns	
t_{35}	Address Hold from IAST Inactive	20		ns	
t_{36}	Write Data Setup to Command Inactive	120		ns	
t_{37}	Write Data Hold from Command Inactive	5		ns	
t_{38}	Read Data Enable from Command Active	0		ns	
t_{39}	Read Data Valid from Command Active		120	ns	$C_L = 150$ pF
t_{40}	Read Data Hold from Command Inactive	0		ns	
t_{41}	Read Data Disable from Command Inactive (Note 2)		30	ns	
t_{42}	EINT, \overline{IREQ} Inactive from Command Active (Note 1)		100	ns	$C_L = 150$ pF

NOTES:

1. EINT inactive only on write to error register. \overline{IREQ} inactive only on write to arbitration register.
2. Disable condition occurs when the output current becomes less than the input leakage specification.

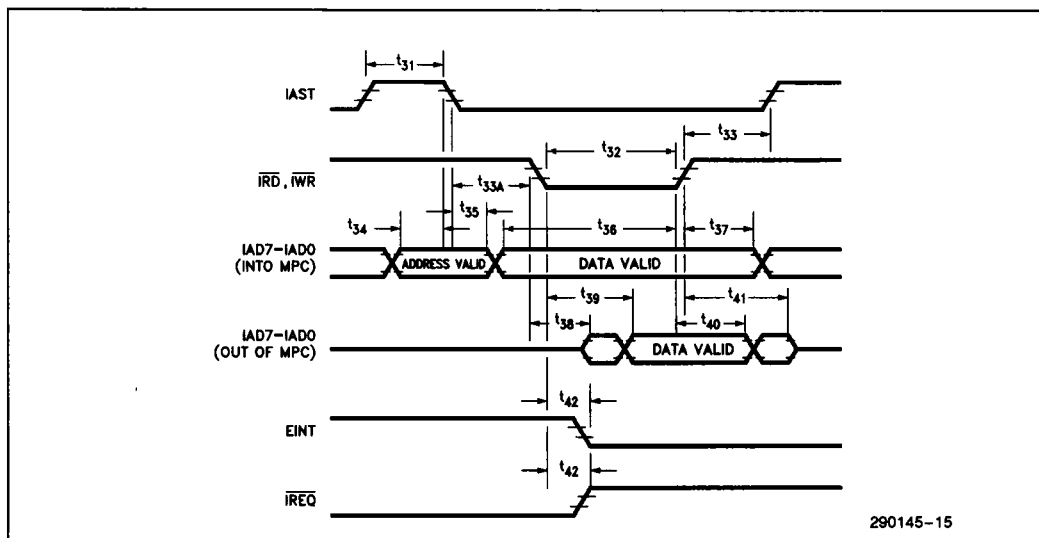

Figure 7-4. Interconnect Bus Timing

Table 7-4. PSB Interface A.C. Specifications ($V_{CC} = 5V \pm 5\%$, $T_A = 0^\circ C$ to $+70^\circ C$)

Symbol	Parameter	Min	Max	Units	Test Conditions
t_{CP}	Clock Period	99.9		ns	
* t_{CL}	\overline{BCLK} Low Time	40		ns	
* t_{CH}	\overline{BCLK} High Time	40		ns	
t_{BCL}	BBCLK Low Time	38		ns	
t_{BCH}	BBCLK High Time	38		ns	
t_{RB}	\overline{BCLK} Rise Time	1	5	ns	
t_{FB}	\overline{BCLK} Fall Time	1	2	ns	
t_R	BBCLK Rise Time	0.5	1	ns	
t_F	BBCLK Fall Time	0.5	1	ns	
t_{SK}	\overline{BCLK} to BBCLK Skew (Note 1)	-0.5	4.0	ns	
t_{CD}	Clock to Output Delay \overline{BREQ} , \overline{BUSERR} , \overline{RSTNC} (Note 2) $\overline{ARB5}$ – $\overline{ARB0}$ (Notes 2, 3) $\overline{BAD31}$ – $\overline{BAD0}$, $\overline{BSC7}$ – $\overline{BSC0}$ $\overline{BPAR3}$ – $\overline{BPAR0}$, $\overline{BSC9}$, $\overline{BSC8}$ SCDIR0, SCDIR1 (H to L) (L to H) ADDR (L to H) (H to L) \overline{REFADR} SEL		36 36 29 29 19 21 21 27 29 29	ns ns ns ns ns ns ns ns ns ns	$C_L = 500$ pF $C_L = 500$ pF $C_L = 75$ pF $C_L = 50$ pF $C_L = 25$ pF $C_L = 25$ pF $C_L = 50$ pF $C_L = 50$ pF $C_L = 75$ pF $C_L = 50$ pF
t_H	Hold Time from Clock \overline{BREQ} , \overline{BUSERR} , \overline{RSTNC} $\overline{ARB5}$ – $\overline{ARB0}$ (Note 3) $\overline{BAD31}$ – $\overline{BAD0}$, $\overline{BPAR3}$ – $\overline{BPAR0}$ $\overline{BSC9}$ – $\overline{BSC0}$ SCDIR0, SCDIR1 ADDR \overline{REFADR} SEL	6.5 6.5 5.0 4.0 4.0 5.0 4.0 4.0		ns ns ns ns ns ns ns ns	$C_L = 25$ pF $C_L = 25$ pF $C_L = 15$ pF $C_L = 15$ pF $C_L = 15$ pF $C_L = 25$ pF $C_L = 25$ pF $C_L = 15$ pF
t_{ON}	Turn On Delay from Clock (Note 4) \overline{BREQ} , \overline{BUSERR} , \overline{RSTNC} $\overline{ARB5}$ – $\overline{ARB0}$ (Note 1) $\overline{BAD31}$ – $\overline{BAD0}$, $\overline{BPAR3}$ – $\overline{BPAR0}$ $\overline{BSC9}$ – $\overline{BSC0}$	6.5 6.5 5.0 4.0		ns ns ns ns	
t_{OFF}	Turn Off Delay from Clock (Note 5) \overline{BREQ} , \overline{BUSERR} , \overline{RSTNC} $\overline{ARB5}$ – $\overline{ARB0}$ (Note 3) $\overline{BAD31}$ – $\overline{BAD0}$, $\overline{BPAR3}$ – $\overline{BPAR0}$ $\overline{BSC9}$ – $\overline{BSC0}$		36 36 29 29	ns ns ns ns	

* t_{CL} and t_{CH} are MULTIBUS II specifications.

Table 7-4. PSB Interface A.C. Specifications ($V_{CC} = 5V \pm 5\%$, $T_A = 0^{\circ}C$ to $+70^{\circ}C$) (Continued)

Symbol	Parameter	Min	Max	Units	Test Conditions
t_{SU}	Input Setup Time to Clock				
	\overline{BREQ} , \overline{BUSERR} , \overline{RSTNC}	22		ns	
	$\overline{ARB5}$ – $\overline{ARB0}$ (Note 3)	40		ns	
	$\overline{BAD31}$ – $\overline{BAD0}$, $\overline{BPAR3}$ – $\overline{BPAR0}$	24		ns	
	$\overline{BSC9}$ – $\overline{BSC0}$	24		ns	
	TIMEOUT, LACHn, RESET	24		ns	
	\overline{COM} , \overline{ERR}	40		ns	
t_{IH}	Input Hold Time from Clock				
	\overline{BREQ} , \overline{BUSERR} , \overline{RSTNC}	0		ns	
	$\overline{ARB5}$ – $\overline{ARB0}$ (Note 3)	0		ns	
	$\overline{BAD31}$ – $\overline{BAD0}$, $\overline{BPAR3}$ – $\overline{BPAR0}$	3		ns	
	$\overline{BSC9}$ – $\overline{BSC0}$	2		ns	
	TIMEOUT, LACHn, RESET	2		ns	
	\overline{COM} , \overline{ERR}	3		ns	

NOTES:

1. The clock timings are provided to reference the MPC specification to the PSB specifications. These specifications assume a 74AS1804 or equivalent buffer.
2. The 500 pF load is a distributed load as defined in the PSB specification. The open drain signals are designed such that the output delay and bus loss meets the PSB specification requirement.
3. The $\overline{ARB5}$ – $\overline{ARB0}$ signal timings are with respect to the first and last clock of the arbitration period. Details can be found in the PSB specification. Also, the arbitration logic has been designed to meet the loop delay specification accounting for the full path of input to output plus bus loss.
4. Minimum turn on times are measured the same way as hold times. Specifically, the logic level driven by another device on the previous clock cycle must not be disturbed.
5. Maximum turn off times are measured to the condition where the output leakage current becomes less than the input leakage specification.
6. All stated capacitances are based on design requirements. Production test limitations may require some parameters to be tested under a different condition.

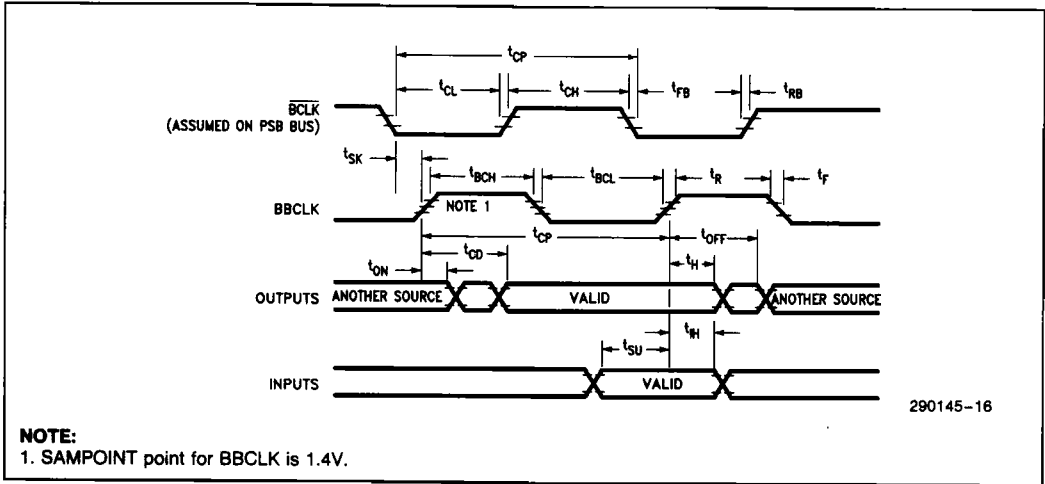

Figure 7-5. PSB Interface Timing

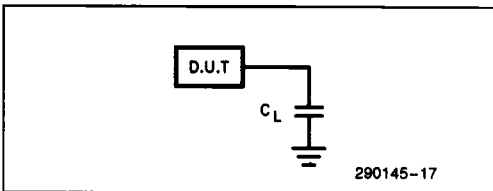

Figure 7-6. A.C. Test Load

8.0 REFERENCE DOCUMENTS

Part Number	Title Description
176526-002	MPC User's Manual
146077	MULTIBUS II Architecture Specifications
149299	Interconnect Interface Specifications
149300	MULTIBUS II MPC External Product Specifications
149247	MULTIBUS II Transport Protocol Specifications
459706-001	CSM/002 Hardware Reference Manual