

# Things Air<sup>®</sup>

TA3200R1D IoT Wi-Fi<sup>®</sup> Module

Created for the Internet of Things(IoT)

## TA3200R1D Data Sheet v1.04

<b>Date</b>	<b>Revision</b>	<b>Description</b>
<b>May. 11th 2015</b>	<b>V1.0</b>	<b>Initial Release</b>
<b>Aug. 4th 2015</b>	<b>V1.01</b>	<b>Update PCB Layout for Package</b>
<b>Aug. 10th 2015</b>	<b>V1.02</b>	<b>Update PCB Layout for Package</b>
<b>Aug. 13th 2015</b>	<b>V1.03</b>	<b>Update PCB Layout for Package</b>
<b>Oct. 9th 2015</b>	<b>V1.04</b>	<b>Update Industrial Grade</b>

## Table of Contents

<b>1 Device Overview</b> .....	- 1 -
<b>1.1 Features</b> .....	- 1 -
<b>1.2 Applications</b> .....	- 2 -
<b>1.3 Descriptions</b> .....	- 2 -
<b>1.4 Functional Block Diagram</b> .....	- 2 -
<b>2 TA3200R1D Terminal Overview</b> .....	- 4 -
<b>2.1 TA3200R1D Terminal Diagram</b> .....	- 4 -
<b>2.2 TA3200R1D Terminal Descriptions</b> .....	- 5 -
<b>3 Specifications</b> .....	- 6 -
<b>3.1 Absolute Maximum Ratings</b> .....	- 6 -
<b>3.2 Handling Ratings</b> .....	- 6 -
<b>3.3 Recommended Operating Conditions</b> .....	- 6 -
<b>3.3.1 Reset Requirement</b> .....	- 7 -
<b>3.3.2 Current Consumption</b> .....	- 7 -
<b>4 Application Information</b> .....	- 8 -
<b>4.1 Reference Schematics</b> .....	- 8 -
<b>4.2 Antenna Style Selection</b> .....	- 9 -
<b>5 Mechanical Packaging</b> .....	- 10 -
<b>5.1 Mechanical Drawing</b> .....	- 10 -
<b>5.2 Recommended PCB Layout for Package</b> .....	- 11 -
<b>6 Environmental Requirements and Specifications</b> .....	- 12 -
<b>6.1 Temperature</b> .....	- 12 -
<b>6.1.1 PCB Bending</b> .....	- 12 -
<b>6.2 Handling Environment</b> .....	- 12 -
<b>6.2.1 ESD</b> .....	- 12 -
<b>6.2.2 Terminals</b> .....	- 12 -
<b>6.2.3 Falling</b> .....	- 12 -
<b>6.3 Storage Condition</b> .....	- 12 -
<b>6.3.1 Moisture Barrier Bag Before Opened</b> .....	- 12 -
<b>6.3.2 Moisture Barrier Bag Open</b> .....	- 12 -
<b>6.4 Baking Conditions</b> .....	- 12 -
<b>6.5 Soldering and Reflow Condition</b> .....	- 12 -
<b>Contact details</b> .....	- 13 -

## 1 Device Overview

### 1.1 Features

- Wi-Fi Microcontroller Module
  - ARM Cortex-M4 Microcontroller with 802.11 b/g/n Wi-Fi Network Processor
  - Embedded Wi-Fi Driver, Supplicant, and TCP/IP v4 Networking Stack with Industry Standard BSD Socket APIs
  - Hardware Crypto Engine for TLS(SSL) Internet Security
  - Advanced Low-Power Wi-Fi Modes
  - SmartConfig Technology, WPS, and AP Mode to Configure Headless Device to Connect to the Wi-Fi Network
  - Secure Device Option with On-Chip 128-Bit Secret Key and Secure Boot
- Applications Microcontroller Subsystem
  - ARM Cortex-M4 Core at 80 MHz
  - Embedded Memory Options
    - Onboard Flash
    - RAM(up to 256KB)
    - Peripheral Drivers in ROM
    - 8Mbit-Onboard flash
  - Hardware Crypto Engine for Advanced Hardware Security Including
    - AES, DES, and 3DES
    - SHA and MD5
    - CRC and Checksum
  - 8-Bit, Fast, Parallel Camera Interface
  - 1 Multichannel Audio Serial Port (McASP) Interface with Support for I2S Format
  - 1 SD (MMC) Interface
  - 32-Channel Micro Direct Memory Access( $\mu$ DMA)
  - 2 Universal Asynchronous Receivers/Transmitters(UARTs)
  - 2 Serial Peripheral Interfaces(SPIs)
  - 1 Inter-integrated Circuit(I<sup>2</sup>C)
  - 4 General-Purpose Timers
  - 16-Bit Pulse-Width Modulation (PWM) Mode
  - 1 Watchdog Timer Module
  - 4-Channel 12-Bit Analog-to-Digital Converters(ADCs)
  - Up to 30 Individually Programmable GPIO Pins
- Wi-Fi Network Processor Subsystem
  - 802.11b/g/n Radio, Baseband, and Medium Access Control
  - TCP/IP Stack
    - 8 Simultaneous TCP, UDP, or RAW Sockets
    - 2 Simultaneous TLS v1.2 or SSL 3.0 Sockets
  - Powerful Crypto Engine for Fast, Secured WLAN Connections with 256-Bit Encryption
  - Station, Access Point, and Wi-Fi Direct Modes
  - WPA2 Personal and Enterprise Security
  - SimpleLink Connection Manager for Managing Wi-Fi Security States
  - TX Power
    - 17dBm at 1 DSSS
    - 17.25dBm at 11 CCK
    - 13.5dBm at 54 OFDM
  - RX Sensitivity
    - -94.7dBm at 1 DSSS
    - -87dBm at 11 CCK
    - -73dBm at 54 OFDM
  - Application Throughput
    - UDP: 16Mbps
    - TCP: 12Mbps
- Power-Management Subsystem
  - Integrated DC-DC Converter with a Wide-Supply Voltage:
    - VBAT:2.3 to 3.6V
  - Low-Power Consumption at 3.6V
    - Hibernate with Real-Time Clock(RTC):28  $\mu$  A
    - Low-Power Deep Sleep: <275  $\mu$  A
    - Idle Connected: 0.875mA@DTIM=1
    - RX Traffic:54mA@54OFDM
    - TX Traffic: 223mA@54OFDM
  - Built-in Clock Source
    - 40.0-MHz Crystal with Internal Oscillator
    - 32.768-kHz Crystal(RTC)
- Package and Operating Conditions
  - 1.27-mm Pitch, 44-Terminal, 18.22-mm  $\times$  26.65 mm Stamp Package for Easy Assembly and Low-Cost PCB Design
  - Operating Temperature Range: -40  $^{\circ}$ C to +85  $^{\circ}$ C

## 1.2 Applications

- Internet of Things (IoT)
- Cloud Connectivity
- Home Automation
- Home Appliances
- Access Control
- Security Systems
- Smart Energy
- Internet Gateway
- Industrial Control
- Smart Plug and Metering
- Wireless Audio
- IP Network Sensor Nodes
- Wearables

## 1.3 Descriptions

The TA3200R1D module is the second-generation series of modules in the SimpleLink family and consists of an applications microcontroller unit (MCU), Wi-Fi network processor, and a power-management subsystem. The module comes integrated with all required components including on-board flash, clocks, and RF filter for easy hardware integration and quick time-to-market.

The applications MCU subsystem contains an industry-standard ARM Cortex-M4 core running at 80MHz. The TA3200R1D module supports a wide variety of rich peripherals, including fast parallel camera of embedded RAM memory options, with peripheral drivers in ROM memory. The series also includes a secure device with on-chip 128-bit secret key supporting secure boot as well as applications and user data encryption.

The TA3200R1D module also features a Wi-Fi network processor subsystem which contains a dedicated ARM Cortex-M3 MCU to completely offload the applications MCU. This subsystem includes 802.11 b/g/n radio, baseband, and medium access control with a powerful crypto engine for fast secured WLAN and internet connections with 256-bit encryption. The TA3200R1D module supports station, access point, and Wi-Fi Direct modes. The TA3200R1D module also supports WPA2 personal and enterprise security and WPS 2.0. The Wi-Fi network processor includes an embedded IPv4 TCP/IP stack.

The power-management subsystem includes an integrated DC-DC converter with support for a wide range of supply voltages. This subsystem enables low-power consumption modes such as the hibernate with RTC mode which requires less than 18 $\mu$ A of current.

## 1.4 Functional Block Diagram

Figure 1-1 shows the functional block diagram of the TA3200R1D module.

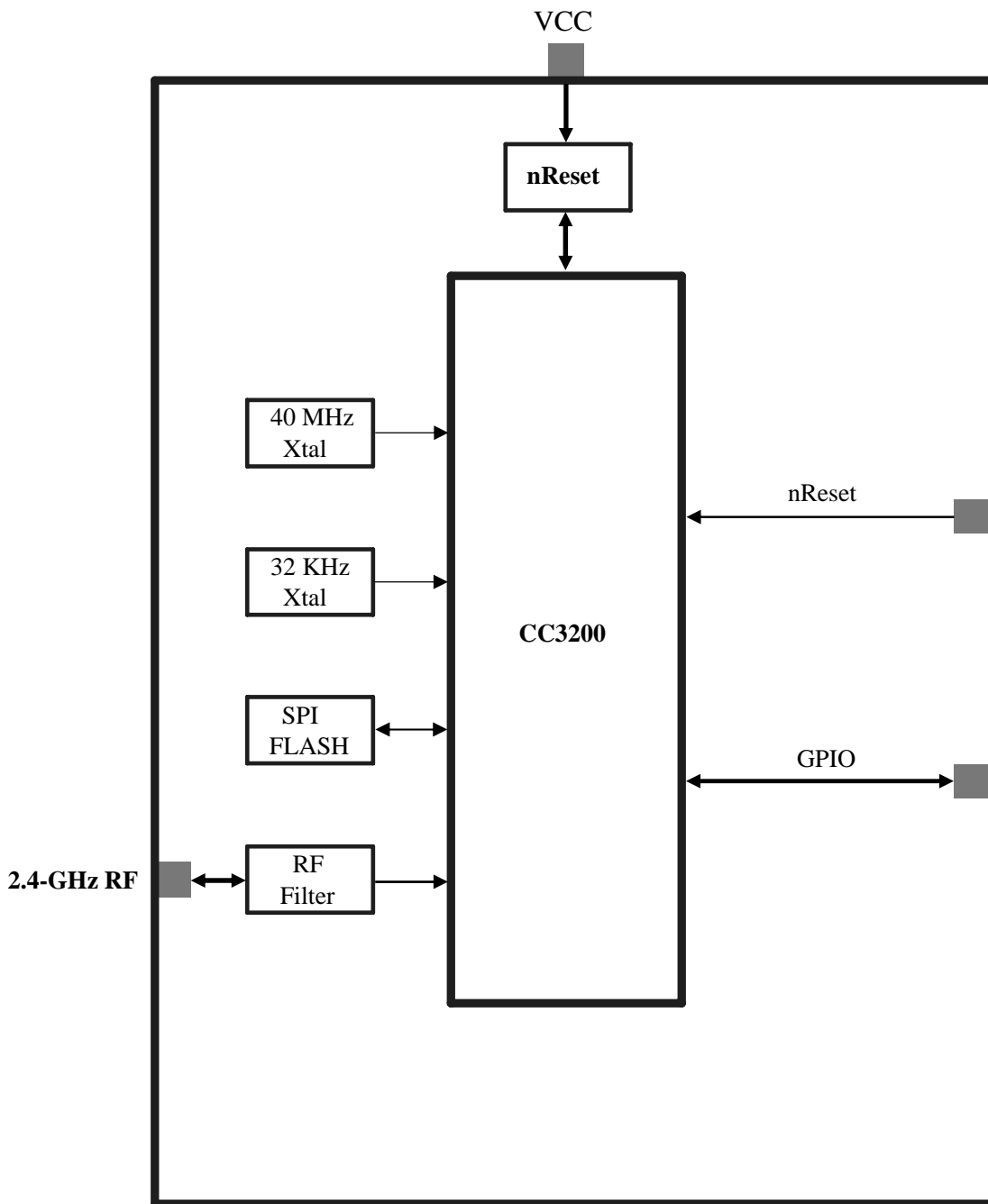

Figure 1-1. TA3200R1D Module Functional Block Diagram

## 2 TA3200R1D Terminal Overview

### 2.1 TA3200R1D Terminal Diagram

Figure 2-1 shows the Terminal diagram for the TA3200R1D

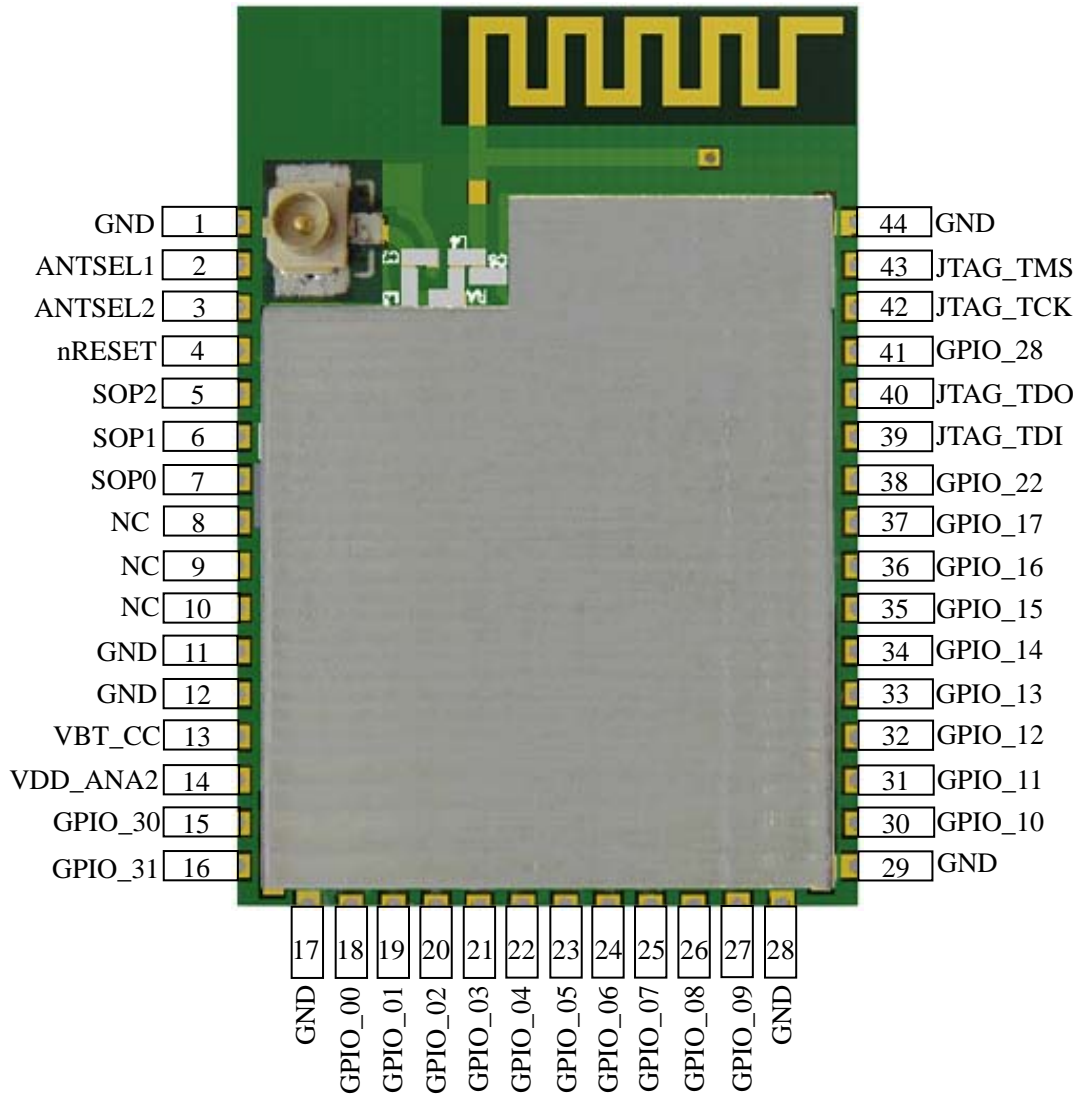

Figure 2-1. TA3200R1D Pin Diagram

## 2.2 TA3200R1D Terminal Descriptions

Table 2-1 lists the terminal descriptions of the TA3200R1D module.

Table 2-1. Terminal Descriptions

Pad Number	Pin Name	Description	CC3200 Pkg pin number
1	GND	Ground	65
2	ANTSEL1	Antenna Selection Control	29
3	ANTSEL2	Antenna Selection Control	30
4	nRESET	Master chip reset. Active low	32
5	SOP2	Sense On Power 2	21
6	SOP1	Sense On Power 1	34
7	SOP0	Sense On Power 0	35
8	NC		
9	NC		
10	NC		
11	GND	Ground	65
12	GND	Ground	65
13	VBT_CC	Chip Supply Voltage (VBAT)	10,37,39,44,54
14	VDD_ANA2	ANA2 DCDC O	47
15	GPIO_30	General-Purpose I/O	53
16	GPIO_31	General-Purpose I/O	45
17	GND	Ground	65
18	GPIO_00	General-Purpose I/O	50
19	GPIO_01	General-Purpose I/O	55
20	GPIO_02	General-Purpose I/O	57
21	GPIO_03	General-Purpose I/O	58
22	GPIO_04	General-Purpose I/O	59
23	GPIO_05	General-Purpose I/O	60
24	GPIO_06	General-Purpose I/O	61
25	GPIO_07	General-Purpose I/O	62
26	GPIO_08	General-Purpose I/O	63
27	GPIO_09	General-Purpose I/O	64
28	GND	Ground	65
29	GND	Ground	65
30	GPIO_10	General-Purpose I/O	1
31	GPIO_11	General-Purpose I/O	2
32	GPIO_12	General-Purpose I/O	3
33	GPIO_13	General-Purpose I/O	4
34	GPIO_14	General-Purpose I/O	5
35	GPIO_15	General-Purpose I/O	6
36	GPIO_16	General-Purpose I/O	7



Pad Number	Pin Name	Description	CC3200 Pkg pin number
37	GPIO_17	General-Purpose I/O	8
38	GPIO_22	General-Purpose I/O	15
39	JTAG_TDI	JTAG TDI. Reset Default Pinout.	16
40	JTAG_TDO	JTAG TDO. Reset Default Pinout	17
41	GPIO_28	General-Purpose I/O	18
42	JTAG_TCK	JTAG/SWD TCK Reset Default Pinout	19
43	JTAG_TMS	JTAG/SWD TMS Reset Default Pinout	20
44	GND	Ground	65

### 3 Specifications

#### 3.1 Absolute Maximum Ratings

These specifications indicate levels where permanent damage to the module can occur. Functional operation is not ensured under these conditions. Operation at absolute maximum conditions for extended periods can adversely affect long-term reliability of the module.

Symbol	Condition	Min	Typ	Max	Unit
VBAT and VIO	Respect to GND	-0.5	3.3	3.8	V
Digital I/O	Respect to GND	-0.5	-	VBAT+0.5	V
Operating temperature	-	-40	25	+85	°C

#### 3.2 Handling Ratings

		Min	Typ	Max	Unit
Storage Temperature	Tstg	-50	25	125	°C
Human Body Model	HBM	±1500			V
Machine Model	MM	±200			V

#### 3.3 Recommended Operating Conditions

Function operation is not ensured outside this limit, and operation outside this limit for extended periods can adversely affect long-term reliability of the module.

Symbol	Condition	Min	Typ	Max	Unit
VBAT and VIO	Battery mode	2.3	3.3	3.6	V

### 3.3.1 Reset Requirement

Parameter	Symbol	Min	Typ	Max	Unit
Operation mode level	ViH		0.65×VBAT		V
Shutdown mode level	ViL	0	0.6		V
Minimum time for nReset low for resetting the module		5			Ms
Rise/fall times	Tf/Tf		25		µs

### 3.3.2 Current Consumption

VBAT=3.6V

Mode	Parameters	Conditions	Min	Typ	Max	Unit
MCU ACTIVE	TX Current	1DSSS		278		mA
		6OFDM		254		
		54OFDM		229		
	RX Current	1DSSS		59		
		54OFDM		59		
MCU SLEEP	TX Current	1DSSS		275		mA
		6OFDM		251		
		54OFDM		226		
	RX Current	1DSSS		56		
		54OFDM		56		
MCU LPDS	TX Current	1DSSS		272		mA
		6OFDM		248		
		54OFDM		223		
	RX Current	1DSSS		53		
		54OFDM		53		
Peak calibration current		VBAT=3.3V		450		mA
		VBAT=2.3V		620		

## 4 Application Information

### 4.1 Reference Schematics

Figure 4-1 shows the reference schematic for the TA3200R1D module.

V<sub>CC</sub> Wide-Voltage Mode 2.3 to 3.6 V

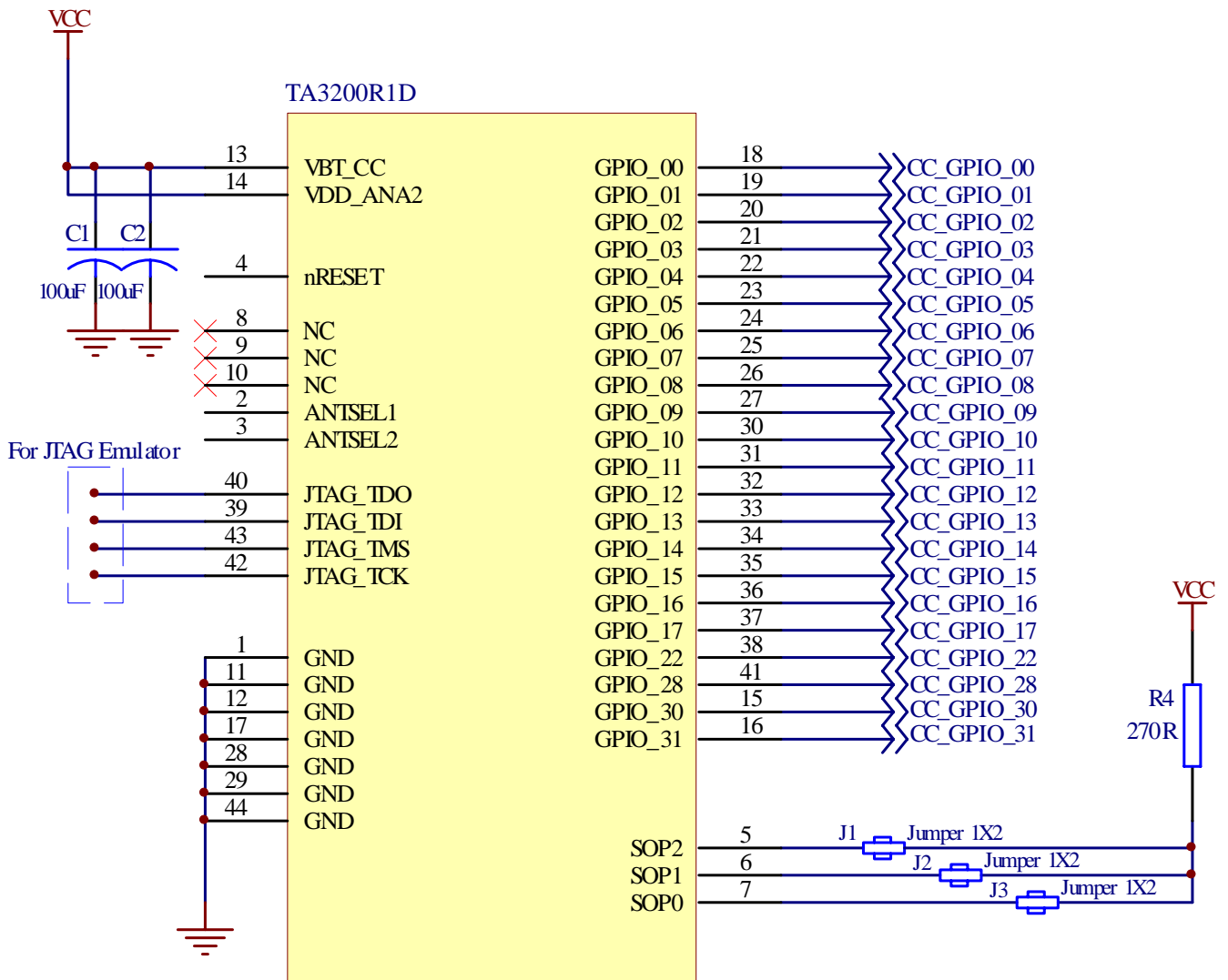

Figure 4-1. TA3200R1D Module Reference Schematic

Noted: Consider adding extra decoupling capacitors if the battery can not source the current. And please also make sure these two capacitors are closed to the port of VBT\_CC.

## 4.2 Antenna Style Selection

There are two antenna style for TA3200R1D Module

1. TA3200R1D-SA(PCB Strip Antenna)

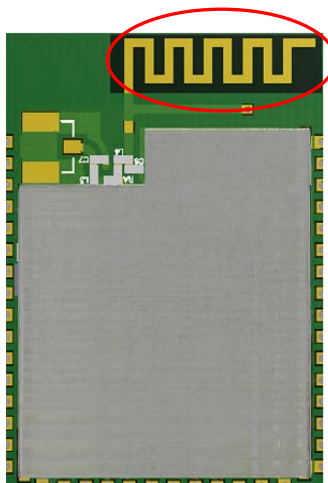

2. TA3200R1D-UFL(UFL Connector)

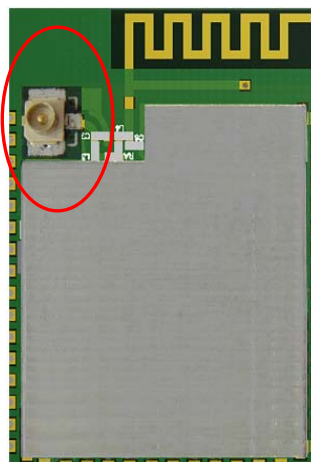

## 5 Mechanical Packaging

The following pages include mechanical packaging and orderable information. This information is the most current data available for the designated devices. This data is subject to change without notice and revision of this document. For browser-based versions of this data sheet, refer to the left-hand navigation.

### 5.1 Mechanical Drawing

Figure 5-1 shows the Mechanical of TA3200R1D module.

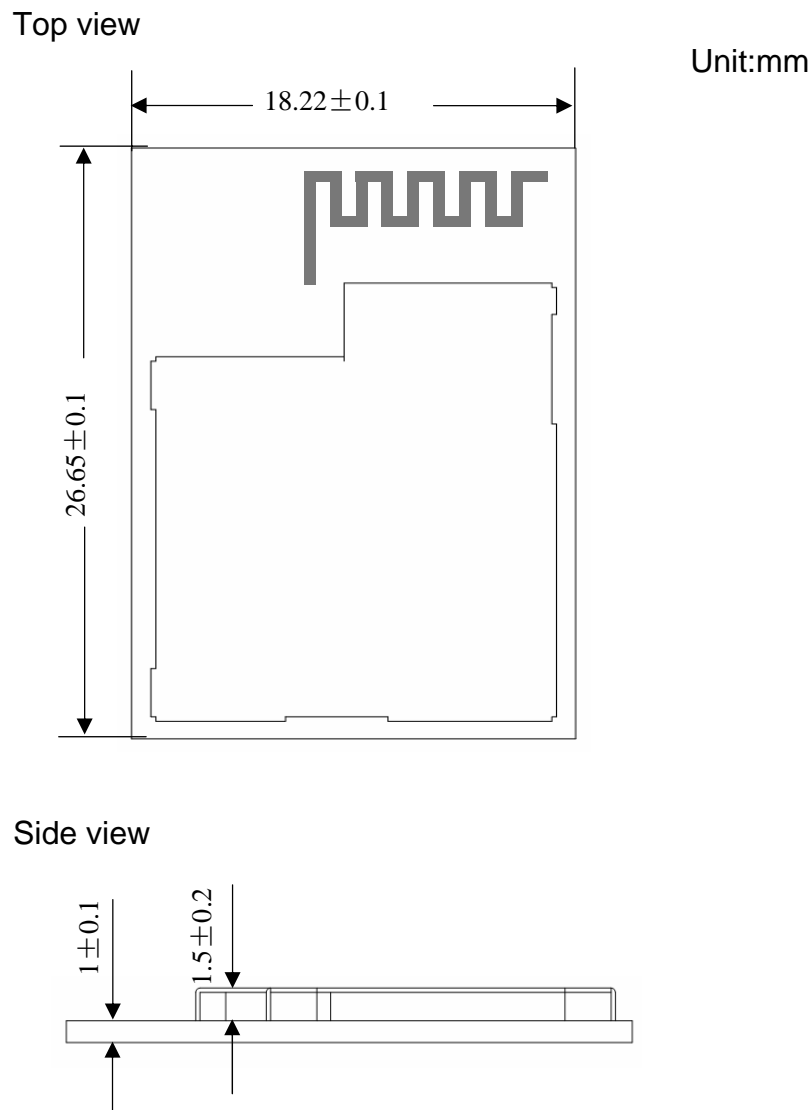

Figure 5-1. Mechanical Drawing

### 5.2 Recommended PCB Layout for Package

Figure 5-2 shows the Recommended PCB Layout of TA3200R1D module.

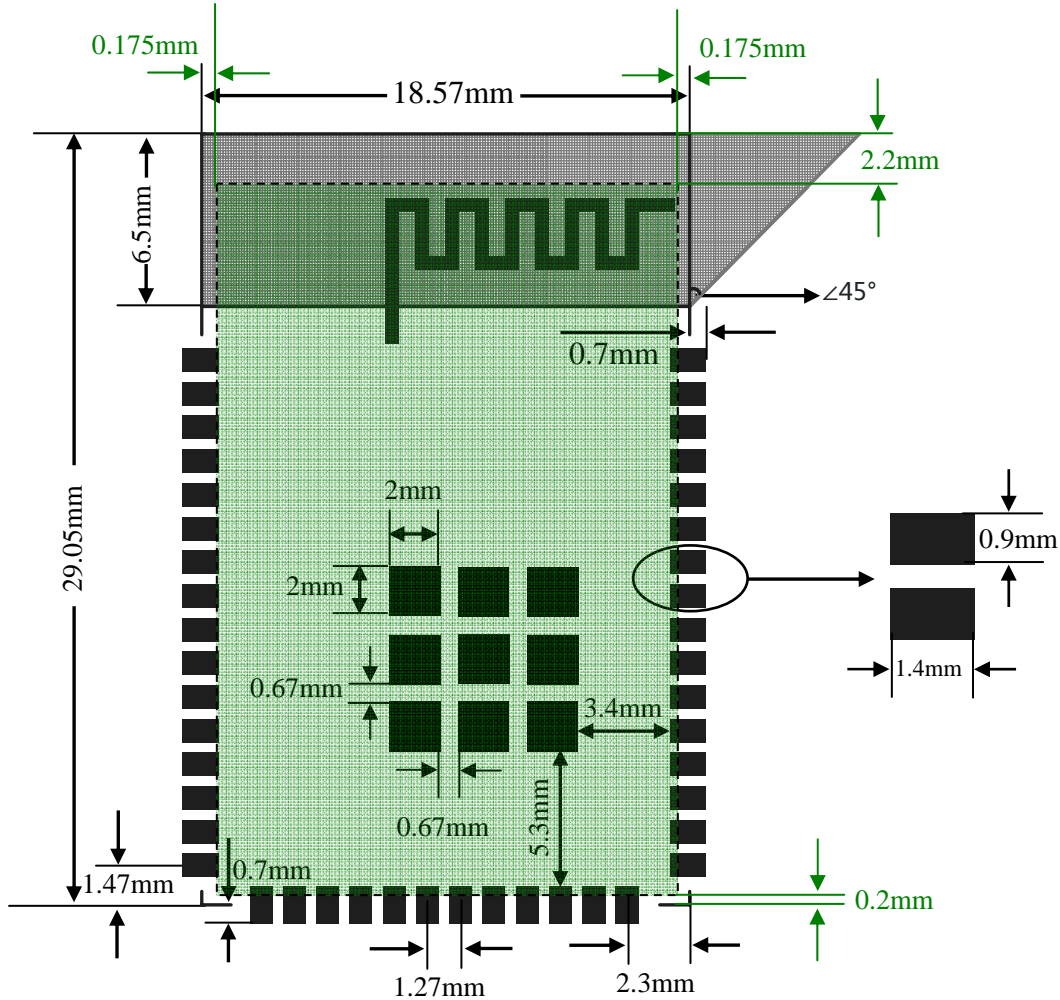

Figure 5-2 Recommended PCB Layout of TA3200R1D module shows the Mechanical of TA3200R1D module.

Noted: If using the PCB antenna please make sure the shadow area shall be without any wiring or ground.

The shade area of green is real size of the module.

## 6 Environmental Requirements and Specifications

### 6.1 Temperature

#### 6.1.1 PCB Bending

The PCB bending specification shall maintain planeness at a thickness of less than 0.1mm

### 6.2 Handling Environment

#### 6.2.1 ESD

The product ESD immunity is Human Body Model (HBM)  $\geq \pm 1500(V)$ , Mechanical Model(MM)  $\geq \pm 200(V)$ . Handle it under ESD protection environment.

This device is ESD sensitive, thus it must be protected at all times from ESD. Industry-standard ESD precautions must be followed at all time.

#### 6.2.2 Terminals

The product is mounted with motherboard through stamp hole. To prevent poor soldering, do not touch it by hand.

#### 6.2.3 Falling

The mounted components will be damaged if the product falls or is dropped. Such damage may cause the product malfunction.

### 6.3 Storage Condition

#### 6.3.1 Moisture Barrier Bag Before Opened

A moisture barrier bag must be stored in a temperature of less than 30°C with humidity under 85% RH. The calculated shelf life for the dry-packed product shall be a 12 months from the date the bag is sealed.

#### 6.3.2 Moisture Barrier Bag Open

Humidity indicator cards must be blue, <30%.

### 6.4 Baking Conditions

Products require baking before mounting if:

- Humidity indicator cards read >30%.
- Temp <30°C, humidity <70% RH, over 96 hours

Baking condition: 90°C, 12-24 hours

Baking times: 1 time

### 6.5 Soldering and Reflow Condition

1. Heating method: Conventional Convection or IR/convection
2. Temperature measurement: Thermocouple d=0.1mm to 0.2mm CA(K) or CC(T) at

- soldering portion or equivalent method.
3. Solder paste composition: Sn/3.0Ag/0.5Cu
  4. Allowable reflow soldering times: 2 times based on the following reflow soldering profile (see Figure 6-1).
  5. Temperature profile: Reflow soldering shall be done according to the following temperature profile (see Figure 6-1).
  6. Peak temp: 245°C.

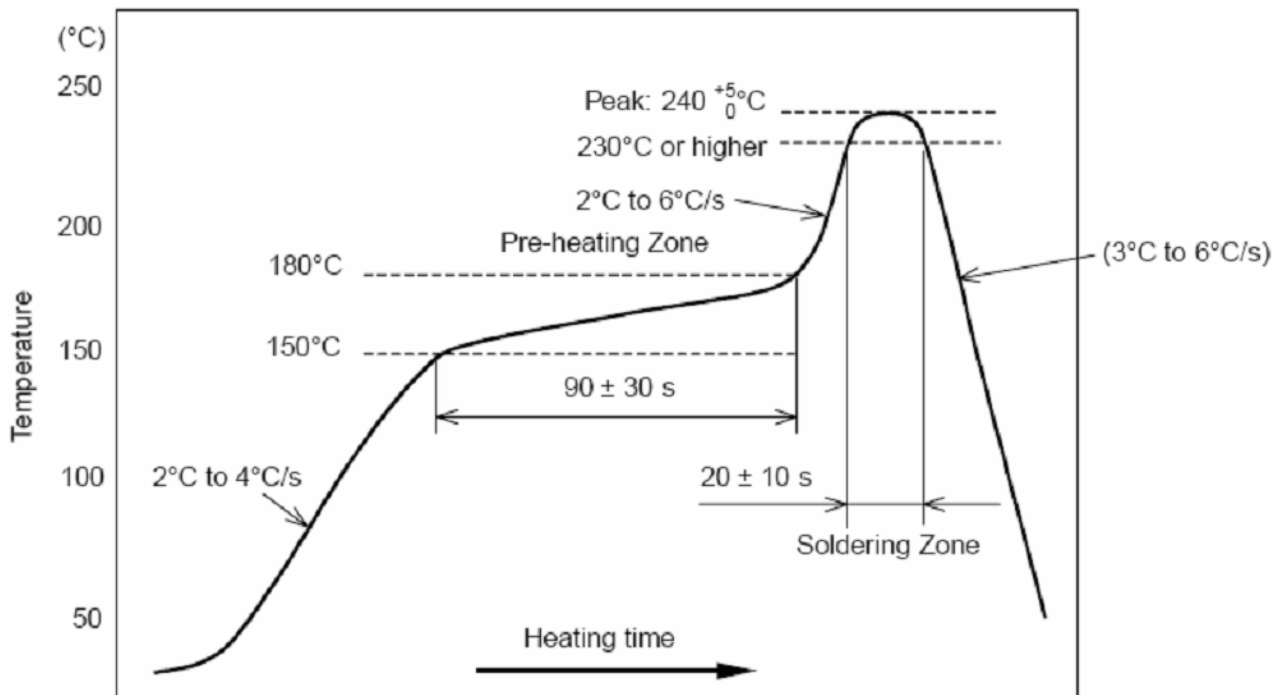

Figure 6-1. Temperature Profile for Evaluation of Solder Heat Resistance of a Component (at Solder Joint)

## Contact details

For more information, please send email to us.

Email:

[Sales@rf-products.com](mailto:Sales@rf-products.com)

[Helen@rf-products.com](mailto:Helen@rf-products.com)